

## Shear and Moment Capacity of the Ruytenschildt Bridge

Lantsoght, Eva; van der Veen, Cor; de Boer, A

**Publication date**

2016

**Document Version**

Accepted author manuscript

**Published in**

8th international conference on bridge maintenance, safety and management

**Citation (APA)**

Lantsoght, E., van der Veen, C., & de Boer, A. (2016). Shear and Moment Capacity of the Ruytenschildt Bridge. In *8th international conference on bridge maintenance, safety and management: Foz do Iguacu, Brazil* (pp. 1-8). University of Sao Paulo.

**Important note**

To cite this publication, please use the final published version (if applicable). Please check the document version above.

**Copyright**

Other than for strictly personal use, it is not permitted to download, forward or distribute the text or part of it, without the consent of the author(s) and/or copyright holder(s), unless the work is under an open content license such as Creative Commons.

**Takedown policy**

Please contact us and provide details if you believe this document breaches copyrights. We will remove access to the work immediately and investigate your claim.

# Shear and Moment Capacity of the Ruytenschildt Bridge

E.O.L. Lantsoght

*Concrete Structures, Delft University of Technology, Delft, The Netherlands*

*Politecnico, Universidad San Francisco de Quito, Quito, Ecuador*

C. van der Veen

*Concrete Structures, Delft University of Technology, Delft, The Netherlands*

A. de Boer

*Ministry of Infrastructure and the Environment, Rijkswaterstaat, Utrecht, The Netherlands*

**ABSTRACT:** In August 2014, the Ruytenschildt Bridge, a reinforced concrete solid slab bridge, in Friesland, the Netherlands was tested until failure. One of the goals of the experiment is to analyze the failure mode of the slab bridge under a tandem of 4 wheel loads and to compare the capacity of the full bridge structure to the predicted results, to have an idea of the residual strength of existing bridges. The methods used are experimental (testing of the bridge to failure in two of its five spans) and analytical. The analytical work involved predicting the bending moment capacity, the shear capacity and the punching capacity of the bridge. In both spans, the bridge failed in flexure. The total capacity during the experiment was significantly higher than predicted. The results indicate that the traditional rating procedures for shear are very conservative when applied to slab bridges that benefit from transverse load redistribution.

## 1 INTRODUCTION

In the decades following the Second World War, the Dutch road network was repaired and expanded. These actions included the construction of a large number of bridges. Of the current concrete bridges in the Dutch bridge stock, half of them were built before 1976. Many of these bridges are now reaching the end of their originally devised service life. Moreover, when these existing bridges are assessed with the current codes, often cross-sections that do not fulfill the code criteria for shear can be found. This lack of capacity is the result of the increase in traffic loads and volumes, reflected by the heavier live load models in NEN-EN 1991-2:2003 (CEN, 2003), combined with lower shear capacities according to the provisions from NEN-EN 1992-1-1:2005 (CEN, 2005) as compared to the Dutch codes that were used in the past, such as NEN 1009:1962 (Dutch Institute for Normalization, 1962) and NEN 3880:1974 (Dutch Institute for Normalization, 1974).

A subset of bridges that is under discussion are the reinforced concrete solid slab bridges. Even though a large number of these bridges were found to have insufficient shear capacity upon assessment, no signs of distress could be registered upon inspection (Walraven, 2010). This observation indicates that the real capacity of these structures is larger than the capacity that follows from the code provisions. In reality, additional bearing mechanisms as well as other effects, such as the increase in concrete com-

pressive strength due to the further hydration of the cement paste, result in a larger shear capacity than predicted. One of the bearing mechanisms that increases the shear capacity for reinforced concrete slabs is the ability of the slabs to distribute loads in the transverse direction (Lantsoght et al., (in press)).

To better understand the shear capacity of reinforced concrete slab bridges, research has been carried out in The Netherlands. This research comprised testing the shear capacity of reinforced concrete slabs (Lantsoght et al., 2013c, Lantsoght et al., 2014), improving methods for assessing slab bridges with a simple spreadsheet-based method (Vergoossen et al., 2013, Lantsoght et al., 2013b), based on linear finite element models (Lantsoght et al., 2013a) as well as based on non-linear finite element models (Rijkswaterstaat, 2012). Moreover, research is carried out to better understand how proof loading tests should be performed to rate bridges of which the capacity is under discussion because of material deterioration (for example, damage due to alkali-silica reaction) or because the support conditions changed the load bearing behavior (such as in the case of bridges with frozen bearings).

## 2 LITERATURE REVIEW

### 2.1 Proof loading

Two types of structural load tests can be carried out: diagnostic load tests and proof load tests. Diagnostic

load tests are typically done to verify the calculations of bridge structures. In some countries, such as Italy (Veneziano et al., 1984), Switzerland (Bruehwiler et al., 2012) and France (Cochet et al., 2004), a diagnostic load test is required before opening of the bridge. After a few decades, another diagnostic load test can be done to study the loss of stiffness due to material degradation. Proof load tests, on the other hand, involve higher loads. The goal of a proof load test is to verify the capacity of a bridge for a given load level.

In The Netherlands, research is carried out on proof loading of bridges, and pilot projects at the viaduct Vlijmen-Oost (Fennis et al., 2014), Halve maans Bridge (Fennis and Hordijk, 2014), viaduct in the Zijlweg (Koekkoek et al., 2015) and the Ruytenschildt Bridge (Lantsoght, 2014, Lantsoght, 2015) have been successfully executed. The test on the Ruytenschildt Bridge is used to link the load levels for proof loading to the ultimate load capacity. This paper, however, only focuses on the ultimate capacity of the Ruytenschildt Bridge.

## 2.2 Testing to failure of bridges

In the past, only a limited number of bridges have been tested to failure. An overview of those known by the authors is given in Table 1. It can be noted that the majority of these bridges were slab bridges, mostly resulting in a flexural failure.

The testing of the Thurloxtton underpass is not included (Cullington et al., 1996), because the test was carried out after applying saw cuts over 1 m, which does not give information about the behavior of the bridge as an entire structure.

Table 1. Overview of past testing to failure on bridges

Reference	Bridge name	Type of bridge	Failure mode
(Haritos et al., 2000)	Barr Creek	slab bridge	Flexural failure
(Azizinamini et al., 1994a, Azizinamini et al., 1994b)	Niobrara River	slab bridge	Flexural failure
(Miller et al., 1994, Aktan et al., 1992)	-	slab bridge	Punching failure
(Jorgenson and Larson, 1976)	ND-18	slab bridge	Flexural failure
(Bagge et al., 2015b, Bagge et al., 2015a)	Kiruna	prestressed girder bridge	Punching failure

## 2.3 Shear capacity of reinforced concrete slabs

The shear capacity of reinforced concrete slabs was studied extensively in the laboratory (Lantsoght et al., 2013c, Lantsoght et al., 2014, Lantsoght et al., 2015a). It was found that for slabs under concentrated loads close to supports, the shear capacity of slabs is larger than the shear capacity of beams, as a result

of the transverse load redistribution capacity of slabs (Lantsoght et al., (in press)).

However, the specimens that were used in the laboratory were half scale models of slab bridges and did not contain all the detailing and support conditions of a reinforced concrete slab bridge that has been in service for several decades. As such, the opportunity of testing the Ruytenschildt Bridge to failure was also very interesting for the study of the ultimate capacity of reinforced concrete slabs.

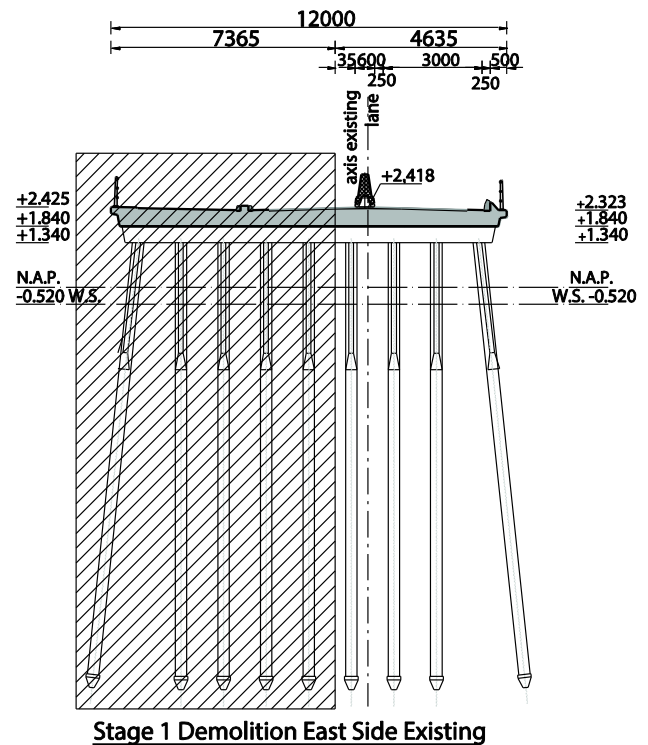

Figure 1. First stage of demolition of the Ruytenschildt Bridge. Shaded side is used for the experiment.

## 3 DESCRIPTION OF RUYTENSCHILDT BRIDGE

### 3.1 History and location

The Ruytenschildt Bridge, a reinforced concrete solid slab bridge, was built in 1962. The carriageway was divided into two lanes and a bike lane. The bridge is located in the province of Friesland (The Netherlands) in the national road N924 connecting the villages of Lemmer and Heerenveen, over a waterway connecting the Tjeuker Lake and the Vierhuister Course. The bridge was scheduled for demolition and replacement by a bridge at a larger height, allowing for the passage of taller boats. In August 2014, the Ruytenschildt Bridge in the Friesland province in the Netherlands was tested until failure. Staged demolition of the structure was used, so that one lane of motorized traffic could remain open. The cross-section showing the staged demolition is shown in Figure 1. The bike lane was deviated via a pontoon.

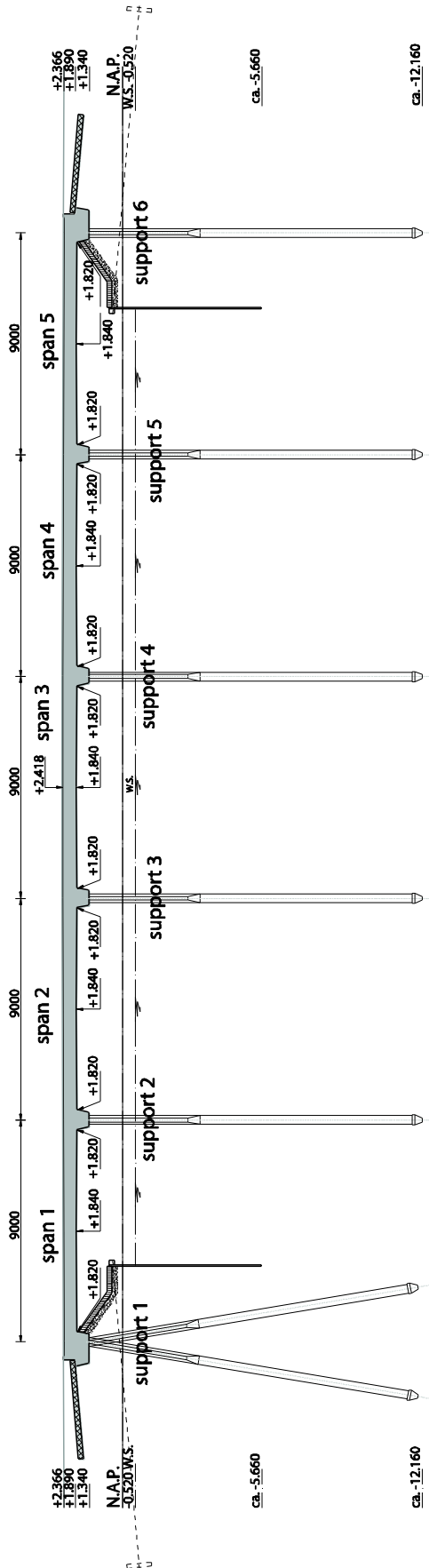

Figure 2. Side view of the Ruytschildt Bridge.

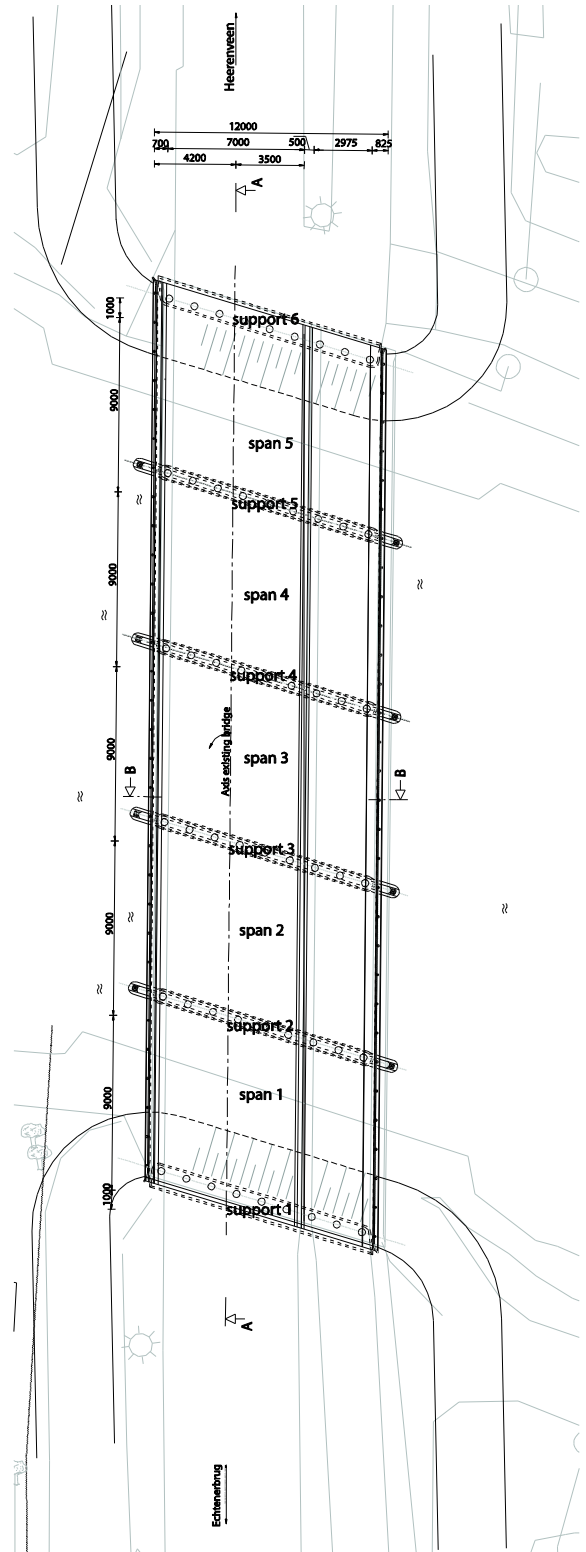

Figure 3. Top view of Ruytschildt Bridge

### 3.2 Geometry

The structure was a solid slab bridge with five spans. At the supports, cross-beams cast integrally onto the piers were used. The bridge had a skew angle of  $72^\circ$ . A side view is shown in Figure 2 and a top view in Figure 3.

In the first stage, 7.365 m of the bridge (see Fig. 1) was demolished and the remaining 4.365 m served as one traffic lane. A saw cut between both parts was made, and the eastern part of the bridge of 7.365 m wide was tested to failure in spans 1 and 2

(see Fig. 2 and Fig. 3). The slab thickness was about 550 mm.

### 3.3 Material properties

62 cores were drilled to test the concrete compressive strength, showing that the average cube compressive strength was  $f_{cm} = 40$  MPa with a characteristic value of  $f_{ck} = 25.4$  MPa (Lantsoght, 2015). After testing of the bridge, beams were sawn out of the untested spans for further research in the Stevin II Laboratory of Delft University of Technology. 31 concrete cores were drilled from the beam specimens in the lab (Yang, 2015). These additional tests provide a calibration factor for the poor surface treatment of the previously tested cores, resulting in  $f_{cm} = 63$  MPa, which corresponds to a cylinder compressive strength  $f_{cm,cyl} = 52$  MPa. On the cores, the thickness of the asphalt layer was measured as 51 mm.

Reinforcement steel QR24 was used, with a characteristic yield strength  $f_{yk} = 240$  MPa. Tensile tests on steel samples taken from the structure showed an average yield strength  $f_y = 352$  MPa and an average tensile strength  $f_t = 435$  MPa for the bars with a diameter  $\phi$  of 12 mm and  $f_y = 309$  MPa and  $f_t = 360$  MPa for  $\phi = 22$  mm. The samples were taken from the bridge after testing, so that yielding of the steel could have occurred before determining the material properties. Past testing of QR24 steel from a similar bridge gave  $f_y = 283$  MPa (Yang et al., 2010).

## 4 PREDICTION OF CAPACITY

### 4.1 Bending moment capacity

One of the goals of testing the Ruytenschildt bridge to failure, is to analyze the failure mode of the slab bridge under a tandem of 4 wheel loads and to compare the capacity of the full bridge structure to the predicted results, to have an idea of the residual strength of existing bridges. The analytical work involved predicting the bending moment capacity of the bridge as well as the beam shear and punching shear capacities. First, the bending moment capacity is treated. The moment at cracking,  $M_{cr}$ , at yielding,  $M_y$  and the ultimate moment  $M_u$  are determined based on a traditional beam analysis. The results are shown in Table 2.

Table 2. Bending moment capacity of span 1 and span 2 of the Ruytenschildt Bridge.

Flexural capacity	Span 1	Span 2, support	Span 2, span
$M_{cr}$ (kNm)	1816	1690	1592
$M_y$ (kNm)	3925	5662	3717
$M_u$ (kNm)	4964	7064	4705
Corresponding tandem load			
$P_{cr}$ (kN)	880	1278	1460
$P_y$ (kN)	2368	7720	3532
$P_u$ (kN)	3102	9940	4496

In Table 2, the total load on the tandem (both axes) to reach the computed moments in the cross-section is also determined, resulting in  $P_{cr}$  at cracking,  $P_y$  at yielding and  $P_u$  at the ultimate. It can immediately be seen from Table 2 that the flexural capacity in span 2 is determined by the span moment.

### 4.2 Shear capacity

To predict the capacity of the tested cross-sections, calculations were performed with average material parameters. The characteristic shear capacity from NEN-EN 1992-1-1:2005 §6.2.2. (CEN, 2005) can be converted into an average shear capacity by using  $f_{cm}$  and  $C_{Rm,c} = 0.15$  (Yang and den Uijl, 2011):

$$v_{R,c} = C_{Rm,c} k (100 \rho_l f_{cm})^{1/3} \quad (1)$$

For skewed slabs, the determination of the effective width in shear is ambiguous. Three options for the load spreading of a single axle have been studied:  $b_{str}$ , the effective width for a straight slab,  $b_{skew}$  with horizontal load spreading under  $45^\circ$  from the far side of the wheel print to the face of the support (Lantsoght et al., in press), and  $b_{para}$  based on a parallel load spreading to the straight case, as shown in Figure 4.

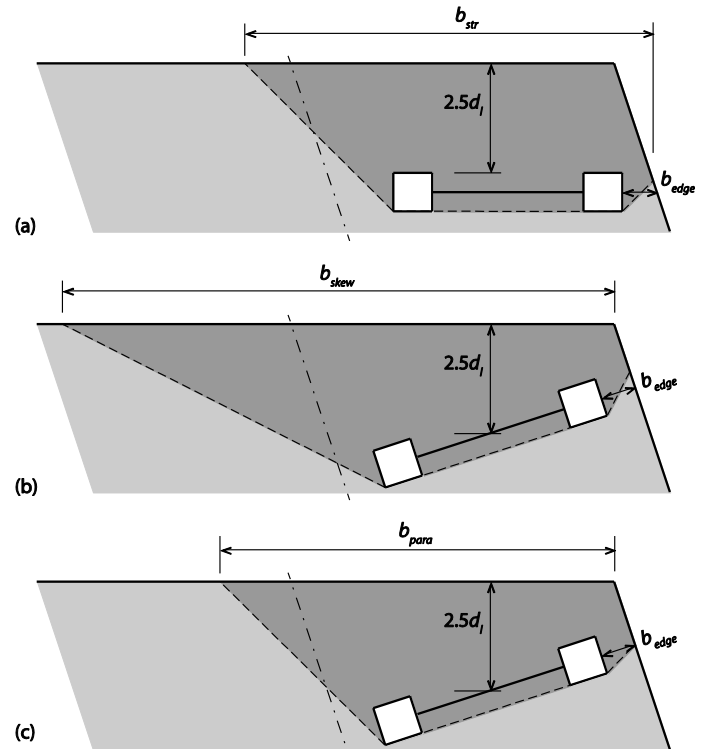

Figure 4. Possible ways to determine the effective width of a single axis in shear for a skewed slab: (a) assuming a straight slab; (b) using the traditional  $45^\circ$  load spreading method and (c) parallel to the straight case.

The maximum load on the tandem is sought so that the resulting shear stress at the support from all occurring loads equals the shear capacity from Eq. (1). The recommendations from the slab shear experiments are taken into account (Lantsoght et al.,



2013b). The maximum calculated tandem load (two axles) is given as  $P_{tot}$  in Table 3. From the slab shear experiments (Lantsoght et al., 2013c), the ratio of the tested to predicted (Eq. 1) shear capacity was found to be 2.023 (Lantsoght et al., 2015b), mainly caused by transverse load redistribution. Multiplying  $P_{tot}$  by 2.023 gives  $P_{tot,slab}$  in Table 3. This multiplication factor was derived in experiments on straight slabs. Skewed slabs, on the other hand, have larger stress concentrations in the obtuse corner, which could lead to smaller capacities (Cope et al., 1983). Therefore, the shear capacity is estimated in between  $P_{tot}$  and  $P_{tot,slab}$ .

Table 3. Shear capacity of span 1 and span 2 of Ruytenschildt Bridge for three different load spreading methods from Figure 4.

Span	Span 1		Span 2	
	Shear capacity	Shear capacity	Shear capacity	Shear capacity
	$P_{tot}$ (kN)	$P_{tot,slab}$ (kN)	$P_{tot}$ (kN)	$P_{tot,slab}$ (kN)
$b_{str}$	3760	7606	4020	8132
$b_{para}$	3236	6546	3432	6943
$b_{skew}$	4804	9718	5328	10779

### 4.3 Punching shear capacity

The previous analysis shows that a shear failure is possible in span 2: this observation can be made by comparing the maximum tandem loads in Table 2 and Table 3. Therefore, in span 2, the punching shear capacity is also determined (Lantsoght, 2014). This calculation showed that the stress at which punching failure occurs is more than 2.5 times larger than the shear stress at which one-way shear failure occurs. Therefore, for the given load configuration, punching shear is not a failure mode that is expected to occur.

### 4.4 Predicted failure modes

According to the analytical predictions, the first span fails in flexure and the second could fail in either shear or flexure. This prediction of the failure mode is based on taking the lowest value for the total load at which flexural failure or shear failure occurs as an indication. When taking into account experimental results from slabs tested in shear, it becomes clear that the second span fails in flexure as well.

## 5 DESCRIPTION OF EXPERIMENT

### 5.1 Test setup

The geometry of the tandem load of NEN-EN 1991-2:2003 (CEN, 2003) was used for the test, with wheel prints of 400 mm × 400 mm, a distance along the width between the wheels of 2 m and an axle distance of 1.2 m. The face-to-face distance between axle and cross-beam was  $2.5d_l$ , which is the critical position for shear failure (Rijkswaterstaat, 2013,

Lantsoght et al., 2013b). The distance between the saw cut line and the first wheel was 800 mm in span 1 and 600 mm in span 2. The tandem was placed in the obtuse angle, since this location is critical for shear (Cope, 1985).

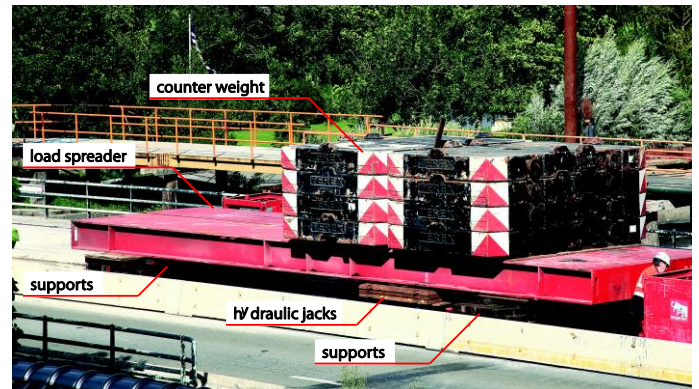

Figure 5. System with load spreader to apply loading.

For a safe execution of the experiment, a steel load spreader, see Figure 5, was applied over the span. Before the experiment, ballast blocks were placed on the load spreader, so that the slab was not yet loaded. During the experiment, the load was gradually transferred from the load spreader to the wheel prints in the deck by hydraulic jacks. If large deformations caused by failure would occur, the load on the jacks would decrease again thanks to this system.

During the proof loading and testing to failure of the Ruytenschildt bridge, the structure was instrumented to study the vertical and horizontal deformations, crack width, and to register cracking activities with acoustic emission measurements. The vertical deformations were measured with linear variable differential transformers (LVDTs) and laser triangulation sensors. The deformations on the bottom surface, indicating the average strain over 1 m, were measured by LVDTs. The opening of existing cracks was followed with LVDTs.

### 5.2 Experimental results

Several load cycles were applied, but only the last cycles of loading until the ultimate capacity are discussed here. The loading scheme for the final step for span 1 is given in Figure 6a, and for span 2 in Figure 6b.

The maximum load during the test on span 1 was 3049 kN, but failure was not achieved as the maximum load was determined by the maximum available counter weight. Flexural cracking was observed, indicating that the failure mode would have been a flexural failure. The maximum load corresponds with a sagging span moment of 4889 kNm.

For testing on span 2, additional load was ordered. The maximum load was 3991 kN, which corresponds to a hogging support moment of 3306 kNm and a sagging span moment of 4188 kNm. Flexural

failure was achieved. A settlement at the pier of 15 mm right after achieving the maximum load was observed. After removing all equipment, delayed recovery resulted in a residual settlement of 8 mm.

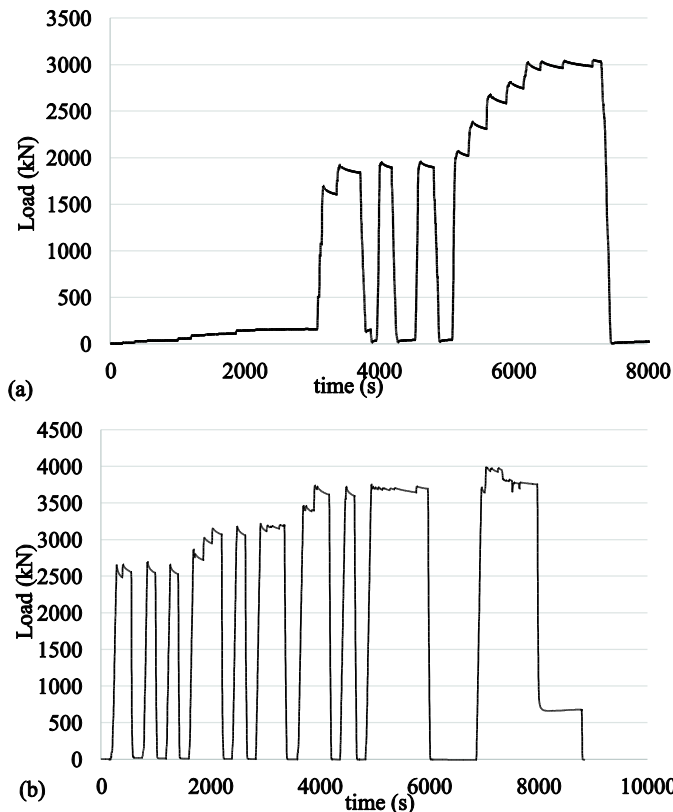

Figure 6. Loading scheme in final leg of experiment, testing to the ultimate capacity: (a) span 1; (b) span 2.

## 6 COMPARISON BETWEEN TEST AND PREDICTIONS

### 6.1 Span 1

The Ruytenschildt Bridge is an integral bridge, and therefore a moment develops at support 1. Because the rotational stiffness of support 1 is difficult to estimate, it was conservatively estimated as a hinge. During the experiment, a support moment develops which decreases the span moment, explaining why failure did not occur yet.

For span 1, the maximum experimental load was smaller than the predicted maximum for shear failure  $P_{tot}$ . If the slab effect is considered, then the maximum calculated load  $P_{tot,slab}$  is significantly higher than the experimental load.

### 6.2 Span 2

For span 2, the maximum sagging moment in the experiment lies in between  $M_y$  and  $M_u$ . This observation which corresponds with the experiment: span 2 failed by flexure in the span; yielding of the steel was observed but crushing of the concrete was not achieved.

With regard to the shear capacity, similar conclusions as for span 1 can be drawn. Moreover, since the slab failed in flexure, there is no indication of its ultimate shear capacity.

## 7 DISCUSSION

The results show that the loads applied during the test were higher than the conservatively estimated maximum capacity. However, these results indicate that the traditional rating procedures for shear are very conservative when applied to slab bridges that benefit from transverse load redistribution.

For the Ruytenschildt Bridge, tested to failure, the flexural capacity was as predicted for span 2, although in the end span the effect of the bridge being an integral bridge could be observed. For shear, the uncertainties with regard to the effect of the skew on the effective width result in difficulties predicting the shear capacity of the bridge. A range of values was given, from which it could be seen that the lower bound leads to conservative estimates. This lower bound is the shear capacity resulting from the Quick Scan method (Vergoossen et al., 2013, Lantsoght et al., 2013b), taking into account the recommendations from the slab shear tests. Therefore, it can be seen that the current rating procedures for shear are conservative. If further information about a certain bridge is necessary, a more refined analysis should be used.

To study the failure modes and their transition of slab bridges subjected to concentrated live loads, experiments on skewed slabs could give more information on the effective width and the transverse redistribution capacity of skewed slabs.

## 8 SUMMARY AND CONCLUSIONS

The ageing bridge stock in The Netherlands calls for a finer assessment of the existing structures, which requires more knowledge about the structural behavior, especially of reinforced concrete slab bridges. Therefore, an existing reinforced concrete solid slab bridge, the Ruytenschildt Bridge, scheduled for demolition, was tested to failure. Testing the Ruytenschildt Bridge was part of research on proof loading of bridges in the Netherlands as well as research on better understanding the ultimate capacity of reinforced concrete slab bridges. This paper dealt with the ultimate limit state only. Tests to failure of entire bridge structures are rare, as can be seen from the literature review on this topic, which identified five bridges that had been tested to failure in the past. The goal of testing the ultimate limit state of the Ruytenschildt Bridge was as well to see if there

could be a possible link to previous slab shear tests executed at Delft University of Technology.

The Ruytenschildt Bridge, consists of 5 spans, of which spans 1 and 2 were tested. The bending moment capacity was predicted based on a beam analysis. The shear capacity was more difficult to determine because of uncertainties in the analysis: the effective width of concentrated loads for skewed slabs is not determined, and the increase in shear capacity due to transverse load redistribution in skewed slabs is not defined either.

During the experiment, there was not enough load available to test span 1 to failure. In span 2, a flexural failure occurred combined with a large settlement of the pier.

Because the Ruytenschildt Bridge is an integral bridge, the span moment in the experiment was lower than found in the calculations assuming a hinged support. The stiffness and support moment are however not known and cannot be taken into account in the analysis. The failure in span 2, a flexural failure, corresponded well with the calculations: yielding of the steel was achieved in the cross-section but crushing of the concrete had not occurred yet.

## ACKNOWLEDGEMENTS

The authors wish to express their gratitude and sincere appreciation to the Province of Friesland and the Dutch Ministry of Infrastructure and the Environment (Rijkswaterstaat) for financing this research work. The contributions and help of our colleagues from Delft University of Technology A. Bosman, D.A. Hordijk, S. Fennis, P. van Hemert and Y. Yang, of the contractor de Boer en de Groot and of Mammoet, responsible for applying the load, are also gratefully acknowledged.

## REFERENCES

- AKTAN, A. E., ZWICK, M., MILLER, R. & SHAHROOZ, B. 1992. Nondestructive and Destructive Testing of Decommissioned Reinforced Concrete Slab Highway Bridge and Associated Analytical Studies. *Transportation Research Record: Journal of the Transportation Research Board*, 1371, 142-153.
- AZIZINAMINI, A., BOOTHBY, T. E., SHEKAR, Y. & BARNHILL, G. 1994a. Old Concrete Slab Bridges. 1. Experimental Investigation. *Journal of Structural Engineering-ASCE*, 120, 3284-3304.
- AZIZINAMINI, A., SHEKAR, Y., BOOTHBY, T. E. & BARNHILL, G. 1994b. Old Concrete Slab Bridges. 2. Analysis. *Journal of Structural Engineering-ASCE*, 120, 3305-3319.
- BAGGE, N., SAS, G., NILIMAA, J., BLANKSVARD, T., ELFGREN, L., TU, Y. & CAROLIN, A. 2015a. Loading to failure of a 55 year old prestressed concrete bridge. *IABSE Workshop*. Helsinki, Finland.
- BAGGE, N., SHU, J., PLOS, M. & ELFGREN, L. 2015b. Punching Capacity of a Reinforced Concrete Bridge Deck Slab Loaded to Failure. *IABSE 2015*.
- BRUEHWILER, E., VOGEL, T., LANG, T. & LUECHINGER, P. 2012. Swiss Standards for Existing Structures. *Structural Engineering International*, 22, 275-280.
- CEN 2003. Eurocode 1: Actions on structures - Part 2: Traffic loads on bridges, NEN-EN 1991-2:2003. Brussels, Belgium: Comité Européen de Normalisation.
- CEN 2005. Eurocode 2: Design of Concrete Structures - Part 1-1 General Rules and Rules for Buildings. NEN-EN 1992-1-1:2005. Brussels, Belgium: Comité Européen de Normalisation.
- COCHET, D., CORFDIR, P., DELFOSSE, G., JAFFRE, Y., KRETZ, T., LACOSTE, G., LEFAUCHEUR, D., KHAC, V. L. & PRAT, M. 2004. Load testing of roadway and pedestrian bridges. Bagnex-Cedex, France: Setra - Service d'Etudes techniques des routes et autoroutes. (in French)
- COPE, R. J. 1985. Flexural Shear Failure of Reinforced-Concrete Slab Bridges. *Proceedings of the Institution of Civil Engineers Part 2-Research and Theory*, 79, 559-583.
- COPE, R. J., RAO, P. V. & EDWARDS, K. R. 1983. Shear in skew reinforced concrete slab bridges - analytical and experimental studies - A report to the Department of Transport. Liverpool, UK: University of Liverpool.
- CULLINGTON, D. W., DALY, A. F. & HILL, M. E. 1996. Assessment of reinforced concrete bridges: Collapse tests on Thurloxton underpass. *Bridge Management*, 3, 667-674.
- DUTCH INSTITUTE FOR NORMALIZATION 1962. NEN 1009:1962 Provisions Reinforced Concrete. (in Dutch)
- DUTCH INSTITUTE FOR NORMALIZATION 1974. NEN 3880:1974 Provisions Concrete. (in Dutch)
- FENNIS, S., HEMERT, P. V., HORDIJK, D. & BOER, A. D. 2014. Proof loading viaduct Vlijmen-Oost. *Cement*, 5, 40-45. (in Dutch)
- FENNIS, S. A. A. M. & HORDIJK, D. A. 2014. Proof loading Halvemaans Bridge Alkmaar. Stevin Report 25.5-14-05, Delft, The Netherlands: Delft University of Technology. (in Dutch)
- HARITOS, N., HIRA, A., MENDIS, P., HEYWOOD, R. & GIUFRE, A. 2000. Load testing to collapse limit state of Barr Creek Bridge. *Transportation Research Record*, A92-A102.
- JORGENSON, J. L. & LARSON, W. 1976. Field Testing of a Reinforced Concrete Highway Bridge to Collapse. *Transportation Research Record: Journal of the Transportation Research Board*, 607, 66-71.
- KOEKKOEK, R. T., LANTSOGHT, E. O. L. & HORDIJK, D. A. 2015. Proof loading of the viaduct in the Zijlweg. Stevin Report nr. 25.5-15-08, Delft, The Netherlands: Delft University of Technology.
- LANTSOGHT, E., VEEN, C. V. D., BOER, A. D. & WALRAVEN, J. (in press). Transverse Load Redistribution and Effective Shear Width in Reinforced Concrete Slabs. *Heron*, 29 pp.
- LANTSOGHT, E. O. L. 2014. Ruytenschildt Bridge: Preparation of testing to failure of span of slab bridge. Stevin Report 25.5-14-03. Delft, The Netherlands: Delft University of Technology. (in Dutch)
- LANTSOGHT, E. O. L. 2015. Ruytenschildt Bridge: Analysis experimental results in the ultimate limit state. Stevin Report Nr. 25.5-15-05, Delft, The Netherlands: Delft University of Technology. (in Dutch)
- LANTSOGHT, E. O. L., DE BOER, A., VAN DER VEEN, C. & WALRAVEN, J. C. 2013a. Peak shear stress distribution in finite element models of concrete slabs. In: ZINGONI, A. (ed.) *Research and Applications in Structural*



- Engineering, Mechanics and Computation*. Cape Town, South Africa: Taylor and Francis.
- LANTSOGHT, E. O. L., DE BOER, A., VAN DER VEEN, C. & WALRAVEN, J. C. in press. Effective Shear Width of Concrete Slab Bridges *Institute of Civil Engineers – Bridge Engineering*.
- LANTSOGHT, E. O. L., VAN DER VEEN, C., DE BOER, A. & WALRAVEN, J. 2014. Influence of Width on Shear Capacity of Reinforced Concrete Members. *ACI Structural Journal*, 111, 1441-1450.
- LANTSOGHT, E. O. L., VAN DER VEEN, C., DE BOER, A. & WALRAVEN, J. 2015a. One-way slabs subjected to combination of loads failing in shear. *ACI Structural Journal*, 112, 417-426.
- LANTSOGHT, E. O. L., VAN DER VEEN, C., DE BOER, A. & WALRAVEN, J. C. 2013b. Recommendations for the Shear Assessment of Reinforced Concrete Slab Bridges from Experiments. *Structural Engineering International*, 23, 418-426.
- LANTSOGHT, E. O. L., VAN DER VEEN, C., DE BOER, A. & WALRAVEN, J. C. 2015b. Proposal for the extension of the Eurocode shear formula for one-way slabs under concentrated loads. *Engineering Structures*, 95, 16-24.
- LANTSOGHT, E. O. L., VAN DER VEEN, C. & WALRAVEN, J. C. 2013c. Shear in One-way Slabs under a Concentrated Load close to the Support. *ACI Structural Journal*, 110, 275-284.
- MILLER, R. A., AKTAN, A. E. & SHAHROOZ, B. M. 1994. Destructive testing of decommissioned concrete slab bridge. *Journal of Structural Engineering-ASCE*, 120, 2176-2198.
- RIJKSWATERSTAAT 2012. Guidelines for Nonlinear Finite Element Analysis - Scope: Girder members.
- RIJKSWATERSTAAT 2013. Guidelines Assessment Existing Bridges - assessment of structural safety of an existing bridge at the level of renovation, usage and disapproval. (in Dutch)
- VENEZIANO, D., GALEOTA, D. & GIAMMATTEO, M. M. 1984. Analysis of bridge proof-load data I: Model and statistical procedures. *Structural Safety*, 2, 91-104.
- VERGOOSSEN, R., NAAKTGEBOREN, M., 'T HART, M., DE BOER, A. & VAN VUGT, E. 2013. Quick Scan on Shear in Existing Slab Type Viaducts. *International IABSE Conference, Assessment, Upgrading and Refurbishment of Infrastructures*. Rotterdam.
- WALRAVEN, J. C. 2010. Residual shear bearing capacity of existing bridges. *fib Bulletin 57, Shear and punching shear in RC and FRC elements; Proceedings of a workshop held on 15-16 October 2010*. Salò, Lake Garda, Italy.
- YANG, Y. 2015. Experimental Studies on the Structural Behaviours of Beams from Ruytenschildt Bridge. Stevin Report 25.5-15-09. Delft: Delft University of Technology.
- YANG, Y. & DEN UIJL, J. A. 2011. Report of Experimental Research on Shear Capacity of Beams Close to Intermediate Supports. Stevin Report Nr. 25.5-11-10. Delft: Delft University of Technology.
- YANG, Y., DEN UIJL, J. A., DIETEREN, G. & DE BOER, A. 2010. Shear capacity of 50 years old reinforced concrete bridge deck without shear reinforcement. *3rd fib International Congress*. Washington DC, USA: fib.