

A study of the dynamic effects on the design loads of a civil aircraft

Bronstein, M; Feldman, E; Vescovini, R; Bisagni, Chiara

Publication date

2016

Document Version

Accepted author manuscript

Published in

Proceedings of 56th Israel Annual Conference on Aerospace Sciences

Citation (APA)

Bronstein, M., Feldman, E., Vescovini, R., & Bisagni, C. (2016). A study of the dynamic effects on the design loads of a civil aircraft. In Proceedings of 56th Israel Annual Conference on Aerospace Sciences: Tel-Aviv & Haifa, Israel

Important note

To cite this publication, please use the final published version (if applicable).
Please check the document version above.

Copyright

Other than for strictly personal use, it is not permitted to download, forward or distribute the text or part of it, without the consent of the author(s) and/or copyright holder(s), unless the work is under an open content license such as Creative Commons.

Takedown policy

Please contact us and provide details if you believe this document breaches copyrights.
We will remove access to the work immediately and investigate your claim.

A study of the dynamic effects on the design loads of a civil aircraft

Michael Bronstein^{1,a}, Esther Feldman^a, Riccardo Vescovini^b and Chiara Bisagni^b

^aIsrael Aircraft Industries, Tel Aviv, Israel

^bPolitecnico di Milano, Department of Aerospace Science and Technology, Milano, Italy

Acknowledgements

The DAEDALOS project was supported by the European Commission under the Programme TRANSPORT (including AERONAUTICS) of the 7th Framework Programme for Research and Technological Development, Grant agreement no: 266411.

DAEDALOS stands for **DYNAMICS IN AIRCRAFT ENGINEERING DESIGN AND ANALYSIS FOR LIGHT OPTIMIZED STRUCTURES**

The primary objective of the DAEDALOS project is to investigate the dynamic effects on the actual loads acting on the airframe for improved definition of the sizing loads for structural components of civil aircrafts.

Abstract

This paper addresses the effects of a fully dynamic approach to determine the design loads of a mid-size business jet. The study is conducted by considering the fuselage midsection of the DAEDALOS aircraft model with landing impact conditions. This study aims to compare the loads levels obtained with the quasi-static approach usually used in the aircraft design process with a novel full dynamic method of analysis.

The comparison is presented in terms of stress levels between the novel dynamic approach and the standard design practice based on the use of equivalent static loads. The results illustrate that a slight reduction of the load levels can be achieved, but a careful modelling of the damping level is needed. Guidelines for an improved load definition are discussed, and suggestions for future research activities are provided.

1. Introduction

The DAEDALOS project has the aim to develop new methods to reduce the uncertainty and the conservatism of today's design and certification procedures. Among the objectives of the project, an in-depth investigation was carried out to research the dynamic effects in the context of the design loads definition. The present study focuses on dynamic landing, a loading condition usually relevant for the fuselage design.

Despite the improvements due to modern simulation techniques, common design practice still relies on the use of equivalent-static approach to establish the stress distribution in response to dynamic loading conditions, such as those due to a landing impact.

The main advantage of the standard design practice is its simplicity and time effectiveness. Indeed, the evaluation of the aircraft internal forces and the subsequent evaluation of the stress distribution can be

performed by direct application of a predefined set of static loads on the finite element model of the structure. However, the procedure suffers from its inability to account for the propagation along the fuselage of the loading forces - mainly related to the frequency content of the input load and the characteristic frequencies of the fuselage structure - and damping, i.e. the capability of the structure itself to damp the loading waves amplitudes, starting from the zone close to the load introduction point and propagating away from it.

In particular, the method assumes that the model does not absorb any energy by the stringer/frame/skin interfaces and the load acting at a certain location is propagated along the fuselage without attenuation arising from structural damping.

These dynamic effects could influence the final design, and have an impact on the final weight of the configuration.

An improved fully dynamic approach could be adopted if more refined finite element models are used in the early phases of the design process. In this case, the transient dynamic analysis is performed directly using a shell model, with no need to transfer the relevant loads from the stick to the shell model in the form of static loads. In this context, the structural response, which can be performed in the time or in the frequency domain, is determined for different loading conditions by adopting finite element models with a larger number of degrees of freedom. Using these models, the stress distribution of the various portions of the structure can be directly monitored at the various timeframes of the load history. The increase of the overall analysis time is noticeable and, for this reason, classical design procedures have usually discarded a fully dynamic design procedure.

The goal of the present work is to assess the possible advantages due to the adoption of a dynamic approach in the sizing process of a typical business jet. The benefits due to a dynamic design strategy are investigated with regard to the structural weight. Part of the study is directed towards the evaluation of the effects due to the damping properties on the reduction of the design loads.

A more comprehensive description of this study is presented in the paper of Ref. 4.

2. Aircraft Model Description

The aircraft model here considered was developed within the DAEDALOS project on the basis of the experience of the industrial partners involved in the project. The aircraft configuration is considered as representative of a mid-size business jet, powered by two turbofan engines mounted in the aft fuselage. A sketch of the model and its relevant dimensions are provided in Figure 1.

2.1 Structural Section

A section of the mid fuselage was used as the study area in this investigation. This portion of structure is the one experiencing the highest load levels in response to the fuselage bending after an impact loading. A sketch of the portion of structure is shown in Figure 2.

This section extends from a distance of 5582 mm from the fuselage nose, up to 9905 mm. The overall length of the barrel here considered is then 4323 mm.

The comparison between the standard procedure and the improved one is conducted by comparison of the stress levels in terms of components σ_y , where y denotes the direction along the fuselage axis. To this aim, the stress level is monitored for all the elements of the selected section.

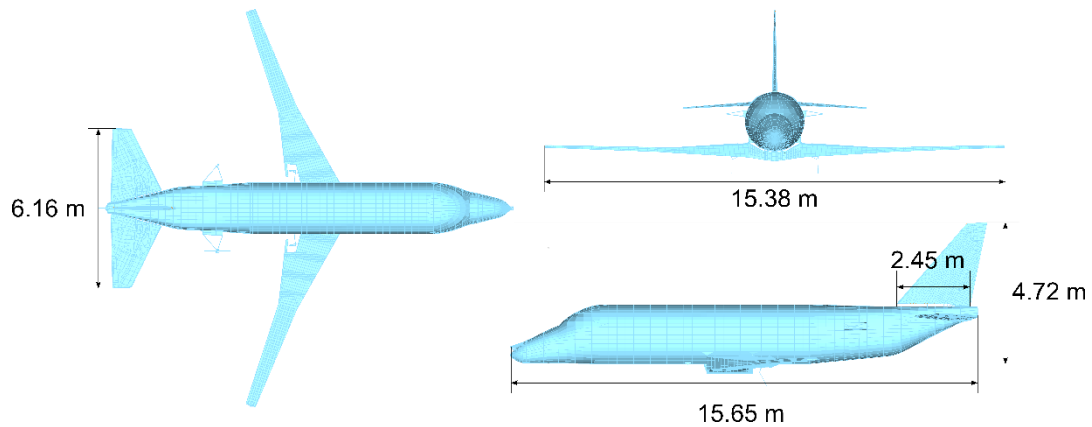

Figure 1. DAEDALOS aircraft model.

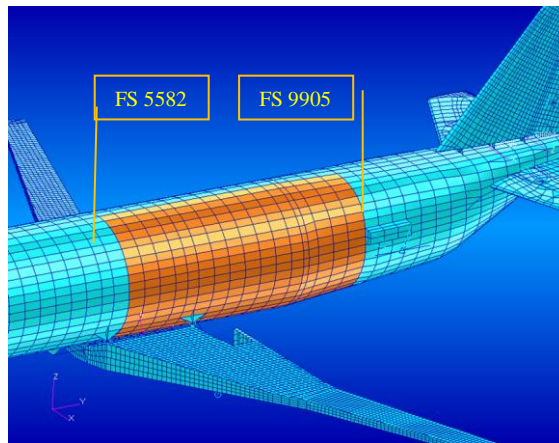

Figure 2. Fuselage section selected for the study.

2.2 Landing Gear

The stress distribution due to a landing impact is influenced by the load introduction in correspondence of the landing gear attachment. The DAEDALOS aircraft model is characterized by a trailing link landing gear, with the presence of an energy absorbing element (shock absorber) mounted between the rigid upper trunnion part and a moving element or trailing link. A sketch of the landing gear is shown in Figure 3(a).

The shock absorber is assumed to be of the oleo-pneumatic type.

Regarding the mathematical model of the landing gear, the shock absorber is approximated as a spring to represent the isotropic curve of the compressed gas, and a damping element to account for the damping effect of the oil. The tire is also represented by its stiffness and damping coefficient. The fore-aft stiffness of the landing gear is represented separately by a specific stiffness element. A sketch of the landing gear model is presented in Figure 3(b).

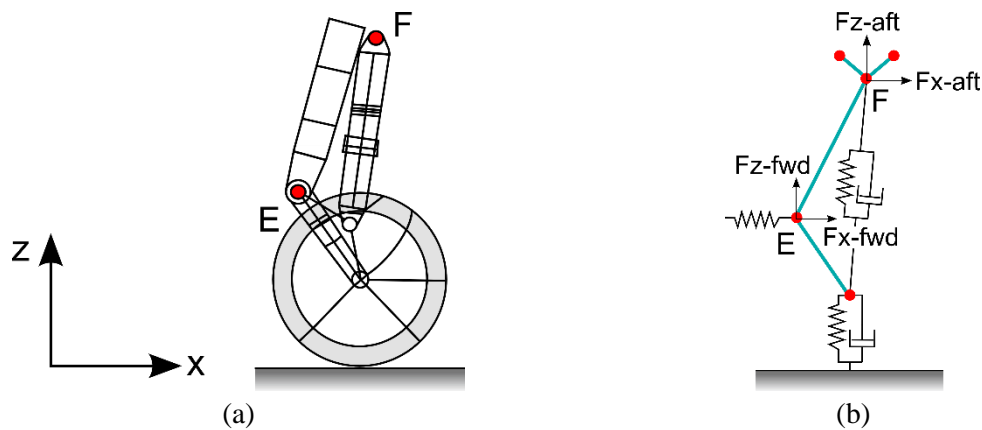

Figure 3. Main landing gear: (a) configuration, (b) mathematical representation.

3. Loading Conditions

Typical design conditions of the fuselage section are those corresponding to the landing impact of the aircraft. These conditions, usually referred to as “dynamic landing”, are analyzed referring to the requirements of FAR/CS 25.473, 25.479, 25.481, 25.483, 25.485 [Refs 1 and 2].

More specifically, the aircraft is assumed to impact the ground with a vertical velocity equal to 10 fps at level and tail down attitudes with a maximum gross weight up to the design of Maximum Landing Weight (MLW).

For the current study, two weight configurations (BOW – Basic Operating Weight, MLW – Max. Landing Weight) were used for the analysis of the loads due to landing:

Furthermore, each of the two configurations were analyzed by considering four distinct landing conditions:

- Tail Down with Sea level conditions (TD_VL1)
- Tail Down with Hot and high conditions (TD_VL2)
- Level Landing with Sea level conditions (LL_VL1)
- Level Landing with Hot and high conditions (LL_VL2)

For all the loading conditions, the internal loads are evaluated at different fuselage sections. The critical condition was identified as the Tail Down with hot and high conditions (TD_VL2) for the MLW configuration.

Both for the static and the dynamic approach, the net loads on the airframe due to the landing impact on the main landing gear are determined by the superposition of the 1g static loads acting on the aircraft just before touchdown, landing gear reactions, and dynamic loads of the aircraft structure.

The simulations of landing impact are based on the mathematical model of the landing gear described in Section 2.2, which in turn is attached to the flexible airframe.

The model is implemented by an in-house code developed by IAI Loads & Dynamics Group and combined with data obtained from MSC NASTRAN [10]. This code solves the equation of motion of the aircraft and landing gear during the landing impact.

Landing gear reactions are calculated at the interface points in the landing gear (points E and F, Figure 3) and are introduced through these points into the flexible aircraft model.

For each landing condition, the landing gear forces time histories are calculated and combined with the dynamic response of the flexible airframe

As discussed in the next section, in the standard design approach the landing gear is connected to the stick model, while in the dynamic approach it is connected to the full shell model.

4. Overview of the Methodologies

The static and the dynamic approaches have been applied to simulate the sizing process of a specific section of the fuselage and to establish, by comparison, any potential weight reduction. In the present investigation the stresses directed along the fuselage axial direction are taken as design parameters. The analyses are performed with the commercial code MSC NASTRAN, and two kinds of finite element models, denoted hereinafter the stick and the 3D shell models, are adopted. Both models are shown in Figure 4.

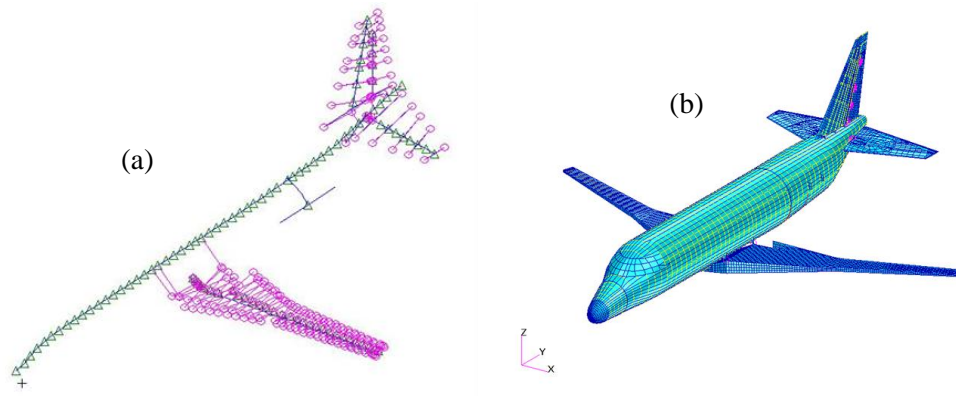

Figure 4. Finite element models: (a) stick model (b) 3D shell model

Due to the symmetry of the loading conditions, the models are reduced to half of the overall structure by imposing symmetry constraints at the intersection between the structure and the symmetry plane. The stick model, presented in Figure 4(a), is composed of 107 bar and 20 beam elements, respectively. Rigid elements and concentrated masses are introduced to achieve a good description of the dynamic properties of the aircraft.

The shell finite element model is reported in Figure 4(b). It is characterized by a relatively coarse mesh, with a number of 29965 shell elements, 17420 rods and 995 bars.

An overview of the static and the dynamic procedure is provided in Figure 5.

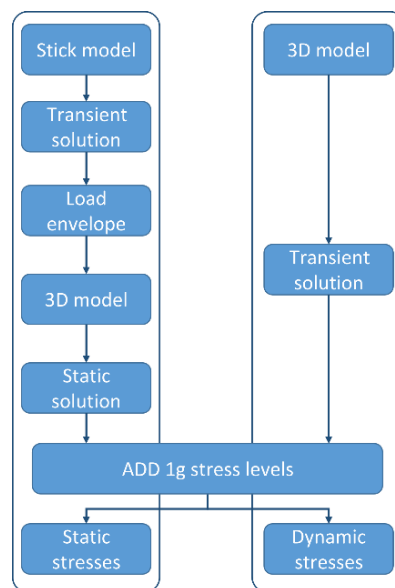

Figure 5. Overview of the standard approach and of the fully dynamic approach.

The static approach is summarized in the left part of the chart. In this case, the main landing gear reactions are applied to the stick model and a dynamic analysis is performed. Then, the design conditions are identified at each fuselage section on the basis of the internal force distribution as obtained from the stick model. Finally, the force distributions derived from the stick model are transferred to the 3D shell model in the form of equivalent static loads. A linear static analysis is then performed and the stress distribution for the structural sizing is established.

The workflow of the dynamic approach is illustrated in the right part of Figure 5. In this case, the landing gear reactions are applied directly on the 3D shell model, which is analyzed by performing a direct transient analysis. As result, time histories are available for each element of the model, and the sizing stresses are taken as the maximum values during the timeframe considered.

5. Standard Approach Based on Equivalent Static Loads

The static loading approach relies on the adoption of a simplified finite element model of the aircraft, the stick model, which is used to determine the dynamic characteristics of the aircraft.

Standard design procedures based on static loadings make use of stick models derived from a full, detailed, FE model adopted for stress analyses. Furthermore, these models are generally updated and tuned on the basis of the results, if available, from ground vibration testing.

A set of load cases is then assembled based on the number of critical time points obtained from the dynamic analysis and by combining the 1g static loads with the incremental dynamic loads due to the landing impact. Maximum and minimum integral loads are obtained for each fuselage section and the corresponding load cases are selected as critical.

Each of the selected critical load cases is representative of a single time point taken from the whole time response, and is then expressed as a balanced static force distribution over the grids of the loads model. The load distribution is transferred, as a set of equivalent static forces, on the grids of the full FE model.

Once the load set is transferred to the full model, a linear static load is performed and the internal stress distribution is derived.

For each landing simulation, landing gear reactions were obtained at the corresponding attachment points and, subsequently, they were used as forcing functions for the evaluation of the fuselage loads.

To illustrate typical results, the time history of the landing gear reactions are reported in Figure 6 for the landing condition TD_VL2 with MLW weight configuration, where the sign convention is based on the reference systems of Figure 3(a).

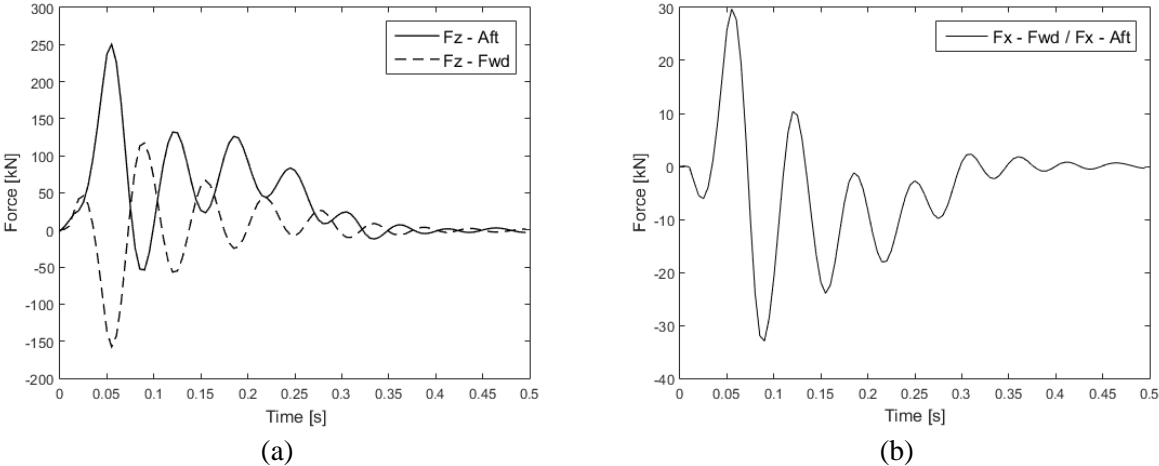

Figure 6. Time history of the main landing gear reactions: (a) vertical component Z, (b) horizontal component X.

5.1 Fuselage Load Envelopes

The fuselage design is performed by monitoring the loads at different fuselage stations.

Each of the eight landing conditions analyzed is composed of 100 time points, thus giving an overall number of 800 loading conditions.

The load case at maximum design landing weight (MLW), tail down, and hot and high condition was identified as the critical one. The same landing condition was used for comparison purposes in the section devoted to the analysis of the fully dynamic design procedure.

The loads of the critical case are then applied to the 3D shell model in the form of static counterparts, and a linear static analysis is performed with the NASTRAN SOL 101 solver. The resultant stress distribution is shown in Figure 7 in terms of component y of the stress tensor. The deformed shape of the complete aircraft is presented in Figure 8.

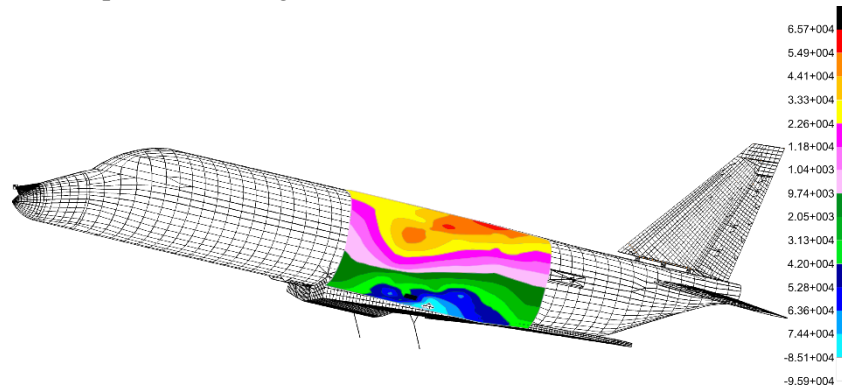

Figure 7. σ_y stress values for static baseline condition.

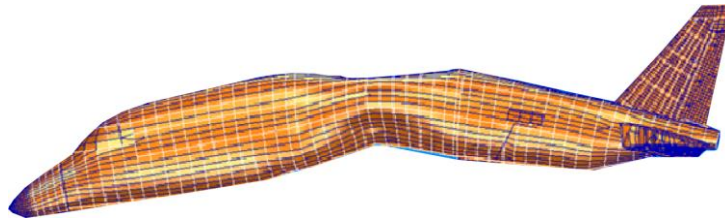

Figure 8. Deformed shape of the model for the static baseline condition.

6. New Procedure Based on Dynamic Loads

A novel approach based on a fully dynamic approach was developed. The goal of the investigation is to check whether a weight reduction is possible in comparison to the current design methodology based on simplified models and equivalent static loads.

The dynamic response analysis is based on the 3D shell model, whose picture is presented in Figure 4(b), specifically developed within the DAEDALOS project.

As summarized in Figure 5, the approach is based on a direct transient analysis of the 3D shell model, which is performed using the MSC NASTRAN SOL 109 solution. The forcing function are represented by the reactions at the main landing gear attachments obtained by means of the specific landing simulation code discussed in Section 3.

[In the full dynamic approach, the stress distribution in the fuselage elements is directly available from the analysis results in the form of time history. The critical time frame is selected as the one corresponding to the peak stress values, which are then compared with those obtained using the static method.

6.1 Forcing Functions

As for the standard approach, the forcing functions are the time histories of the reactions at the main landing gear attachment. In the context of the approach outlined in Section 4, the reactions are obtained from the landing simulation results, making use of the stick model of the aircraft attached to the non-linear landing gear model.

6.2 Damping Modeling

As part of the fully dynamic approach, the effects due to energy dissipation are assessed to determine the impact of damping on the final design. In this context, two types of damping are usually introduced to model the response of linearly-elastic material: the viscous and structural damping. In particular, the viscous force is proportional to the velocity, and its expression is given by:

$$f_v = b\dot{u} \quad (1)$$

where f_v denotes the viscous force, b is the damping coefficient and \dot{u} is the velocity.

On the other hand, the structural damping force is proportional to the displacement and is given by:

$$f_s = i G k u \quad (2)$$

where G is the structural damping stiffness coefficient, k is the stiffness, u is the displacement and i is the imaginary unit.

From the expression of Eqs. (1) and (2), it is observed that, for a sinusoidal displacement response of constant amplitude, the structural damping force is constant. On the other hand, the viscous damping force is proportional to the forcing frequency. It follows that one single frequency exists, hereinafter denoted as ω_3 , associated to the identical damping forces f_v and f_s . A graphical representation of the viscous and structural damping forces is presented in Figure 9.

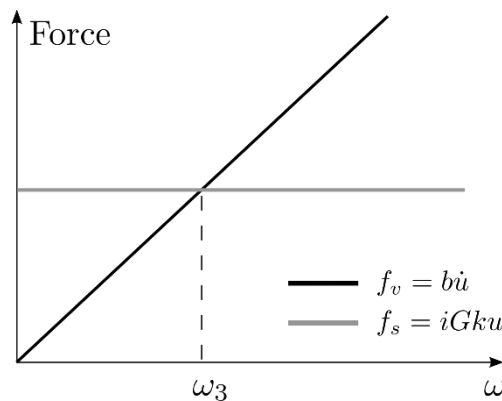

Figure 9. Structural damping versus viscous damping.

While a frequency-independent damping can be sought as a good approximation of the dissipative phenomena involved in the aircraft response, the present dynamic analysis is performed in the time domain. It follows that the structural damping, which is defined in the frequency domain, should be converted into an equivalent viscous counterpart.

In NASTRAN, the parameters G and ω_3 are defined using the cards PARAM G and PARAM W3, so that the equivalence between viscous and structural damping is guaranteed at the frequency level corresponding to ω_3 . Below this frequency value, the system is underdamped, and beyond the system is overdamped.

The choice of the most appropriate frequency value ω_3 cannot be easily established a priori. In fact, the response of the DAEDALOS aircraft to the impact loading involves a relatively large number of modes. To face this uncertainty, a number of analysis has been performed by considering different values of ω_3 and G, so that the sensitivity of the response to these parameters could be assessed.

7. Results and Comparison with Static-Based Approaches

Direct transient analyses were performed for the critical landing condition considering different damping values. A total number of 21 analyses were performed, and the stress distribution was monitored for the elements composing the fuselage section under investigation. A typical result is shown in Figure 10, where the distribution of the stress component σ_y is shown at the most critical time frame for damping values G=0.05 and frequency $\omega_3=21$ Hz. Analogously, stress distributions are derived for the other conditions here considered.

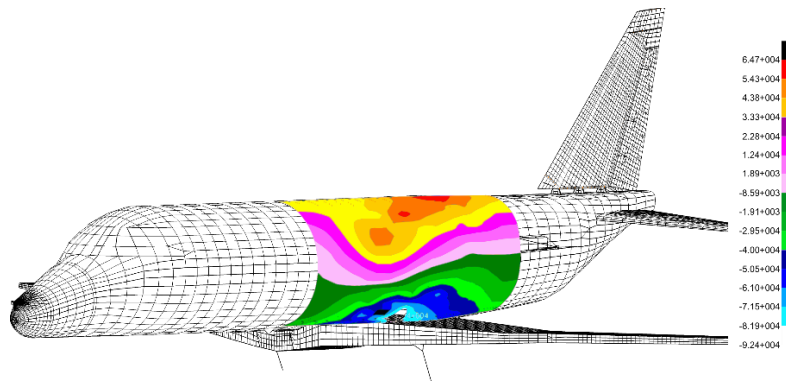

Figure 10. σ_y stress values for dynamic solution with G=0.05 and $\omega_3=21$ Hz.

It was observed that all the peak stresses are registered simultaneously, at the same time frame ($t=0.055$ s). Therefore, all the design stresses are relative to the corresponding single time frame.

To check the differences between the dynamic and the standard approaches, the peak stresses were compared with the results from the baseline static analysis. As a means to assess the potential improvements due to the fully dynamic approach, the stress ratio r_1 was defined as:

$$r_1 = \frac{\sigma_y^{\text{dyn}}}{\sigma_y^{\text{ref}}} \quad (3)$$

where σ_y^{ref} denotes the stress obtained using the standard procedure, while σ_y^{dyn} denotes peak stress determined with the dynamic approach. The nondimensional parameter r_1 was computed for all the elements composing the 3D shell model. A typical plot for different $\omega_3=12$ Hz and G=0.05 is shown in Figure 11, where r_1 is shown versus the peak stress value. Due to a large scatter of the ratio r_1 in for small stress magnitudes, only results with stress values exceeding ± 20 MPa are shown.

Plots in the form of Figure 11 are obtained for all the conditions analyzed, corresponding to the different combinations of damping values G and frequency values ω_3 .

To derive useful design guidelines, a linear approximation was adopted to describe the behavior of r_1 versus the peak value, both for the elements in tension and those in compression. Interpolated data are then used to determine the mean value of r_1 for each of the 21 conditions analyzed. A plot summarizing the results is shown in Figure 12, where the mean value of r_1 is shown versus the frequency ω_3 . Each curve corresponds to a different value of the structural damping stiffness coefficient G.

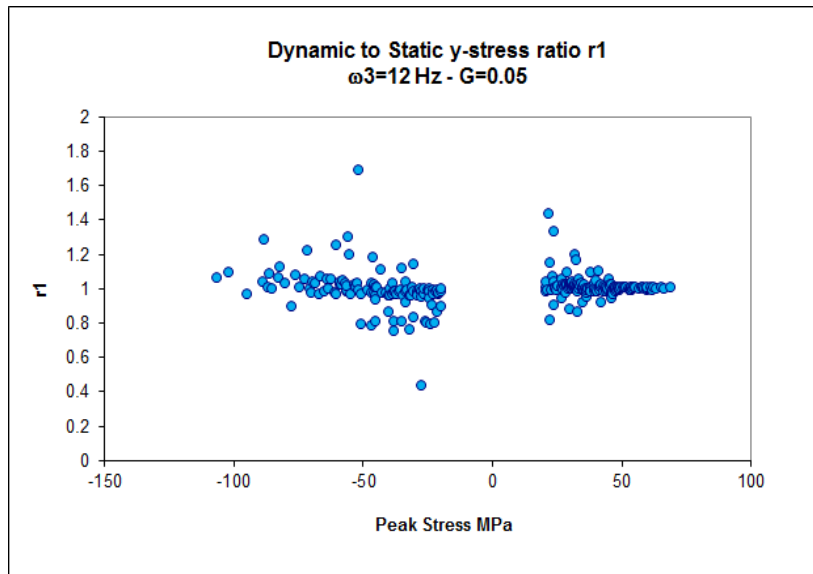

Figure 11. Dynamic to static stress ratio r_1 for $\omega_3=12$ Hz, $G=0.05$

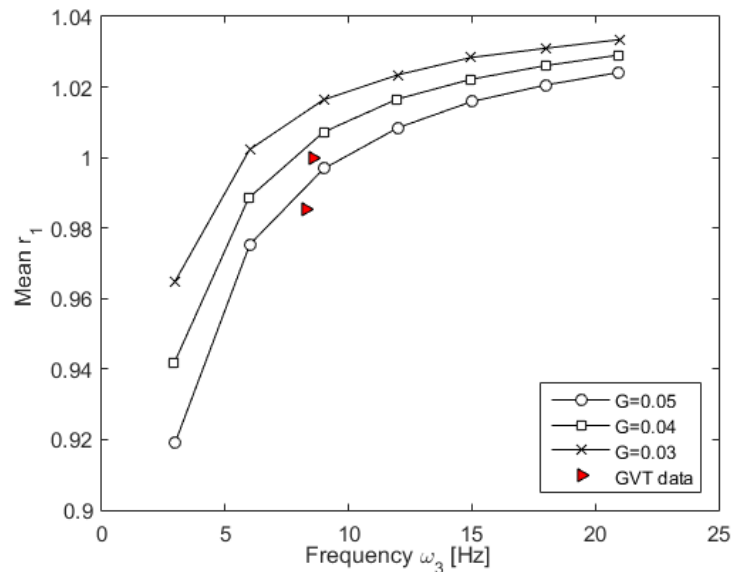

Figure 12. Mean values of the dynamic-to-static stress ratio for different values of damping.

From the results of Figure 12 it is observed that the ratio r_1 increases monotonically with the frequency parameter ω_3 . It is worth highlighting that, for small values of ω_3 , the parameter r_1 is smaller than 1. In this case, the stress peaks obtained with the dynamic approach are smaller than those available from the baseline procedure and, therefore, represent conditions where weight reduction could be achieved. As expected, the three curves of Figure 12 demonstrate the beneficial effects due to an increased damping level. Indeed, higher values of damping ratio G lead to smaller values of r_1 , corresponding to an increased stress reduction due to the dynamic approach.

The dependence of the results of Figure 12 on the values of ω_3 demonstrates that considerations regarding any potential weight reduction are strongly dependent on the choice of ω_3 . In principle, the most adequate value should be determined, for a given configuration, on the basis of the frequency content analysis of the structural time response.

In the present investigation, the critical elements for the design display a similar time response, characterized by a peak stress value at the time frame 0.055 s. These responses can be associated to a frequency of approximately 7-8 Hz. From Figure 12, it can be observed that, in this frequency range, the stress ratio r_1 is smaller than 1, thus suggesting the possibility of achieving a slight weight reduction.

For sake of completeness, typical damping values obtained from the ground vibration test of a medium business jet are reported in Figure 12. The two points are representative of the damping coefficients measured for two fuselage modes of a similar aircraft. In this case, the two values are slightly smaller than the unity, confirming the potentialities for a slight load reduction.

8. Conclusions

The results of the present investigation illustrate that a certain, although limited, amount of load reduction can be achieved if a dynamic response analysis of the full aircraft is adopted.

For the aircraft model used in DAEDALOS, a relatively limited amount of load reduction can be achieved but, in general, the reduction could be more relevant for larger and more flexible aircrafts with lower natural frequencies.

The damping characteristics of the 3D shell model have been identified as the main factor contributing to a potential load reduction. For this reason, a refined numerical and experimental description of the damping is key to obtain valid and practical conclusions regarding the possibility of reducing the design loads. Based on the studies conducted during the DAEDALOS project, guidelines were derived for a methodology for loads redistribution.

The present study represents a first step into the definition of a novel design procedure based on dynamic analyses since the early phases. This topic covers different aspects, ranging from numerical to experimental procedures. Some of these issues have been partially covered during the DAEDALOS project, but further research activity is still needed. In particular, a deeper investigation is suggested with regard to damping effects, both in term of its experimental evaluation as well as its numerical modelling. Nonlinearities and buckling effects could be part of future analyses, despite the complicating effects due to the need of even complex finite element models.

References

1. European Aviation Safety Agency (EASA): Certification Specification for Large Aeroplanes CS-25 (Amdt. 10, 23 December 2010) - <http://www.easa.eu.int/index.php>.
2. Federal Aviation Regulations - Title 14 Aeronautics and Space – Part 25 (FAR 25)
3. MSC/NASTRAN: User's Manual.
4. Bronstein M., Feldman E., Vescovini R., and Bisagni C., “Assessment of dynamic effects on aircraft design loads: The landing impact case”, Progress in Aerospace Sciences (2015), <http://dx.doi.org/10.1016/j.paerosci.2015.06.003i>