

**Predictive Aircraft Maintenance  
Modeling and Analysis Using Stochastic Petri Nets**

Lee, J.; Mitici, M.A.

**DOI**

[10.3850/978-981-18-2016-8\\_050-cd](https://doi.org/10.3850/978-981-18-2016-8_050-cd)

**Publication date**

2021

**Document Version**

Accepted author manuscript

**Published in**

Proceedings of the 31st European Safety and Reliability Conference

**Citation (APA)**

Lee, J., & Mitici, M. A. (2021). Predictive Aircraft Maintenance: Modeling and Analysis Using Stochastic Petri Nets. In B. Castanier, M. Cepin, D. Bigaud, & C. Berenguer (Eds.), *Proceedings of the 31st European Safety and Reliability Conference* (pp. 146-153). (Proceedings of the 31st European Safety and Reliability Conference, ESREL 2021). ESREL. [https://doi.org/10.3850/978-981-18-2016-8\\_050-cd](https://doi.org/10.3850/978-981-18-2016-8_050-cd)

**Important note**

To cite this publication, please use the final published version (if applicable).  
Please check the document version above.

**Copyright**

Other than for strictly personal use, it is not permitted to download, forward or distribute the text or part of it, without the consent of the author(s) and/or copyright holder(s), unless the work is under an open content license such as Creative Commons.

**Takedown policy**

Please contact us and provide details if you believe this document breaches copyrights.  
We will remove access to the work immediately and investigate your claim.

## Predictive aircraft maintenance: modeling and analysis using stochastic Petri nets

Juseong Lee

*Aerospace Engineering, Delft University of Technology, The Netherlands. E-mail: J.Lee-2@tudelft.nl*

Mihaela Mitici

*Aerospace Engineering, Delft University of Technology, The Netherlands. E-mail: M.A.Mitici@tudelft.nl*

Predictive aircraft maintenance is a complex process, which requires the modeling of the stochastic degradation of aircraft systems, as well as the dynamic interactions between the stakeholders involved. In this paper, we show that the stochastically and dynamically colored Petri nets (SDCPNs) are able to formalize the predictive aircraft maintenance process. We model the aircraft maintenance stakeholders and their interactions using local SDPCNs. The degradation of the aircraft systems is also modeled using local SDPCNs where tokens change their colors according to a stochastic process. These SDPCN models are integrated into a unifying SDPCN model of the entire aircraft maintenance process. We illustrate our approach for the maintenance of multi-component systems with k-out-of-n redundancy. Using SDPCNs and Monte Carlo simulation, we analyze the number of maintenance tasks and potential degradation incidents that the system is expected to undergo when using a remaining useful life(RUL)-based predictive maintenance strategy. We compare the performance of this predictive maintenance strategy against other maintenance strategies that rely on fixed-interval inspection tasks to schedule component replacements. The results show that by conducting RUL-based predictive maintenance, the number of unscheduled maintenance tasks and degradation incidents is significantly reduced.

*Keywords:* Aircraft maintenance, Predictive maintenance, Stochastic Petri nets, Reliability, Modeling, Simulation.

### 1. Introduction

With the increasing use of on-board sensors to monitor the health of aircraft systems and components, aircraft maintenance is shifting to *predictive* aircraft maintenance (PdM) (Alaswad and Xiang, 2017). Under the PdM paradigm, the health condition of aircraft components is monitored by sensors and the collected data is analyzed to predict the remaining-useful-life (RUL) of these components. Using RUL prognostics, maintenance tasks are scheduled in anticipation of component failures. Several studies have been performed in the past years to model and analyze PdM (Ran et al., 2019).

However, aircraft maintenance is a complex process which requires the modeling of both the stochastic degradation of aircraft systems and components, as well as the dynamic interactions between the stakeholders involved (Lee and Mitici, 2020). Appropriate models to capture the degradation trends of systems and components need to be proposed using available sensor monitoring data. These degradation models are further analyzed by a team of engineers which specifies maintenance tasks to address anticipated maintenance issues. These maintenance tasks are scheduled by a planning team, based on the availability of the aircraft and maintenance resources. Once a task schedule is available, mechanics execute

these tasks. All these interactions between stakeholders need to be modeled to analyze the aircraft maintenance process.

Complex processes, as is the case for the aircraft maintenance process, are often modeled by means of stochastically and dynamically colored Petri nets (SDCPNs) (?). One of the reasons is that SDPCNs are able to model stochastic systems, such as the degradation of aircraft components (Lee and Mitici, 2020). Also, SDPCNs are able to model multiple, interacting stakeholders of a complex process (Mitici and Blom, 2019). Furthermore, a large process can be modeled in a modular manner, using local SDPCNs (Sheng and Prescott, 2019). Ultimately, these local SDSPNs are integrated in one, unifying SDPCN of the entire process. This approach is particularly suitable for the aircraft maintenance process, where individual stakeholders can be modeled using local SDPCNs, while their interactions are still captured by the integration of these SDPCNs (Lee and Mitici, 2020).

In this paper, we model and analyze the aircraft predictive maintenance process using stochastically and dynamically colored Petri nets. We focus on the modeling of interactions between five main stakeholders involved in the aircraft maintenance process: the task generating team, the task planning team, the mechanics team, the flight

2 *J.Lee and M.Mitici*

crew, and the data management team. The data management team is a stakeholder specific for the predictive aircraft maintenance paradigm. For each stakeholder, we construct a local SDCPN. These local SDCPNs are integrated into one SDCPN of the entire aircraft maintenance process. Using this SDCPN and Monte Carlo simulation, we analyze predictive maintenance strategies for multi-component aircraft systems with a  $k$ -out-of- $n$  redundancy. Under predictive maintenance, the RUL of the components are predicted using a data-driven regression model. Based on the RUL prognostics, components replacements are scheduled. For the purpose of comparison, we also analyze two other maintenance strategies, which are commonly used in the practice of aircraft maintenance. Under these strategies, fixed-interval inspections are scheduled to assess the health condition of the components, before deciding to perform a component replacement. The result shows that by performing RUL-based predictive maintenance, the number of unscheduled maintenance tasks and degradation incidents is limited, compared to the other maintenance strategies that rely on fixed-interval inspections.

## 2. Modeling the Predictive Aircraft Maintenance Process

### 2.1. Stakeholders

Aircraft maintenance is a complex process involving many teams of experts with different roles. All these teams contribute to the maintenance of aircraft based on a given maintenance strategy. Traditionally, maintenance is performed using time-based maintenance (TBM) strategies with fixed-interval inspections (Huynh et al., 2011). Novel, predictive maintenance (PdM) strategies determine the moment of component replacements based on the analysis of sensor data on the health of systems and remaining-useful-life (RUL) prognostics (Lee and Mitici, 2020). Thus, the way of working of each maintenance team is determined by the maintenance strategy adopted.

The main stakeholders involved in the aircraft maintenance process are (Lee and Mitici, 2020):

- Task generating team (TG)
- Task planning team (TP)
- Mechanics team (ME)
- Flight crews (CR)
- Data Management team (DM)

Fig. 1 shows the interactions between the aircraft maintenance stakeholders who monitor and analyze the condition of the aircraft. The task generating team (TG) receives feedback coming from the flight crews (CR), the mechanics team (ME), and the data management team (DM). With this, the TG specifies what type of maintenance tasks are necessary to perform and what are the deadlines

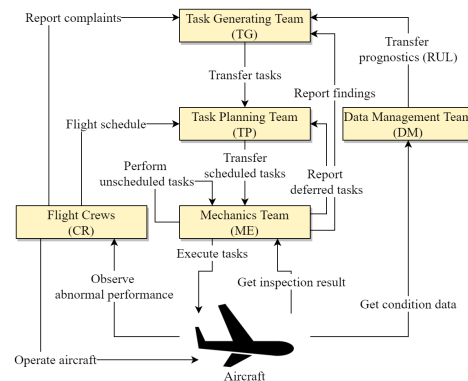

Fig. 1. Interactions of the stakeholders involved in aircraft maintenance.

for these tasks. They communicate these tasks to the task planning team (TP). The TP schedules the maintenance tasks based on the deadlines specified by the TG, the flight schedules of the aircraft, and the availability of the ME. Lastly, the ME performs the maintenance tasks scheduled by the TP. The ME may identify during inspections additional tasks that need to be performed. Such an unexpected task may be performed on-site as an *unscheduled task*, or reported to the TP so that it is scheduled at a later moment.

The data management team (DM) is an additional stakeholder that supports predictive aircraft maintenance. The DM manages the data collected by on-board sensors on the health condition of aircraft systems, analyzes these data, predicts RUL of components and provides feedback to the TG.

### 2.2. SDCPN models

The aircraft maintenance process with the stakeholders identified in Sec. 2.1 are modeled and formalized by means of stochastically and dynamically colored Petri nets (SDCPNs). SDCPNs allow the modeling of stochastic and dynamic processes (?), which is the case for aircraft maintenance.

An SDCPN is a graph that consists of two sets of nodes, *places* and *transitions*. Each place represents a potential status of a stakeholder. A place may have *tokens*, which represent the current status of the stakeholder. The status may be further described by the additional variables attached to the tokens, which is referred to as the *color* of the tokens. These tokens move from one place to another place when a transition is triggered. There are three types of transitions used for SDCPNs: i) immediate transition triggered immediately when it is enabled, ii) delay transition triggered after a stochastic delay, and iii) guard transition triggered when the color (variables) of the tokens satisfy certain conditions. These transitions are enabled

by tokens located in the places connected to them through directed arcs.

SDCPNs also make use of three types of arcs. An ordinary arc transfers a token. Enabling and inhibitor arcs do not transfer a token, but indicate the condition under which a transition can be triggered. If and only if all places connected to a transition by enabling arcs have tokens, then this transition can be triggered. Inhibitor arcs work the other way around, i.e., a transition cannot be triggered if any place connected by an inhibitor arc has tokens. The graphical representation of these SDCPN elements is given in Fig. 2.

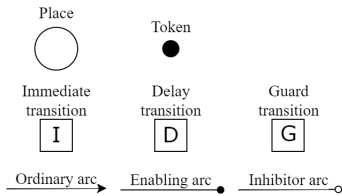

Fig. 2. Elements of SDCPN.

Fig. 3 shows examples of conditions when transitions are triggered. In the case (a), the immediate transition is triggered immediately as all the connected places have tokens. These tokens are removed after the transition, and a new token is generated in the place by the ordinary arc. In the case (b), the delay transition is triggered after stochastic delay, but the token in the place connected by enabling arc is not moved. In the case (c), the transition cannot be triggered because a token is located in the place connected

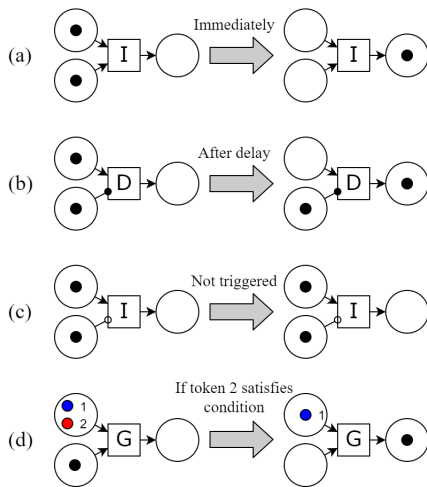

Fig. 3. Examples of conditions when transitions are triggered.

by an inhibitor arc. In the case (d), the guard transition check the color (variables) attached to the token 1 and 2. This transition is fired only if there is a token that satisfies a pre-defined condition.

In the following sections, we describe the SDCPN models of an aircraft, and the five stakeholders defined in Sec. 2.1.

### 2.2.1. SDCPN model of Aircraft

Fig. 4 shows an SDCPN model of an aircraft equipped with sensor monitoring capabilities. It consists of three parts, each representing the operational status of aircraft, the health condition of aircraft components, and the condition monitoring sensors.

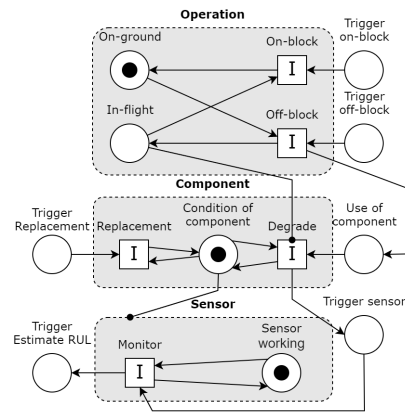

Fig. 4. SDCPN model of aircraft.

An aircraft has two operational modes: ‘In-flight’ and ‘On-ground’. An on-ground aircraft switches to the in-flight mode when the flight crew (CR) triggers the transition ‘Off-block’. Similarly, the aircraft switches to the on-ground mode when the CR triggers the transition ‘On-block’.

When the aircraft is in-flight, the health condition of the aircraft components degrades following a stochastic process, i.e., transition ‘Degrade’ is triggered. This updates the token in the place ‘Condition of component’. The color of this token describes the current degradation level  $Z(t)$  of the component.

We consider components that undergo a continuous and stochastic degradation process such as bearings that wear out over time, or brake pads that erode over time. In this study, we model the component degradation process using a Gamma process (van Noortwijk, 2009). A new component without any degradation has  $Z(t) = 0$ . The degradation increases during the aircraft is in-flight. The degradation accumulated during a flight with departure and arrival times  $t^{dep}$  and  $t^{arr}$  is,

$$Z(t^{arr}) - Z(t^{dep}) \sim \text{Gamma}(\alpha, \beta), \quad (1)$$

where  $\alpha$  and  $\beta$  are the shape and the scale parameter of the Gamma process. If  $Z(t) \geq \eta$ , where  $\eta$  is a threshold, then we assume that the component is *inoperable*.

When the mechanics team (ME) triggers a component replacement, the transition ‘Replacement’ is triggered, resetting the degradation level to  $Z(t) = 0$ .

Also, we assume that an aircraft is equipped with sensors that monitors the degradation levels  $Z(t)$  of components with a certain level of error. Formally, the degradation level observed by sensors is  $\tilde{Z}(t) = Z(t) + \epsilon_{Sen}$ , with the sensor error  $\epsilon_{Sen} \sim \mathcal{N}(0, \sigma_{Sen}^2)$ .

**2.2.2. SDCPN model of multi-component system with  $k$ -out-of- $n$  redundancy**

The SDCPN model of aircraft in Fig. 4 shows only one component, but aircraft generally consist of multi-component systems. We say that a multi-component system has  $k$ -out-of- $n$  redundancy if the system consists of  $n$  components and requires at least  $k$  operable components, ( $0 < k \leq n$ ).

When more than  $(n - k)$  components become inoperable in a system with  $k$ -out-of- $n$  redundancy, we say that a *degradation incident* occurs. When a degradation incident occurs, the aircraft needs prompt maintenance before it can start a new flight. For example, the landing gear brakes system of wide-body aircraft has 3-out-of-4 redundancy on each side of the aircraft, i.e., at most 1 inoperable brake is allowed on each side of the aircraft (see Fig. 5).

The SDCPN model of the aircraft in Fig. 4 is readily adapted for multi-component systems by duplicating the component part of this model  $n$  times, as shown in Fig. 5. In this way, the SDCPN model is easily adjustable for different aircraft systems.

**2.2.3. SDCPN model of task generating team**

The task generating team (TG) specifies the types of maintenance tasks that need to be performed and the tasks’ deadlines. The SDCPN model of

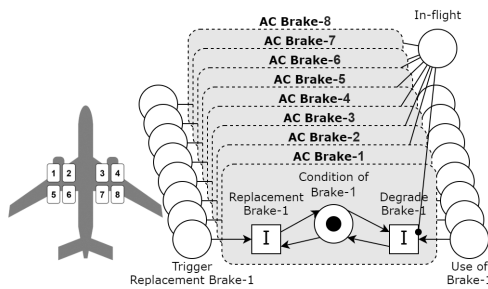

Fig. 5. SDCPN model for the landing gear brakes of a wide-body aircraft.

the TG is shown in Fig. 6. Feedback is coming from the DM, the ME, and the CR. Each feedback triggers the associated transitions, and generates a task token in the place ‘Task to plan’.

In this study, we consider two types of maintenance tasks: component replacement and visual inspections of components. The type and deadlines of the generated tasks are determined based on the given maintenance strategy. For example, under a TBM strategy, a task token of an inspection is generated at every fixed time-interval. Under a PdM strategy, a task token to replace a component is generated based on the feedback (sensor data analysis, RUL prognostics) from the DM.

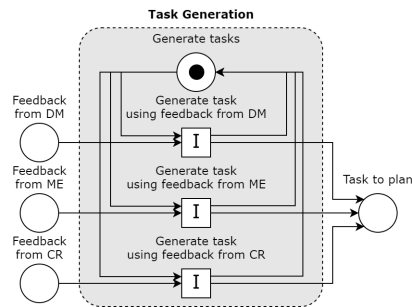

Fig. 6. SDCPN model of the task generating team.

**2.2.4. SDCPN model of task planning team**

The task planning team (TP) specifies when to execute the tasks generated by the TG. Fig. 7 shows the SDCPN model of the TP. The TP receives the flight schedule from the CR, and the tasks type and tasks deadline from the TG. Then, it identifies a moment when the aircraft is on-ground, the ME is available to perform the task, and the deadline of the task is not exceeded. Finally, the transition ‘Plan task’ generates a token in the place ‘Task to execute’.

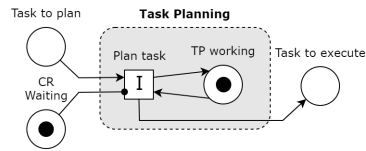

Fig. 7. SDCPN model of the task planning team.

**2.2.5. SDCPN model of mechanics team**

The mechanics team (ME) executes the tasks scheduled by the TP. The SDCPN model of the

ME is given in Fig. 8. When a token is generated by the TP in the place ‘Task to execute’ and the ME is in ‘Waiting’, the ME executes this task. Depending on the type of the task, a component replacement or a visual inspection is performed.

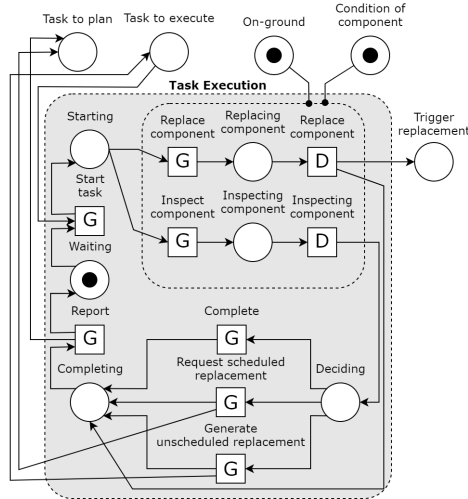

Fig. 8. SDCPN model of the mechanics team.

When a component replacement is performed, the degradation level of the component is reset to  $Z(t) = 0$ . To represent this in an SDCPN, a token generated in the place ‘Trigger replacement’ in Fig. 8 triggers the transition ‘Replacement’ of the SDCPN model of the aircraft (see Fig. 4), updating the token in the place ‘Condition of component’.

When a component inspection is performed, the ME observes the degradation level of the component. This observation is performed with an error, i.e.,  $\hat{Z}(t) = Z(t) + \epsilon_{Ins}$ , where  $\epsilon_{Ins} \sim \mathcal{N}(0, \sigma_{Ins}^2)$ . If the component degradation exceeds a threshold  $\eta$  (inoperable components), the ME performs an unscheduled component replacement. If the component is still operable ( $\hat{Z}(t) < \eta$ ), the ME makes decisions based on a given maintenance strategy. For example, the ME may request a scheduled replacement before the component is inoperable if the degradation level is higher than a threshold  $\eta_{Rep}$  specified by the maintenance strategy, i.e.,  $\eta_{Rep} \leq \hat{Z}(t) < \eta$ .

2.2.6. SDCPN model of data management team

For predictive aircraft maintenance, an additional stakeholder is involved: the data management team (DM). This stakeholder is usually not present when traditional, time-based maintenance is performed. The DM monitors, collects and analyzes

the sensor-monitoring data on the health condition of the aircraft systems. This data is used to estimate the RUL of the components, and to alert the TG when the component degradation is high. Fig. 9 shows the SDCPN model of the DM. Here, the guard transition checks a degradation data collected by the on-board sensors. Once this exceeds a threshold specified in the predictive maintenance strategy, the DM provides feedback to the TG.

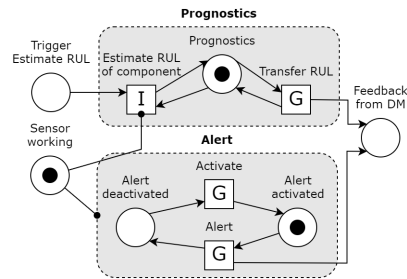

Fig. 9. SDCPN model of the data management team.

2.2.7. SDCPN model of flight crews

The flight crews (CR) operate the aircraft following a pre-defined flight schedule. They also report any abnormal degradation of components after each flight. Fig. 10 shows the SDCPN model of the CR. This model is connected to the aircraft model in Fig. 4 through two places, ‘Trigger off-block’ and ‘Trigger on-block’. Also, the transition ‘Depart’ cannot be triggered if the place ‘Replacing’ or ‘Inspecting’ has a token. In other words, the CR cannot depart until the on-going maintenance is completed.

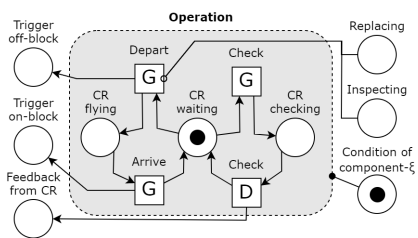

Fig. 10. SDCPN model of the flight crews.

2.3. Stakeholders’ interaction and the integration of the SDCPN models

The interactions between these stakeholders are modeled by integrating the individual SDCPN models into a large SDCPN model of the predictive aircraft maintenance process. For this integration, the places with the same names in Fig. 4-10,

are connected. For instance, when the TG (Fig. 6) generates a task by giving a token in place ‘Task to plan’, this token triggers the transition ‘Plan task’ of the TP (Fig. 7). Similarly, a token in place ‘Task to execute’, which is generated by the TP, initiates the ME (Fig. 8) to start the given task. In this manner, one local SDCPN model affects another SDCPN model, illustrating the dynamic, interactive process of aircraft maintenance.

### 3. Aircraft Maintenance Strategies

The interactions and the way of working of the stakeholders is governed by a given maintenance strategy, i.e., the stakeholders act according to a given maintenance strategy. For example, let’s assume that a given maintenance strategy requires the ME to report to the TP if the degradation level of a component is higher than a threshold  $\eta_{\text{Rep}}$ , so that the component replacement can be scheduled. Under this maintenance strategy, the guard transition ‘Request scheduled replacement’ of the SDCPN model of the ME (Fig. 8) is triggered if the token in the place ‘Deciding’ describes the inspection result such that  $\hat{Z}(t) \geq \eta_{\text{Rep}}$ . This transition generates a task token in the place ‘Task to plan’, which will trigger transition ‘Plan task’ in the SDCPN model of the TP (Fig. 7). On the other hand, if  $\hat{Z}(t) < \eta_{\text{Rep}}$ , then the transition ‘Complete’ is triggered, which does not trigger any transitions of the TP. This is an example where the SDCPN models of the stakeholders can be used for various maintenance strategies.

In this study, we consider three types of maintenance strategies, ranging from novel, predictive maintenance strategies to traditional, time-based maintenance strategies.

#### *RUL-based replacement strategy*

The RUL-based replacement (RBR) strategy determines the moment of component replacement based on data analytics (Lee and Mitici, 2020; Pater and Mitici, 2021). Under RBR strategy, the DM monitors the degradation levels of aircraft components using sensors, and estimates RUL of components by analyzing the sensor data. If this RUL is less than a threshold  $\rho_{\text{Rep}}$ , then the DM notifies TG, triggering a component replacement.

The DM estimates RUL of a component based on the recorded sensor data on the degradation of a component  $\{\tilde{Z}(t') \text{ for } 0 < t' \leq T\}$ , with  $T$  the current time. The following linear regression model is considered to predict the future degradation level at time  $T + t$ ,

$$\tilde{Z}(T + t) = c_0 + c_1 t. \quad (2)$$

The coefficients  $c_0$  and  $c_1$  are updated after every flight cycle using the ordinary least square

method. Then, the RUL of the component is estimated as,

$$\text{RUL} = \min\{t | c_0 + c_1 t \geq \eta\}. \quad (3)$$

The RBR strategy is a predictive maintenance type of strategy that exploits data analytics. It does not rely on visual inspection tasks periodically performed by mechanics, as it predicts future degradation trends (RUL) using sensor data. Based on these predictions, component replacements are scheduled.

#### *Sensor-based inspection strategy*

The sensor-based inspection (SBI) strategy relies on both sensors monitoring and visual inspection tasks, to decide to replace a component (Lee and Mitici, 2020). Under the SBI strategy, the TG generates periodic inspections once it is notified by the DM that the sensor data analysis indicates a high degradation level, i.e.,  $\tilde{Z}(t) \geq \eta_{\text{Ins}}$ . Once the DM sends a notification to the TG team, the TG generates inspection tasks at every  $D_{\text{Ins}}$  flight cycles (FCs). These inspections are performed by the ME. If the ME identifies during an inspection a degradation level  $\hat{Z}(t)$  that exceeds a threshold  $\eta_{\text{Rep}}$ , then they also submit a request to TP to schedule a component replacement (see also Fig. 8).

The SBI strategy aims to limit the number of visual inspection tasks. For this, when the degradation level is low ( $\tilde{Z}(t) < \eta_{\text{Ins}}$ ), the components are monitored only using sensors, instead of the inspection tasks. However, the final decision to perform component replacement is based on the inspection results, instead of the analysis of the sensor data.

#### *Fixed-interval inspection strategy*

For comparison reasons, we also consider a traditional, time-based maintenance strategy named fixed-interval inspection (FII) strategy. The FII strategy rely on the periodic inspections to determine the moment of component replacement (Huynh et al., 2011). Under FII strategy, the TG generates inspection tasks every  $D_{\text{Ins}}$  flight cycles (FCs). Similar to the SBI strategy, the ME request the TP to schedule a component replacement if the degradation level exceeds a threshold  $\eta_{\text{Rep}}$ . Often the interval of the inspections  $D_{\text{Ins}}$  is set to be short to timely identify inoperable components .

### 4. Key Performance Indicators of Predictive Aircraft Maintenance

The three types of maintenance strategies in Sec. 3 are assessed based on several key performance indicators (KPIs). In this study, instead of translating all KPIs into monetary values, we consider the following individual KPI explicitly. This allows analyzing the trade-offs between the KPIs.

### Number of maintenance tasks

The number of maintenance tasks performed directly affects the overall maintenance cost because the execution of a task requires the assignment of qualified mechanics team, the purchase of new components in the case of replacement, etc. In particular, the number of component replacements is crucial since this accounts for the largest part of the total maintenance cost (Crowder and Lawless, 2007). We denote by  $N_{\text{Rep.}}$  and  $N_{\text{Ins.}}$  the number of replacements and inspections per year per aircraft, respectively.

### Number of unscheduled maintenance tasks

Unscheduled maintenance tasks result in additional costs, flight delays and disturbances to the flight schedules (Lee and Mitici, 2021). Thus, it is desirable to limit the number of unscheduled maintenance tasks. In the SDCPN model of the ME in Fig. 8, if the mechanics identify degradation higher than a threshold  $\eta$ , then an unscheduled replacement is generated. We denote by  $N_{\text{Unsch.}}$  the average number of unscheduled component replacements.

### Number of degradation incidents

We consider the degradation incidents defined in Sec.2.2.1. For multi-component systems with  $k$ -out-of- $n$  redundancy, a degradation incident occurs if more than  $k$ -out-of- $n$  components become inoperable ( $Z(t) \geq \eta$ ). Since an aircraft with a degradation incident needs immediate maintenance, additional costs and flight delays are expected when such incidents occur. Thus, it is of interest to reduce the number of degradation incidents, denoted by  $N_{\text{Inci.}}$  (Lee and Mitici, 2021).

## 5. Case Study: Maintenance of Aircraft Landing Gear Brakes

As a case study, we consider the maintenance of the landing gear brakes of an aircraft. The aircraft is equipped with 8 brakes as shown in Fig. 5. Each system of 4 brakes on left/right side of the aircraft has  $k$ -out-of- $n$  redundancy. The degradation of the brakes is modeled using a Gamma process (Lee and Mitici, 2020).

We assess the KPIs of the RBR, SBI and FII maintenance strategies for the landing gear brakes using the SDCPN models in Sec. 2.2 and Monte Carlo simulation. Thus, the KPIs are evaluated as the expected values obtained by Monte Carlo simulations.

For the RBR strategy, we assume that the threshold to schedule a replacement is  $\rho_{\text{Rep.}} = 30_{\text{FCs}}$ . For the SBI strategy we assume two different thresholds to start periodic inspections,  $\eta_{\text{Ins}} = 0.9$  and  $\eta_{\text{Ins}} = 0.95$ . For the FII strategy, we assume  $D_{\text{Ins}} = 50_{\text{FCs}}$ , as well as  $D_{\text{Ins}} = 25_{\text{FCs}}$  to

identify the impact of more frequent inspection. We consider the KPIs of the FII strategy with  $D_{\text{Ins}} = 50_{\text{FCs}}$  as a baseline to compare the performance of the other strategies since the FII strategy is strategies commonly used in the practice of aircraft maintenance (Lee and Mitici, 2020).

Table 1 shows the performance of the RBR, SBI and FII maintenance strategies with respect to the number of replacements  $N_{\text{Rep.}}$  and inspections  $N_{\text{Ins.}}$ , number of unscheduled maintenance  $N_{\text{Unsch.}}$  and degradation incidents  $N_{\text{Inci.}}$ .

Fig. 11 shows the KPIs of the considered strategies in a radar chart. Since all KPIs need to be minimized, the maintenance strategy associated with the smallest area has the highest performance.

The results show that the RBR strategy outperforms the FII strategy, especially in terms of the number of degradation incidents  $N_{\text{Inci.}}$  and unscheduled maintenance  $N_{\text{Unsch.}}$ . A low  $N_{\text{Inci.}}$  and  $N_{\text{Unsch.}}$  indicate that, under the RBR strategy, the brakes are mainly replaced before they exceed their degradation threshold  $\eta$ . At the same time,

Table 1. KPIs of the maintenance strategies RBR, SBI and FII.

Strategy	$N_{\text{Rep.}}$	$N_{\text{Ins.}}$	$N_{\text{Unsch.}}$	$N_{\text{Inci.}}$
RBR, $\rho_{\text{Rep.}} = 30$	23.23	-	$10^{-4}$	0.039
SBI, $\eta_{\text{Ins}} = 0.95$	23.13	281.7	5.003	0.841
SBI, $\eta_{\text{Ins}} = 0.90$	23.13	313.1	4.627	0.840
FII, $D_{\text{Ins}} = 25$	23.49	1272.0	$10^{-4}$	0.047
FII, $D_{\text{Ins}} = 50$	23.32	632.0	4.784	0.825

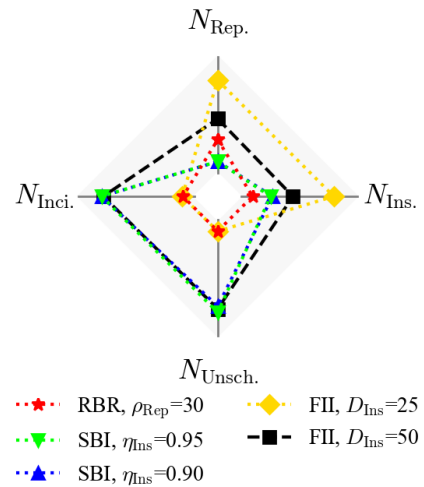

Fig. 11. Comparison of the KPIs of maintenance strategies RBR, SBR and FII in a radar chart.



the RBR strategy does not waste the useful life of the brakes, which is illustrated by the small number of brake replacements  $N_{Rep.}$  compared to the FII strategy. The SBI strategy also reduces the number of inspection tasks  $N_{Ins.}$ , compared to the baseline FII strategy. However, the number of unscheduled maintenance  $N_{Unsch.}$  and degradation incidents  $N_{Inci.}$  are similar to the baseline FII strategy. Thus, SBI is beneficial only in terms of reducing the number of inspections.

For the FII strategy with  $D_{Ins} = 25_{FCs}$ , when the inspection interval is reduced to half, the number of incidents and unscheduled maintenance is significantly reduced. However, this is achieved at the cost of performing much more inspection tasks. Although an inspection task is less expensive compared to a replacement task, it still requires the aircraft to be grounded and the mechanics have to be available to perform the inspections (Huynh et al., 2011).

In conclusion, the predictive maintenance strategy, namely the RBR strategy, dominates the baseline FII strategy ( $D_{Ins} = 50$ ) in terms of all KPIs. Moreover, this predictive strategy results in the smallest number of degradation incidents  $N_{Inci.}$  and unscheduled maintenance  $N_{Unsch.}$ . In fact,  $N_{Unsch.}$  and  $N_{Inci.}$  under the RBR strategy is similar to the case of the FII strategy with  $D_{Ins} = 25_{FCs}$ , which implies that utilizing RUL prognostics (RBR strategy) is as effective as performing two times more frequent inspections. This is achieved by utilizing the sensor data to predict the RUL of the components, instead of inspection tasks performed by mechanics. As a result, the RBR strategy is also associated with a small number of maintenance tasks.

## 6. Conclusion

In this paper, we model and analyze the performance of predictive aircraft maintenance using stochastically and dynamically colored Petri nets (SDCPNs) and Monte Carlo simulation. The SD-CPN is shown to be suitable to model and assess the complex interactions involved in the predictive aircraft maintenance process. Furthermore, the SD-CPN models of the stakeholders are easily adapted to follow various maintenance strategies and to consider various aircraft systems. Thus, we utilize this model for the assessment of both traditional and novel, predictive aircraft maintenance strategies.

A case study is carried for the maintenance of aircraft landing gear brakes with a  $k$ -out-of- $n$  redundancy. Three types of maintenance strategies are considered: a predictive maintenance strategy that relies on the analysis of health monitoring sensor-data and the estimation of the remaining-useful-life of components, and two maintenance strategies that rely on preliminary inspections to specify whether components should be replaced

or not. The result shows that the RUL-based predictive maintenance strategy considered outperforms the inspection-based maintenance strategies in terms of the number of maintenance tasks, unscheduled maintenance, and degradation incidents.

## Acknowledgement

This research has received funding from the European Union's Horizon 2020 research and innovation programme under grant agreement No 769288.

## References

- Alaswad, S. and Y. Xiang (2017). A review on condition-based maintenance optimization models for stochastically deteriorating system. *Reliability Engineering & System Safety* 157, 54–63.
- Crowder, M. and J. Lawless (2007). On a scheme for predictive maintenance. *European Journal of Operational Research* 176(3), 1713–1722.
- Huynh, K. T., A. Barros, C. Bérenguer, and I. T. Castro (2011). A periodic inspection and replacement policy for systems subject to competing failure modes due to degradation and traumatic events. *Reliability Engineering and System Safety* 96(4), 497–508.
- Lee, J. and M. Mitici (2020). An integrated assessment of safety and efficiency of aircraft maintenance strategies using agent-based modelling and stochastic Petri nets. *Reliability Engineering and System Safety* 202, 107052.
- Lee, J. and M. Mitici (2021). Multi-objective analysis of condition-based aircraft maintenance strategies using discrete event simulation. In *Reliability and Maintainability Symposium*, Orlando, FL.
- Mitici, M. and H. A. P. Blom (2019). Mathematical Models for Air Traffic Conflict and Collision Probability Estimation. *IEEE Transactions on Intelligent Transportation Systems* 20(3), 1052–1068.
- Pater, I. D. and M. Mitici (2021). Predictive maintenance for multi-component systems of repairables with Remaining-Useful-Life prognostics and a limited stock of spare components. *Reliability Engineering and System Safety* 214, 107761.
- Ran, Y., X. Zhou, P. Lin, Y. Wen, and R. Deng (2019). A survey of predictive maintenance: Systems, purposes and approaches. *arXiv*, 1–36.
- Sheng, J. and D. Prescott (2019). A coloured Petri net framework for modelling aircraft fleet maintenance. In *Reliability Engineering and System Safety*, Volume 189, pp. 67–88. Elsevier Ltd.
- van Noortwijk, J. M. (2009). A survey of the application of gamma processes in maintenance. *Reliability Engineering and System Safety* 94, 2–21.