

## Quantifying the Severity of Short-term Instability Voltage Deviations

Boricic, Aleksandar ; Rueda Torres, José Luis; Popov, Marjan

**DOI**

[10.1109/SEST53650.2022.9898503](https://doi.org/10.1109/SEST53650.2022.9898503)

**Publication date**

2022

**Document Version**

Submitted manuscript

**Published in**

Proceedings of the 2022 International Conference on Smart Energy Systems and Technologies (SEST)

**Citation (APA)**

Boricic, A., Rueda Torres, J. L., & Popov, M. (2022). Quantifying the Severity of Short-term Instability Voltage Deviations. In *Proceedings of the 2022 International Conference on Smart Energy Systems and Technologies (SEST)* (pp. 1-6). (SEST 2022 - 5th International Conference on Smart Energy Systems and Technologies). IEEE. <https://doi.org/10.1109/SEST53650.2022.9898503>

**Important note**

To cite this publication, please use the final published version (if applicable).  
Please check the document version above.

**Copyright**

Other than for strictly personal use, it is not permitted to download, forward or distribute the text or part of it, without the consent of the author(s) and/or copyright holder(s), unless the work is under an open content license such as Creative Commons.

**Takedown policy**

Please contact us and provide details if you believe this document breaches copyrights.  
We will remove access to the work immediately and investigate your claim.

# Quantifying the Severity of Short-term Instability Voltage Deviations

Aleksandar Boričić

Faculty of EEMCS

Delft University of Technology

Delft, The Netherlands

A.Boricic@tudelft.nl

Jose Luis Rueda Torres

Faculty of EEMCS

Delft University of Technology

Delft, The Netherlands

J.L.RuedaTorres@tudelft.nl

Marjan Popov

Faculty of EEMCS

Delft University of Technology

Delft, The Netherlands

M.Popov@tudelft.nl

**Abstract**— As power systems evolve from synchronous to inverter-based generation, voltage stability plays an increasingly important role. Voltage perturbations become faster and highly variable, and as such attract the research interest in the field of short-term instability monitoring and evaluation. The digitalization of the power systems provides a higher degree of observability by making use of synchrophasor measurements. The next step of utilizing such measurements by tailoring and applying innovative analytical and data-driven solutions is, however, still at the early development stage. In this paper, a novel approach that utilizes rapid post-fault voltage deviations for short-term instability quantification is investigated. The findings indicate that the approach is intuitive and effective. Finally, the paper discusses future research directions, enabled by the presented methodology, that deal with grid resilience challenges. Particularly, those related to post-disturbance system strength evaluation, as well as the real-time short-term instability evaluation and prediction, are addressed.

**Keywords**—power system stability evaluation, short-term voltage stability, inverter-based resources, system strength, synchrophasors;

## I. INTRODUCTION

Worldwide, electric power systems experience rapid and unprecedented changes that often lead to the operation closer to system stability limits. The increase in complexity is seen on both the production and the demand side. On the production side, the proliferation of Inverter-Based Resources (IBR) and Distributed Energy Resources (DER) introduces a very different post-fault response of the system, potentially jeopardizing its resilience and contributing to vulnerability [1-3]. On the demand side, the accelerating electrification and the application of converters lead to a more complex response that cannot be modelled simplistically anymore [3, 4].

This affects both system stability and grid operation [5]. Whilst the stability of the conventional power systems was fundamentally related to rotor angle performance, the stability of the IBRs, the penetration of which continuously increases, is primarily judged by the voltage performance. This is because IBRs' stable operation requires stable voltages. When a voltage experiences perturbations, it is more likely for the IBRs to disconnect, desynchronize, or fail to support the grid. As this tends to occur in already-severe voltage conditions, it may further exacerbate the situation. Additionally, the reduction of synchronous generation leads to lower system strength, which makes the evaluation and the quantification of voltage deviations and stability a very important subject [6].

Therefore, modern power systems become much more voltage-sensitive, and for a system with a high penetration of power electronics that rely on stiff voltages, short-term voltage stability is of paramount importance. In this paper, we propose how these structural system changes should also change the way we evaluate and quantify short-term stability.

To evaluate short-term instability, the current practice is to typically focus on the binary representation of (in)stability. Grid operators define relatively straightforward voltage-time thresholds, and when a voltage deviates outside of these thresholds, it is deemed unstable. For instance, in the US, the Western Electricity Coordinating Council (WECC) defines fixed thresholds depending on the type of the event [7]. In the EU, Transmission System Operators (TSOs) define instability thresholds differently, sometimes based on ride-through criteria in the grid codes [8]. Such approaches are not intended nor applicable to quantify the severity of voltage deviations.

Other advanced short-term instability methods typically focus on monitoring instability-specific metrics such as rotor angles [9], load admittances [10], or frequency and damping of oscillations [11]. Alternatively, [12] evaluates the transient IBR stability using Lyapunov's method, while [13] reviews several stability methods and challenges in IBR-rich grids.

In this paper, the problem is analysed from a very different perspective. By evaluating post-fault voltage deviations directly through a novel and unified approach, it is shown how the severity of various short-term instabilities can be quantified. In this way, an insight into the risks of cascading and consequent instability of various types can be provided.

The paper is organized as follows. Section II provides a background on the relevant short-term instability mechanisms and how they evolve and interact as the IBR penetration increases. Section III introduces a novel method for the real-time evaluation and quantification of instabilities presented in Section II. In Section IV, the test setup is elaborated, followed by a comprehensive analysis and discussion. Finally, Section V concludes the paper and discusses future research possibilities that are enabled by the newly introduced method.

## II. SHORT-TERM INSTABILITY PHENOMENA IN MODERN POWER SYSTEMS

For conventional power systems, short-term instability was mainly understood as either Short-Term Voltage Instability (STVI), or Transient Rotor Angle Instability (TRAI) [14]. The former is commonly a consequence of post-fault loss of equilibrium in load-to-system interactions, particularly dynamic loads. A possible disturbance causes motors deceleration, and in certain cases, instability may occur, characterized by a rapid voltage collapse. Prior to the potential collapse, oscillations may also occur as a consequence of interactions between the dynamic load restoration and synchronous generators' (SG) voltage regulators. Therefore, to appropriately analyse STVI, a detailed representation of dynamic loads is needed. The onset of STVI typically occurs after a fault in areas with a high share of (dynamic) load. The instability can be also related to HVDC dynamics, and more recently, IBR and/or DER dynamics [2].

TRAI, on the other hand, is a generator-related event. A disturbance, typically short-circuit in tie-lines and/or near

synchronous generators, could cause the rotor angles of the generators (or generator groups) to drift too far from each other, effectively losing synchronism. The instability can be either a first swing instability or after a few cycles of oscillations. The latter is more common for larger systems with many SGs. The usual frequency range of these electromechanical oscillations is up to 2.5Hz, depending on the size and the number of SGs involved [2].

These two forms of instability, STVI and TRAI, are still present in modern systems, but they become intertwined with new IBRs and load dynamics. Therefore, to describe the short-term stability of modern systems, new subtypes of short-term instability are emerging [2].

One of them is the Fault-Induced Delayed Voltage Recovery (FIDVR). FIDVR is characterized as a post-fault depressed voltage, lasting typically from several seconds up to tens of seconds, jeopardizing the overall system's ability to recover. This is mainly attributed to stalling of large amounts of induction motors, particularly the A/C units [15]. After the stalled motors get disconnected by the overcurrent or thermal protection, an overvoltage situation may arise. FIDVR is not an instability on its own, as the system may succeed to recover in some cases, but the voltage consequences of FIDVR present a major threat to cascading. Conceptually, FIDVR can be also described as a less severe specific type of STVI, as it is fundamentally related to motor stalling. Furthermore, FIDVR can be affected and possibly exacerbated by DER operation, particularly inverter blocking or disconnection [3, 16].

Another newly introduced form of short-term instability is converter-driven instability. It can manifest itself in terms of fast interactions (hundreds of Hz), and slow interactions (typically around 10Hz or less) [2]. The latter, Converter-driven Slow-Interactions Instability (CSII), is further considered in this paper, while the former is out of scope. CSII usually emerges in “weak” system sections, where voltage is very sensitive to changes in active and reactive current/power. After a disturbance, the inverter controls may not be able to “lock” onto grid voltages correctly, resulting in voltage oscillations. Additionally, as more inverters are introduced in the systems, there is more chance of undesired interactions, sometimes leading to oscillatory behaviour and possible voltage collapse if undamped. The post-fault converter-related

instabilities have been an increasingly relevant subject worldwide, particularly (but not exclusively) in the systems with already high (local) IBR penetration and with consequent system strength reduction, such as in Australia, Texas, California, China, or the United Kingdom [17].

The four described phenomena (STVI, TRAI, FIDVR, and CSII) are concisely described in Fig 1. All four phenomena are distinctive in the location where they typically emerge, the origin of instability, the way of manifesting itself, and ultimately the control actions that can be taken to prevent them. However, they also have many common characteristics:

- Manifestation in a similar time scale (usually <10s),
- All of them lead to significantly disturbed (but distinctive) post-fault voltage deviations,
- They often interact with each other when a potential system instability takes place,
- They become more common and more severe due to the introduction of more inverter-based resources and reduction of system strength,
- May lead to cascading events and system blackouts.

As the instability phenomena become more entangled, the risks of cascading increase accordingly [2-3]. However, the present experience typically focuses on analysing, quantifying, and predicting them individually. This may not be optimal considering intertwined voltage dynamics seen more commonly in modern power systems, which will be exemplified in Section IV. The quantification of various types of short-term instabilities is not only preferred but also necessary to preserve the stability of renewables-driven power grids in various operational scenarios. Before any smart preventive and corrective strategies can be introduced, the effects should be quantified and accurately predicted.

In this paper, this is addressed by focusing on a voltage-based method of quantifying post-fault short-term instabilities – the cumulative voltage deviation (CVD) metric. Such an approach is novel as it is applicable and relevant for all short-term instability mechanisms, even in grids with a high penetration of IBRs and dynamic loads. The applied method is described in Section III and tested by utilizing dynamic simulations in Section IV.

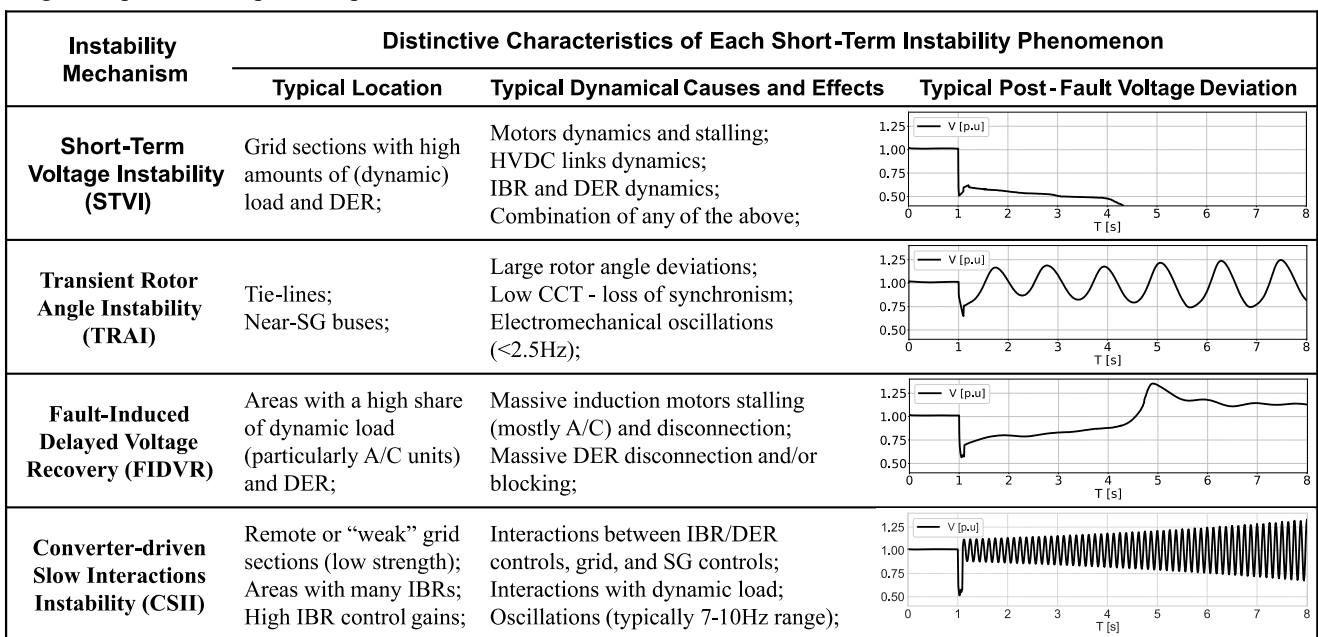

Fig 1. A concise overview of the four distinctive short-term instability phenomena, their characteristics, and illustrative post-fault voltage deviations.

### III. METHODOLOGY

Evaluating short-term instabilities has been a research topic for many years, although the field is still immature in comparison to the long-term stability evaluation [18]. As electrical power systems experience lower inertia and lower system strength, system dynamics inevitably accelerate. Furthermore, as described in Section II, IBR-dominated grids are voltage-sensitive. Therefore, evaluating and quantifying short-term voltage deviations becomes much more relevant.

Concurrently, the availability of Phasor Measurement Units (PMUs) drastically changes the real-time monitoring and control landscape [19]. What used to be impossible due to the slow SCADA sampling (typically one unsynchronized measurement per 1-3 seconds), is now much more feasible with time-synchronized and fast wide-area measurements (typically fifty or more measurements per second). This opens a completely new range of possibilities in monitoring and vulnerability assessment analysis in modern power systems.

There are, nonetheless, some available methods that deal with short-term instability evaluation. We omit a detailed overview for brevity and refer readers to [20] and [18], where the most common methods have been analysed, including their shortcomings when applied to modern power systems.

Some of the conclusions were that a new quantitative metric is necessary for IBR-rich systems, which can achieve the following:

- Able to detect and quantify the severity of various post-fault short-term voltage deviations,
- Useful in both conventional and converter-dominated systems,
- Intuitive for practical on- and off-line applications,
- Adaptable to any system and operational scenario,
- As simple and computationally efficient as possible,
- Can provide real-time insights into post-fault stability, for instance by relying on PMU data.

To address these challenges, this paper introduces the Cumulative Voltage Deviation (CVD) method, visualized in Fig. 2. and mathematically described by (1), (2), and (3).

$$V_U(t) = (1 + a)V_0 - t/b \quad (1)$$

$$V_D(t) = (1 - a)V_0 + t/b \quad (2)$$

$$CVD = \sum_{t=t_f}^{t=t_f+T} \begin{cases} V(t) - V_U(t), & \text{if } V(t) > V_U(t) \\ V_D(t) - V(t), & \text{if } V(t) < V_D(t) \\ 0, & \text{else} \end{cases} \quad (3)$$

In (3),  $t_f$  is the fault inception time, and  $T$  is the evaluation time window.  $V_U(t)$  is the up threshold (blue dashed line in the upper graph in Fig. 2), whereas  $V_D(t)$  is the down threshold (the orange dashed line of the lower graph in Fig. 2).

The CVD evaluation starts once the voltage overshoots the initial threshold (shown as points A or C in Fig. 2), indicating a disturbance that may potentially lead to instability. The linear envelope threshold is then applied to quantify the severity and duration of the detected voltage deviations. Based on this threshold, the post-disturbance voltage deviations are disentangled into undervoltages (orange in Fig. 2) and overvoltages (blue in Fig. 2), and extracted onto a voltage deviation chart (the lower plot of Fig. 2). The green line of the lower plot represents CVD, i.e. the cumulative sum of over- (blue) and undervoltage (orange) deviations. Therefore, the

final CVD value reflects the total amplitude and the time of the voltage deviations outside the predefined limits.

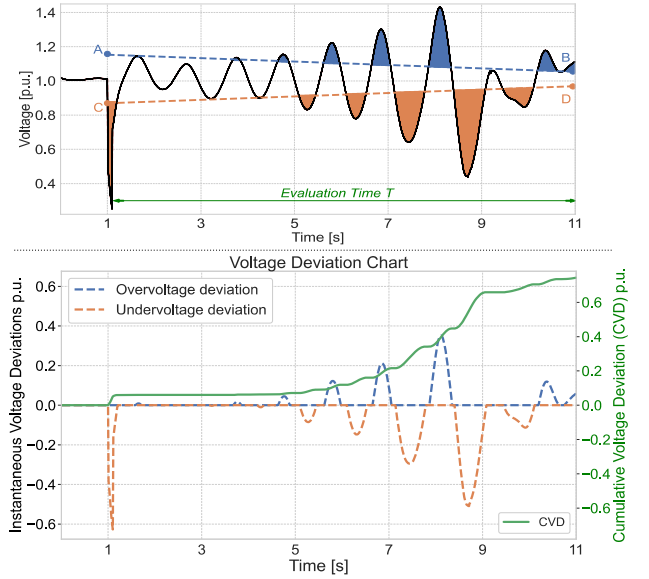

Fig. 2. Visualization of the CVD method for an illustrative case of voltage oscillations related to post-fault TRAI.

The linear threshold is chosen as it exploits the fact that voltage deviations in the late (early) post-disturbance phase are more (less) indicative of instabilities. In other words, initial large post-fault voltage transients are to be expected, however, when the voltage deviations do not decrease sufficiently fast during the post-fault period, it indicates a larger probability of instability. Furthermore, the method is straightforward, computationally fast, and valid for any system or short-term instability scenario addressed in Fig. 1, which will be shown in Section IV. Finally, as it relies solely on voltage measurements, it is applicable for not just offline, but also online studies, by utilizing PMU measurements.

A short-term instability monitoring method should be easy to parametrize and apply to various systems [20]. The CVD method requires the setting of only three simple parameters. The first is the evaluation time denoted with  $T$ . As described in Section II, the majority of the phenomena in question occur within a ten seconds time frame, therefore chosen as a  $T$  value. Such a value is also commonly used for short-term studies [2]. The other two parameters are  $a$  and  $b$ . They define the initial points (A and C in Fig. 2), and the final points (B and D in Fig. 2), including the slopes of  $V_U(t)$  and  $V_D(t)$ . To detect and quantify severe voltage deviations of the four types introduced in Section II, we propose  $a = 0.15$  and  $b = 100$ . Practically, this means that the evaluation starts when the voltage overshoots  $\pm 15\%$  from the pre-fault voltage ( $t \approx t_f$ ), moving towards  $\pm 5\%$  ( $t = t_f + T$ ), with a slope of  $1\%/s$ . Such values are chosen as they represent common thresholds for large voltage disturbances and recovery values, respectively, and at the same time efficiently capture various short-term phenomena, as highlighted in Section IV. Finally,  $V_0$  is the pre-fault voltage, which can be calculated as an average value prior to the fault. To ensure that the pre-fault voltage value is not impacted by the fault transients or initial model transients, a half-a-second pre-fault window  $[0.4s - 0.9s]$  is used.

The effectiveness and the applicability of CVD in detecting and quantifying the severity of various short-term voltage deviations with the selected parameters are further analysed in Section IV.

#### IV. RESULTS AND DISCUSSION

In this section, the efficacy of the CVD is evaluated on a large number of dynamic simulations utilizing DiGSILENT PowerFactory supported by Python scripting [21]. The CVD method is assessed for various instability phenomena described in Section II and compared to an existing commonly used metric for quantification of voltage deviations [20].

To obtain a relevant analysis and comparison, a large number of dynamic post-fault voltage curves is needed. For this task, IEEE Test System for Voltage Stability Analysis and Security Assessment is used [22]. This test grid is currently one of the most advanced grids for dynamic voltage stability simulations and is extensively used in research on related topics. The system is further enhanced by introducing a large number of WECC Composite Load models, necessary to improve the accuracy of grid and load dynamics [3, 23]. The model is depicted in Fig. 3.

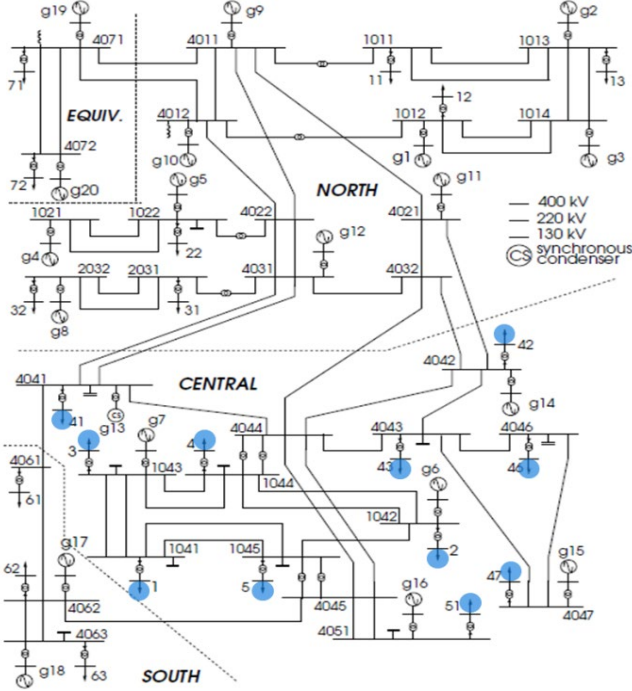

Fig. 3 IEEE Test System for Voltage Stability Analysis and Security Assessment, with blue circles indicating WECC composite load additions. See [22] and [3] for more details about the test grid and selected scenarios.

All the simulations are performed for 100ms three-phase faults in bus 4044 with a fault impedance of  $2.5\Omega$  unless stated differently. A large number of scenarios are selected based on the analysis conducted in [3], which demonstrated the system conditions and parameters that lead to relevant instabilities in this grid. The voltage responses are reported for bus 1041, with comparable results to other buses susceptible to voltage instability in the central area [3, 22].

The CVD method, as per parameters from Section III, is compared to the Transient Voltage Severity Index (TVSI), which is commonly used in the literature for quantifying post-fault transient voltage deviations [24]. The TVSI method for a specific bus is mathematically straightforward and is described in (4) and (5),

$$TVSI = \frac{\sum_{t=T_c}^T TVDI_{i,t}}{(T-T_c)} \quad (4)$$

$$TVDI = \begin{cases} \frac{|V_{i,t} - V_{i,0}|}{V_{i,0}}, & \text{if } \frac{|V_{i,t} - V_{i,0}|}{V_{i,0}} \geq \mu \quad \forall t \in [T_c, T] \\ 0, & \text{otherwise} \end{cases} \quad (5)$$

where  $T$  is the analysed transient time frame,  $T_c$  is the fault clearing time, TVDI is the Transient Voltage Deviation Index,  $V_{i,t}$  is the voltage magnitude of the bus  $i$  at time  $t$ , and  $\mu$  is the threshold used to define unacceptable voltage deviation level. According to [24], a threshold of  $\mu = 20\%$  is adopted for the analysis and comparison purposes. Further information on the method can be found in [20, 24].

##### A. Fault-Induced Delayed Voltage Recovery (FIDVR)

The analysis begins with FIDVR simulations. The best way to simulate FIDVR events is to introduce a large number of stalling-prone dynamic loads, particularly single-phase A/C units. The more loads, the more severe the FIDVR event is. With that in mind, a range of 25 dynamic simulations is conducted with increasing severity, by controlling two parameters: (i) the overall dynamic load percentage in the grid; and (ii) the percentage of motor type D (single-phase A/C units) in the WECC composite loads. The simulations with varying parameters are shown in Table I.

TABLE I. PARAMETERS USED TO MODEL FIDVR EVENTS

Simulation number	Dynamic Load Penetration [%]	Share of motor type D [%]
0	16%	36%
1	17%	37%
2	18%	38%
...	...	...
24	40%	60%

The share of A/B/C-type motors in the dynamic loads is set to 0.1 for all simulations to replicate realistically diverse system loads, based on the methodology reported in [3].

The results are shown in two leftmost plots in Fig. 4. The upper left graph shows the increasingly severe FIDVR voltage events, with darker colour indicating a more severe scenario. The corresponding CVD and TVSI thresholds are also depicted. The lower left graph shows a scatterplot that quantifies the total severity events (normalized to event 0), for CVD and TVSI. The events are reported on the x-axis from the least severe (leftmost, simulation number 0), to the most severe (rightmost, simulation number 24), as per Table I.

What can be seen is that TVSI reaches a peak at event number 12, inaccurately indicating that following events are less (not more) severe. Meanwhile, CVD successfully quantifies the increasing severity, presenting a linear rise. This can be explained by a few key differences between the two approaches: (i) TVSI is, unlike CVD, unable to take into account the time-increasing voltage characteristics of FIDVR; (ii) the overvoltage deviations in the late FIDVR phase, which can be detrimental to the system's ability to recover, are much better evaluated by CVD; and (iii) CVD threshold depends on the pre-fault voltage, unlike TVSI, which helps in adapting the linear thresholds more accurately to the specific event.

Overall, it can be concluded that FIDVR events of increasing severities are adequately quantified by the CVD approach, which shows much better performance than TVSI.

##### B. Converter-driven Slow Interactions Instability (CSII)

To model increasingly severe CSII events, electromagnetic transient (EMT) simulations would be necessary, as any RMS-modelled events above  $\sim 5\text{Hz}$  are unlikely to be accurate enough [25]. Furthermore, realistic CSII voltage deviations are generally difficult to model, as they are a consequence of complex control interactions. As RMS simulations on the system from Fig. 3 are performed in



this paper, a different approach of deriving suitable voltage profiles is used. Relying on the current understanding of CSII phenomena [2], and according to the recent CSII events from Texas, Australia, and Scotland [17], synthetic events are created analytically, with post-clearing voltage defined by (6).

$$V(t) = Ae^{\beta t} \cos(2\pi ft) + 1 \quad ; \quad \text{for } t > t_{cl} \quad (6)$$

The two parameters, initial amplitude  $A$  and exponential coefficient  $\beta$ , are defined in a range of values, as shown in Table II. The values are chosen to replicate expected CSII as accurately as possible based on real grid events [17], while at the same time providing increasing severity in terms of amplitude and exponential rise in the post-fault period.

TABLE II. PARAMETERS USED TO MODEL CSII EVENTS

Simulation number	Amplitude $A$	Exponential coefficient $\beta$
0	0.052	0.05
1	0.054	0.054
2	0.056	0.058
...	...	...
24	0.100	0.150

The derived voltages are shown in the upper middle plot of Fig. 4. The synthetic voltage profiles match very well with the ones seen in EMT analyses or field measurements [6, 17]. The least severe voltage profile is plotted in dashed red for clearer visualization, whereas every following event has a higher amplitude and exponential rise, as shown in Table II.

In the lower middle scatterplot, the quantification of these events is shown for CVD and TVSI. Starting with TVSI, one can see that the increasing severity is accurately quantified only from event number 13. Before this event, the sensitivity of TVSI is insufficient to differentiate among the events of various severities. On the other hand, CVD is sensitive enough to pick up the differences even amongst the first few events and continues to quantify increasing severity for all the events. These improvements in CVD relative to TVSI are, similar to FIDVR, a consequence of analogous reasons as with FIDVR. Furthermore, the ability to put more weight on voltage deviations further from the fault clearing benefits CVD over TVSI, which shows to be very important in exponentially growing oscillatory behaviour.

The frequency of the oscillations  $f$  is chosen to be 8Hz, as the frequency range of CSII is typically 7 - 10Hz [6, 17]. The results are not sensitive to this assumption and hold equally for other CSII event frequencies. This is analysed but unreported in the paper for brevity. From the overall results, it

can be seen that CVD is very suitable for quantifying the severity of CSII-related post-fault voltage deviations.

### C. Combined Instability (FIDVR + TRAI)

For the final round of presented simulations, a case of intertwined instabilities is considered. As discussed in Section II, the structural changes of the power systems lead to more interactions among different instability phenomena, resulting in a risk of cascading instabilities, which is illustrated here.

The simulations in this subsection are, once again, performed on the IEEE test system from Fig. 3. To produce cases of entangled instabilities, two changes are introduced in the model: (i) a high and increasing amount of dynamic load is added; and (ii) an increased fault clearing time. Table III shows the events taken into consideration.

TABLE III. PARAMETERS USED TO MODEL COMBINED INSTABILITY EVENTS

Simulation number	Dynamic load penetration [%]	Fault clearing time (100ms default) [ms]
0	38%	125 ms
1	38.5%	125 ms
2	39%	125 ms
...	...	...
24	50%	125 ms

The share of A/B/C/D-type motors in the dynamic loads is set to 0.1/0.1/0.3/0.1, respectively, for all simulations, which is in line with the methodology reported in [3]. The values are chosen in a way to produce the combined instability scenarios.

The results are shown in the rightmost plots in Fig. 4. All the events show an initial short-lasting FIDVR event (up to ~3-4 seconds), followed by electromechanical oscillations which indicate a risk of TRAI. The simulations are sorted in an increasing severity order, as shown in Table III. This can be seen in the increasingly severe FIDVR, as well as stronger voltage oscillations, starting from the least severe case (dashed red). Such complex grid instability phenomena are more likely to emerge in modern grids, as discussed in Section II, for instance in low inertia grids with a high share of dynamic load.

From the rightmost lower scatterplot, again one can note that CVD is performing much better than TVSI in quantifying the severity of these voltage deviations. TVSI shows almost no sensitivity to the increasing severity up to event number 20, which is already a very severe one. The last five events are the most severe as TRAI rapidly unfolds, followed by low-frequency but extremely high-amplitude voltage deviations that are followed by out-of-step conditions and potential

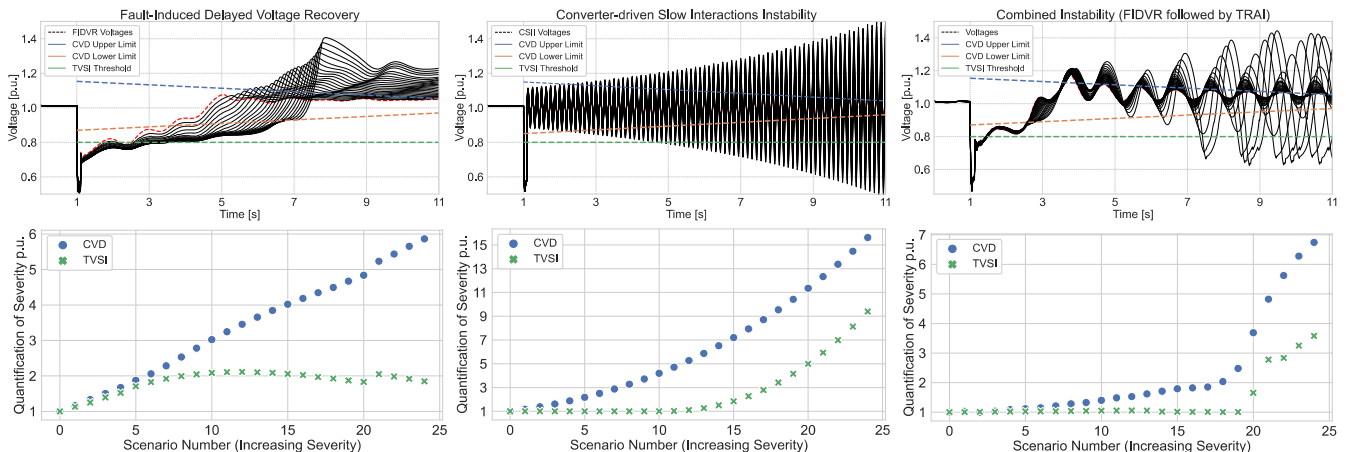

Fig 4. Comparison simulations of CVD and TVSI methods; Upper graph plots all dynamic simulations (black) with increasing severity (red dashed line is the least severe). The scatterplots show corresponding quantification (normalized) of voltage deviations of CVD (blue circles) and TVSI (green crosses).

system instability. CVD is again able to correctly distinguish between various events of different severity by utilizing time-adaptive linear voltage thresholds.

The results from the three analysed instability mechanisms show unanimously how a cumulative voltage deviation is an efficient approach to quantify post-voltage deviations. The method performs notably better than the current commonly used severity index TVSI, with much less risk of underestimating an event, irrespective of the instability type.

## V. CONCLUSIONS AND FURTHER RESEARCH

This paper explores how the structural changes that power systems experience with the proliferation of IBRs affect stability evaluations. As systems inevitably become weaker with the higher IBR penetrations, the voltage deviations (especially short-term) play a larger role in understanding, describing, and evaluating instabilities. The presently available short-term stability evaluation methods, however, are facing three main challenges. Firstly, they are rarely applicable to modern power systems with a high penetration of IBRs and dynamic loads. Secondly, they usually focus on a single phenomenon, despite instabilities becoming more intertwined. Lastly, they typically offer a binary instability representation, without the quantification of event severity.

In this paper, a novel voltage-based method is proposed to mitigate these challenges. By focusing on voltage deviations, the method becomes more applicable to converter-rich systems and various conventional and emerging instability phenomena, including combined instability events. Furthermore, the method is able to quantify how severe a certain grid event is, which offers much more insight than a simple binary stability output. The efficacy and applicability of the method are evaluated on a large number of diverse dynamic simulations and instabilities, demonstrating noteworthy improvements compared to available methods.

In terms of further research, the ability to quantify the severity of post-fault voltage deviations enables several promising future applications. Firstly, for offline studies, it is possible to quantify how dangerous certain operating scenarios are for any grid section, providing information on system strength and resilience. This can be accomplished by performing a large number of dynamic simulations with advanced IBR and dynamic load models, followed by statistical CVD-based regression analysis. Such an approach shall be investigated in the authors' follow-up work.

Secondly, for real-time assessment, specific patterns of various instabilities can be evaluated through the CVD method. Each instability mechanism has a specific under- and overvoltage pattern (see Fig. 1), which can be extracted from the CVD evaluation and used to swiftly detect instability and its type. Moreover, this can be further improved by combining CVD measurements with other phenomenon-specific variables of interest that can be effectively measured via synchrophasors. This, as well, is a topic of further research. By being able to detect and quantify instability risks in real-time, suitable preventive and/or corrective measures can be taken to preserve system resilience and avoid cascading.

## ACKNOWLEDGMENT

This work was financially supported by the Dutch Scientific Council NWO in collaboration with TSO TenneT, DSOs Alliander, Stedin, Enduris, VSL and General Electric in the framework of the Energy System Integration & Big Data program under the project "Resilient Synchro-measurement-based Grid Protection Platform, no. 647.003.004".

## VI. REFERENCES

- [1] IEEE PES-TR68, "Impact of Inverter Based Generation on Bulk Power System Dynamics and Short-Circuit Performance", July 2018.
- [2] IEEE PES-TR77, "Stability definitions and characterization of dynamic behavior in systems with high penetration of power electronic interfaced technologies", April 2020.
- [3] A. Boričić, J. L. R. Torres, M. Popov, "Fundamental Study on the Influence of Dynamic Load and Distributed Energy Resources on Power System Short-Term Voltage Stability", *International Journal of Electrical Power & Energy Systems*, 2021.
- [4] A. Arif, Z. Wang, J. Wang, et al. "Load Modeling—A Review," *IEEE Transactions on Smart Grid*, Nov. 2018.
- [5] J. Matevosyan et al. "A Future With Inverter-Based Resources: Finding Strength From Traditional Weakness," in *IEEE Power and Energy Magazine*, vol. 19, no. 6, pp. 18-28, Nov.-Dec. 2021.
- [6] B. Badrzadeh, Z. Emin, S. Goyal, et al. "System Strength", *CIGRE Science&Engineering Journal*, Volume No.20, Feb. 2021.
- [7] WECC Criterion TPL-001-WECC-CRT-3.2 "Transmission System Planning Performance", 2019.
- [8] ENTSO-E, "Parameters related to voltage issues", ENTSO-E guidance document for national implementation for network codes on grid connection, Nov. 2016.
- [9] S. A. Siddiqui, K. Verma, K. R. Niazi and M. Fozdar, "Real-Time Monitoring of Post-Fault Scenario for Determining Generator Coherency and Transient Stability Through ANN," *IEEE Transactions on Industry Applications*, 2017.
- [10] A. R. R. Matavalam, V. Ajarapu, "PMU-Based Monitoring and Mitigation of Delayed Voltage Recovery Using Admittances," *IEEE Transactions on Power Systems*, 2019.
- [11] M. Golshani, D. Wilson, S. Norris, et al. "Application of phasor-based functionality to HVDC control in reduced system strength," *The 17th International Conference on AC and DC Power Transmission*, 2021.
- [12] M. Z. Mansour, S. P. Me, S. Hadavi, et al. "Nonlinear Transient Stability Analysis of Phased-Locked Loop-Based Grid-Following Voltage-Source Converters Using Lyapunov's Direct Method," *IEEE Journal of Emerging and Selected Topics in Power Electronics*, 2022
- [13] R. W. Kenyon, M. Bossart, M. Marković, et al. "Stability and control of power systems with high penetrations of inverter-based resources: An accessible review of current knowledge and open questions", *Solar Energy*, 2020
- [14] T. V. Cutsem, C. Vournas, "Voltage Stability of Electric Power Systems", *Springer* 1998.
- [15] S. Adhikari, J. Schoene, N. Gurung and A. Mogilevsky, "Fault Induced Delayed Voltage Recovery (FIDVR): Modeling and Guidelines," *IEEE PES General Meeting*, 2019.
- [16] R. Venkatraman, S. K. Khaitan, V. Ajarapu, "Impact of Distribution Generation Penetration on Power System Dynamics considering Ride-Through Requirements," *IEEE PES General Meeting*, 2018.
- [17] Y. Cheng L. Fan, J. Rose, et al. "Real-World Subsynchronous Oscillation Events in Power Grids with High Penetrations of Inverter-Based Resources", *IEEE Transactions on Power Systems*, 2022
- [18] M. Glavic, T. Van Cutsem, "A short survey of methods for voltage instability detection," *IEEE PES General Meeting*, 2011.
- [19] F. R. S. Sevilla et al., "State-of-the-art of data collection, analytics, and future needs of transmission utilities worldwide to account for the continuous growth of sensing data", *International Journal of Electrical Power & Energy Systems*, 2022
- [20] A. Boričić, J. L. R. Torres, M. Popov, "Comprehensive Review of Short-Term Voltage Stability Evaluation Methods in Modern Power Systems", *Energies*, 2021.
- [21] F. M. Gonzalez-Longatt, J. L. R. Torres. "Advanced Smart Grid Functionalities Based on PowerFactory". *Springer* 2018.
- [22] T. V. Cutsem, M. Glavic, W. Rosehart, et al. "Test Systems for Voltage Stability Studies". *IEEE Transactions on Power Systems*, 2020.
- [23] A. Boričić, J. L. R. Torres, M. Popov, "Impact of Modelling Assumptions on the Voltage Stability Assessment of Active Distribution Grids," *IEEE PES ISGT Europe*, 2020.
- [24] Y. Xu, Z. Y. Dong, K. Meng, et al. "Multi-Objective Dynamic VAR Planning Against Short-Term Voltage Instability Using a Decomposition-Based Evolutionary Algorithm," *IEEE Transactions on Power Systems*, Nov. 2014.
- [25] CIGRE WG B4.62 671, "Connection of wind farms to weak AC networks", CIGRE Technical Report, 2016