

Innovative system for the construction and management of student residences - Frameup system

De Andrade, Pedro Pimenta; Lagerqvist, Ove; Veljkovic, Milan; Simoes, Rui; Lundholm, John

Publication date

2016

Document Version

Final published version

Published in

IABSE Congress Stockholm, 2016: Challenges in Design and Construction of an Innovative and Sustainable Built Environment

Citation (APA)

De Andrade, P. P., Lagerqvist, O., Veljkovic, M., Simoes, R., & Lundholm, J. (2016). Innovative system for the construction and management of student residences - Frameup system. In *IABSE Congress Stockholm, 2016: Challenges in Design and Construction of an Innovative and Sustainable Built Environment* (pp. 1364-1370). International Association for Bridge and Structural Engineering (IABSE).

Important note

To cite this publication, please use the final published version (if applicable). Please check the document version above.

Copyright

Other than for strictly personal use, it is not permitted to download, forward or distribute the text or part of it, without the consent of the author(s) and/or copyright holder(s), unless the work is under an open content license such as Creative Commons.

Takedown policy

Please contact us and provide details if you believe this document breaches copyrights. We will remove access to the work immediately and investigate your claim.



INNOVATIVE SYSTEM FOR THE CONSTRUCTION AND MANAGEMENT OF STUDENT RESIDENCES – FRAMEUP SYSTEM

Pedro Pimenta de Andrade, Ove Lagerqvist

Luleå University of Technology, Luleå, Sweden

Milan Veljkovic

Delft University of Technology, Delft, Netherlands

Rui Simões

University of Coimbra, Coimbra, Portugal

John Lundholm

Part Construction AB, Kalix, Sweden

Contact: pedro.andrade@ltu.se

Abstract

Sweden has a strong demand on the construction of student accommodations and consequently significant efforts have been taken to increase and streamline construction methods so to provide on the short run, housing for students. In addition, the fluctuation on the number of students admitted at each year, in each university, leads to periods of house shortage or, in opposition to that, to eventual surplus on the housing market. For these reasons, urges finding a fast execution process in construction to fulfil the market needs, in first place, and followed up by a smart mechanism of housing management, able to cope with available housing at each time and place, so to fulfil needs of housing for each and every student. The FRAMEUP [1] system consists on the combination of modular construction - with prefabricated 3D modules (fully equipped and suitable for student accommodations) assembled on a steel frame - with an innovative system, where building is erected from the roof to its 1st floor. The existence of a lifting system permits the erection of the building, promoting each time the building is lifted, a clearance of one floor height, at ground level, for the assembly of a new floor. The procedure is repeated until the 1st floor of the building - the last floor of the execution sequence - is assembled. Alongside with its fast execution, the FRAMEUP system allows for an efficiently increase or decrease on the number of the floors, creating thus the conditions for inter permutability of modules between buildings of the same nature. Thus, assuming a net of these buildings at each university, are created the necessary conditions for exchanging of floors, so that the number of floors at each campus would follow the fluctuations of the students' population among the different universities, on different periods of time, so to suppress the housing shortage or to avoid its surplus.

Keywords: Modular construction, innovative construction system, fast construction

1 Introduction

All the present investigation has Luleå and the Swedish construction market as reference for the study. This paper introduces the facts which triggered the development of the innovative construction of student residences, where the need for time and costs savings in construction has its focus.

Labour costs generally represent a big share of the final building costs. Sweden, with an hourly rate of 24.50 €, represents the country with highest cost across EU28 [2]. Reduction in costs may be achieved by decreasing the direct costs, such as: land, labour, material and equipment. In this sense the measures towards the reduction of the labour costs, as for instances, those which streamline the construction process, have significant impact on the final cost. Simultaneously, the integration of modular construction into the construction process reveals to be much more convenient since there is no need to store materials and waste on the construction site, increases the quality of the components while it allows for a more reliability over timeframe.

Regarding student housing in Sweden, a report - *Bostadsrapport 2013* [3] - highlights the big demand for dwellings due to housing shortage. It states that only 4 out of 32 cities in Sweden can really guarantee all students dwellings within 30 days. Cities where residences cannot be offered accommodation within the falls semester are: Gothenburg, Linköping, Lund, Malmö, Stockholm, Umeå, Uppsala and Luleå, representing major cities in Sweden. More particularly in Luleå, the increase on the student population has aggravated very much the problem, and so, according to the Student residential services - *Studentbostadsservice* [3] -, around one thousand students wait to get accommodations. Students live in subsidized hostels and camping cottages, meaning that not all conditions are met for an effective study environment, therefore urges to find solutions to invert this situation.

In terms of climate, though most of Sweden exhibits a temperate climate, the northernmost part is defined as subarctic climate. The most

common practice is to schedule more sensitive tasks to coincide with a period which is more convenient for construction, however, that is not always possible to do so. As there is a demand to reduce vulnerability of construction investment, companies adopt different solutions to minimize impacts. Fig.1 shows a clear example of the investment required in order to face the weather constrains where an overall protection follows the building construction along building height and time.



Figure 1. Overall protection of construction site (Sunderby hospital, Sweden, 2013)

The innovative construction method is developed upon the aspects and conjuncture de-scribed.

2 FRAMEUP Concept

2.1 Introduction

The Frameup concept introduces a new approach in terms of execution technique which consists of the execution of a building starting from the roof to the 1st floor. The existence of a lifting system constituted of a horizontal rigid frame - grid - in combination with lifting towers - pylons - permits the erection of the building, promoting each time the building is lifted, a clearance of one-floor-height plus tolerances at the ground level. This creates room enough for the assembly of the lower floor from below the previously assembled floor. The procedure is repeated several times, according to the number of floors, until the 1st floor of the building, the last floor of the execution sequence, is assembled.

2.2 Step-by-step execution process

The Fig. 2 and Fig.3 introduce a stepwise procedure of the Frameup system in a conceptual development method, where, for the sake of visualization, the façade is neglected. First, the Lifting system is assembled and correctly aligned with the construction axes of the building (a) (see Fig. 2). The roof and the elements attached to it are installed (b) and once finished, the roof is lifted up one-storey-height plus the necessary tolerances (c). The structure, 3D modules, claddings, utilities, etc. benefit from being assembled at the ground level as they are protected from climate constraints (d). Once ready, the grid descends until the column-splices from roof and floor can be connected (e). The rigid frame is released from the structure, returning to its initial position (f), permitting erection of the structure and the subsequent assembly of the next new floor.

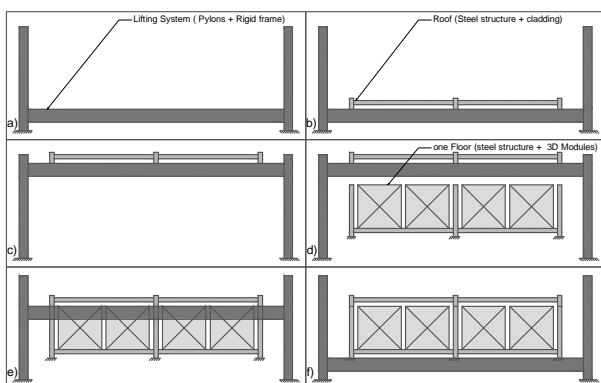

Figure 2. Six first stages of the Frameup concept [4]

The Lifting system initiates its ascension (g) (see Fig. 3) for assembly of the floor below (h), and, once ready, connects it to the building structure (i) so the process moves to next step (j).

The assembling of the floor should include all the elements which constitute it, such as: claddings, services and all kinds of installations. However, some internal tasks (i.e., service connections and finishes) may be later on completed from inside the building. Once the building construction is finished, the Lifting system is disassembled and may be reassembled for the construction/reconstruction of other buildings. Thus, it may be considered as a “construction equipment”.

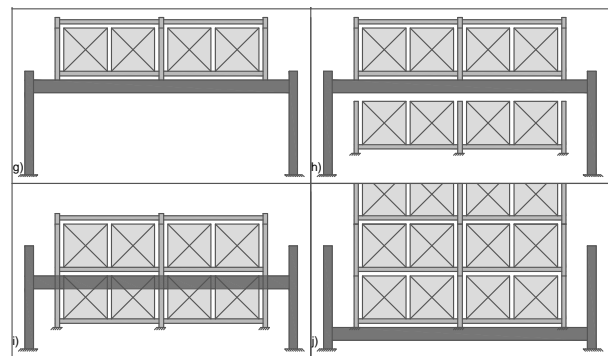

Figure 3. Four stages of the FRAMEUP concept [4]

3 Frameup components

3.1 Modular building

The student residence considered in this study is a six-story building where 3D modules are intended to provide accommodations for students. The building structure has a height of 21 m (3.2 m per floor), is 11.6 m long and 10.8 m wide; leading to a gross area of 125.3 m² (see Figure 4).



Figure 4. Conceptual view neglecting façade (left side) and with façade (right side) [4]

The structure is composed of semicontinuous three-dimensional frames modelled in a grid of 11.1 m x 10.3 m, with two bays of 5.4 m along the length and three bays of 3.8 m, 2.3 m and 3.832 m along the width. A total height of 20.337 m, 3.203 m per floor, from top-of-steel to top-of-steel, and 1.190 m height of the structure of the roof. Fig. 4 illustrates a conceptual representation of the 3D modules within the steel structure of SHS 250x10 columns and RHS 250x150x8 beams.

The eight 3D modules per floor resting on the beams have no contribution to the structural

performance of the building, which allow them to be taken directly from the structure by a forklift and to be replaced by new or refurbished 3D modules. Moreover, the number of stories can easily be adapted if desired in order to increase or decrease the number of floors. Thus, the Lifting system just needs to be reinstated in place.

The uniform members are hot-rolled structural steel, square and rectangular hollow sections, and of steel grade S355. Hollow sections reveal excellent performance with regard to loading in compression, torsion and bending, which is rather convenient for the present structure. The building is designed without a bracing system since that was seen as the suitable choice to accommodate the 3D modules, providing clear access from the façade to specific modules, in the eventual need for its replacement, while it enables the existence of large windows without constraints. This design option forced the development of joints with

enough strength and stiffness to fulfill this requirement.

3.2 Lifting System

The Lifting system constitutes the structure and the mechanisms which perform the erection of the Frameup building. Therefore, the structural analysis of the Lifting system should be performed on the basis of its actions during the execution. Within the execution process, the Lifting system should be able to keep its structural integrity for further reuse during all the stages, such as transportation, assembling in situ, disassembling and especially during its operation. Fig. 5 reveals a snap shot of the construction sequence where one floor is being assembled.

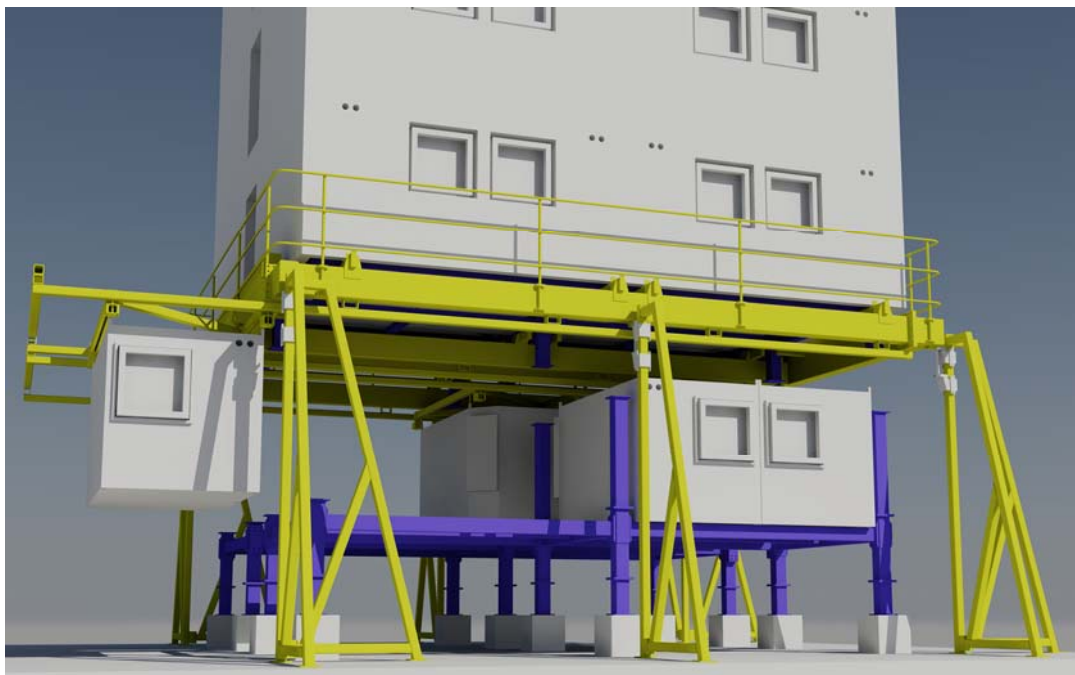

Figure 5. Snapshot of the assembly of one 3D module [4]

The stiffness of the grid is very important for the building since it provides the stability during erection. In order to keep the balance in the grid, the hydraulic jacks shall keep the grid accurately balanced. Nevertheless, the grid's stiffness, provided by the six long RHS 500x300x16 beams,

compensates small variations on an eventual lack of accuracy.

3.2.1 Sliding cantilevers

Sliding cantilevers are structural elements fixed to the grid which promote the building's erection by

applying vertical forces on the beams in the vicinity of the columns (see Fig. 6).

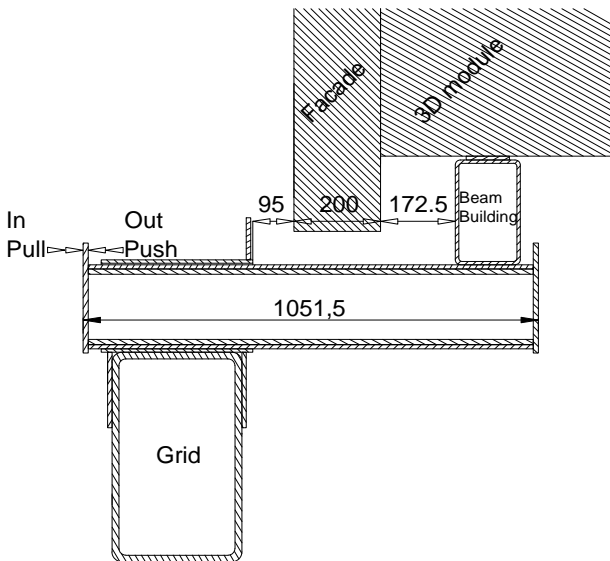

Figure 6. Detailed section of a sliding cantilever in lifting operation [4]

As shown in Fig. 6, they are mainly composed of two tubes, attached to the grid, where the internal tube moves freely inside the outer tube which is welded to grid. Two distinct positions are possible to admit; either in, beneath the building, to promote the building's erection or out, allowing the grid to move freely throughout the outer perimeter of the building.

The sliding cantilever length covers the distance from the grid to the building's beams, which implies the 3D modules (172.5 mm), claddings (200 mm) and the necessary tolerances (95 mm) for the grid to operate according to Fig. 5.

3.2.2 Conveyor system

The conveyor system results from a research performed to streamline the assembly of all the elements in the building, by moving/sliding the elements directly from the lorry to its final position (see Fig. 7). The conveyor system is fixed to the grid and unloads the elements from the lorry by lifting and sliding them to their final position according to the sequence of assembly, reducing the manoeuvring time. Thus, transportation of the elements to the construction site follows the construction sequence while the conveyor system unloads and assembles.

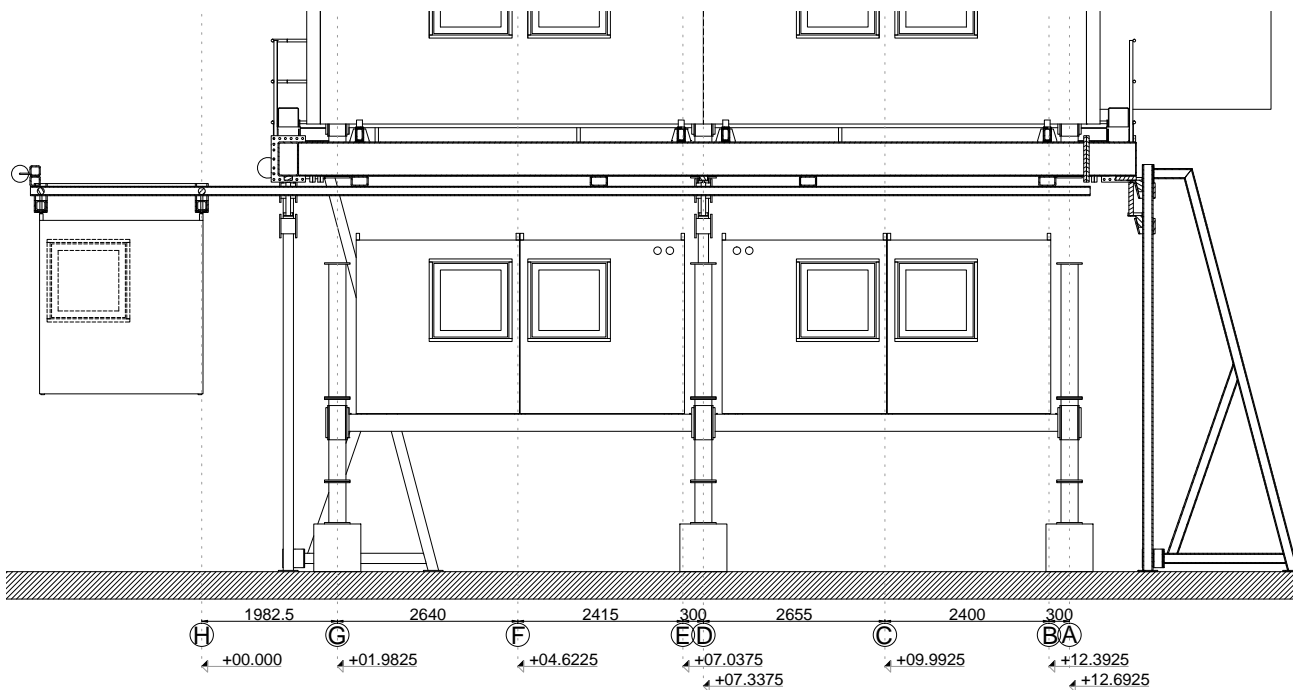

Figure 7. Different horizontal positions according to sequence of construction [4]

3.2.3 Lifting mechanism

The lifting mechanism promotes the building erection while it ensures the balance of the whole structure in a sequence of vertical moves coherent to the construction sequence. As for the conveyor system and its horizontal positions, the series of vertical movements performed by the lifting mechanism are predefined, as shown in Fig. 8. The different vertical positions represent important stages of the construction sequence and are related to the geometry of the building and characteristics of the lifting mechanism itself. For instance, position A is where the building's erection is initiated, whereas position B represents the level where the building, in a descending movement, meets the pre-assembled floor below for consequent tightening of column-splices connections.

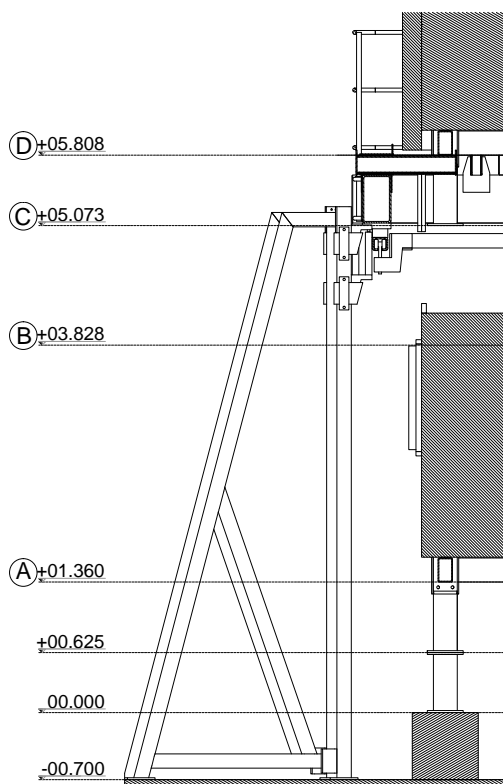

Figure 8. Different vertical positions according to the sequence of construction [4]

The development of the Frameup system benefits from a stepwise detailed 3D modeling and structural analysis and design tools [4]. However, when it comes to attest the reliability and efficiency of the system, a full scale feasibility test

is essential and is performed on the majority of the sequences of construction (see Fig. 9).



Figure 9. Full scale feasibility test [4]

4 Conclusions

Within the whole sequence of construction, the conveyor system and lifting mechanism have their entire operation, such as the horizontal and vertical positions, defined and synchronized with tasks such as transportation, assembly, etc. The systematization and industrialization of the whole execution process, creates adequate conditions for a more accurate control over the construction scheduling.

Thus, the present paper introduces an innovative construction method for modular buildings, where the Lifting system and its different components represent a major achievement towards the time and costs savings. Therefore, based on the developed construction method and its implementation in a full scale feasibility test, the following conclusions are drawn:

- The full scale feasibility test has demonstrated the validity of the Frameup system since the majority of the sequences of construction were tested successfully.

- The Lifting system is able to reduce the execution time because it takes the advantage of prefabricated, modular elements and the 3D modules are directly assembled in their final position by the originally designed conveyor system.

- The risks and time losses associated with work at height and erection of construction material do not exist, since the majority of the assembly work

is performed at the ground level. Quantity of the work to be performed in-situ is heavily reduced which additionally improves safety and execution speed at the construction site.

-The specific construction method introduced by the Frameup system has the advantage of performing the whole work under protection of the roof and building. This may allow for the extension of the construction period with less cost, especially in places where climate is an issue. Moreover, it allows for removing of the lower floors without interfere on the roof structure.

The combination of these factors proves the feasibility of the Frameup system. However, further research needs to be undertaken in order to optimize the lifting process, where a new feasibility test is intended to be performed before the construction of a Student Residence.

The solution presented has its focus on students, as it represents a large migrant community (with medium-term housing occupancy) and which exhibits a significant fluctuation on its population along time and location. Therefore, this system brings to light an innovative solution that intends to cope with the need to ensure housing in different locations and different periods of time, on the basis of assembly and disassembly of modular rooms and its transportation. Similar situations can be found throughout the world, where housing it is required either for medium or short-term periods, as for instances on sporadic mining explorations; on big events, such as sportive events, or on accommodations for refugees and evacuees.

5 Acknowledgments

The research leading to these results has received funding from the European Community's Research Fund for Coal and Steel (RFCS) under grant agreement n° RFSR-CT-2011-00035.

6 References

- [1] Veljkovic, M. et al, "FRAMEUP – Optimization of frames for effective assembling", Research Fund for Coal and Steel, all Technical reports, Grant Agreement Number: RFSR-CT-2011-

00035, European Commission, Brussels, 2013

- [2] Eurostat news release 49/2014, Labour costs in the EU28, European Commission, Brussels, 27 March 2014
- [3] Andersson, J., et al, "Bostadsrapport 2013", Sveriges förenade studentkårer (SFS), Stockholm, Sweden, 2013
- [4] Pimenta de Andrade, PA 2014, "Innovative Construction of Student Residences: Frameup Project". Licentiate thesis, Luleå University of Technology, Luleå, Sweden, 2014