

## Risk based framework for assessing resilience in a complex multi-actor supply chain domain

Ravulakollu, Anil; Urciuoli, Luca; Rukanova, Boriana; Tan, Yao-hua; Hakvoort, Rudi

**DOI**

[10.1080/16258312.2018.1540913](https://doi.org/10.1080/16258312.2018.1540913)

**Publication date**

2018

**Document Version**

Final published version

**Published in**

Supply Chain Forum

**Citation (APA)**

Ravulakollu, A., Urciuoli, L., Rukanova, B., Tan, Y., & Hakvoort, R. (2018). Risk based framework for assessing resilience in a complex multi-actor supply chain domain. *Supply Chain Forum*, 1-16. <https://doi.org/10.1080/16258312.2018.1540913>

**Important note**

To cite this publication, please use the final published version (if applicable). Please check the document version above.

**Copyright**

Other than for strictly personal use, it is not permitted to download, forward or distribute the text or part of it, without the consent of the author(s) and/or copyright holder(s), unless the work is under an open content license such as Creative Commons.

**Takedown policy**

Please contact us and provide details if you believe this document breaches copyrights. We will remove access to the work immediately and investigate your claim.



## Risk based framework for assessing resilience in a complex multi-actor supply chain domain

Anil Kumar Ravulakollu, Luca Urciuoli, Boriana Rukanova, Yao-Hua Tan & Rudi A. Hakvoort

To cite this article: Anil Kumar Ravulakollu, Luca Urciuoli, Boriana Rukanova, Yao-Hua Tan & Rudi A. Hakvoort (2018): Risk based framework for assessing resilience in a complex multi-actor supply chain domain, Supply Chain Forum: An International Journal, DOI: [10.1080/16258312.2018.1540913](https://doi.org/10.1080/16258312.2018.1540913)

To link to this article: <https://doi.org/10.1080/16258312.2018.1540913>



© 2018 The Author(s). Published by Informa UK Limited, trading as Taylor & Francis Group.



Published online: 09 Nov 2018.



Submit your article to this journal [↗](#)



Article views: 30



View Crossmark data [↗](#)

## Risk based framework for assessing resilience in a complex multi-actor supply chain domain

Anil Kumar Ravulakollu<sup>a</sup>, Luca Urciuoli<sup>b,c</sup>, Boriana Rukanova<sup>d</sup>, Yao-Hua Tan<sup>d</sup> and Rudi A. Hakvoort<sup>e</sup>

<sup>a</sup>Faulty of Technology Policy and Management, Delft University of Technology, Delft, the Netherlands; <sup>b</sup>Department of Industrial Economics and Management, KTH Royal Institute of Technology, Stockholm, Sweden; <sup>c</sup>MIT International Logistics Program, Zaragoza Logistics Center, Zaragoza, Spain; <sup>d</sup>Section Information and Communication Technology, Faculty of Technology, Policy and Management, Technical University Delft, Delft, the Netherlands; <sup>e</sup>Section Engineering Systems and Services, Faculty of Technology, Policy and Management, Technical University Delft, Delft, the Netherlands

### ABSTRACT

Risk management frameworks offer excellent tools to identify and manage risks in supply chains. Existing tools can be used to evaluate impacts of countermeasures, however, analysts struggle with modelling how disruptions escalate in complex supply chain systems within a certain amount of time and across several stakeholders. On the contrary, the resilience discipline offers the possibility to understand how a supply chain reacts to disruptions as a function of time. Hence, this paper integrates the concepts of resilience with risk management techniques and develops a risk based resilience assessment framework in a multi-actor context. Further, the framework is operationalized by developing a computer based tool that is tested in case of fruit import in Netherlands.

### KEYWORDS

Risk analysis; supply chain resilience; multi-actor analysis; resilience triangle; risk matrix; cost impact analysis

## Introduction

With risk events often affecting the operations severely and leading to delays in materials and cash flows, discipline of supply chain risk management (SCRM) has evolved significantly over recent decades (Chopra and Sodhi 2004). Approaches to manage risks usually align with principles of international standard 31000:2009. They focus on identifying risks, analysing, evaluating, treating, monitoring and reviewing, and reporting (ISO/IEC 2010).

The application of these frameworks, however, is not straightforward. Researchers point out the interconnectedness of risks, countermeasures and domino effects as main challenges (Wagner and Bode 2008; Chopra and Sodhi 2004, 2014). It gets complex particularly when considering the dynamics of multidimensional, contextual, and subjective actor-dependent aspects of risks (Manuj and Mentzer 2008; Urciuoli et al. 2014; Norrman and Jansson 2004). Consequently, it is necessary to systematically analyse risks along contextual time and space dimensions.

In resilience discipline, time dimension has been central to understand and measure resilience (Rose 2007; Sheffi and Rice Jr 2005; Walker et al. 2004). Its importance in preventing/resisting events (ISO 2011), and in case of disruptions, in bouncing back to resume normal business activities, depending on capabilities in the system has

been well recognised (Christopher and Peck 2004). However, resilience frameworks lack systematic approaches to support the identification of countermeasure capabilities, assessing them based on interconnectedness and evaluating their feasibility against potential impacts (Wieland and Marcus Wallenburg 2013). Interestingly, RM frameworks accommodate systematic approaches to identify and evaluate countermeasure strategies (Mullai 2006; Bichou 2008). However, both disciplines fail to address contextual dynamics of interconnectedness in multi-actor systems (Urciuoli and Hintsä 2016; Norrman and Jansson 2004; Smith and Fischbacher 2009).

It is evident that linking resilience to systemic RM framework would provide interesting insights on identifying risks, studying their interconnectedness with countermeasures and importantly paving way to understanding further the assessment and quantification of resilience. Though the need for such integration has been identified in research literature, not much has been done to explore their complementarity (Falasca, Zobel, and Cook 2008; Mitchell and Harris 2012; Jüttner and Maklan 2011; Bevilacqua, Ciarapica, and Marcucci 2017).

In an attempt to push the boundaries, research questions formulated are: how to position and quantify resilience in an integrated risk management framework? In light of this integration, how can

resilience be quantified in a multi-actor context of supply chain?

Risk Based Resilience Assessment (RBRA) framework and its Excel based tool were developed to answer the research questions. They are aimed at assessing risks, evaluating their impacts and quantifying resilience in intricate systems of multi-actor supply chains. The research process was structured using Design Science Research (DSR) framework and aligned with its guidelines, RBRA tool was assessed by demonstrating it using a case of avocado trade lane between Kenya and the Netherlands.

The following section reviews the existing literature on notion of resilience and its measurement, impacts of countermeasures and effects of multi-actor dynamics. The methodology section introduces the DSR framework. Next section lays down foundations that led to the development of RBRA. Thereafter, RBRA framework is presented and the RBRA tool is demonstrated. Finally the results and observations are discussed and conclusions are provided in the end while summarising the implications for researchers and practitioners.

## Literature review

### Risk management frameworks

The international standard ISO 31000 lays down iterative and stage wise guidelines for managing organisational risks. It identifies risks as effects of uncertainty on the organisational objectives. The guidelines could be used by any organisation regardless of the industry, operation and the complexity (Purdy 2010; Gjerdrum and Peter 2011). RM frameworks that organisations adopt to address operational risks are often built around standard Risk Assessment (RA) techniques (Mullai 2006; Bichou 2008). These can be qualitative (like check lists, HAZOP), quantitative (like Bayesian network analysis, Quantitative Risk Assessment) and hybrid (like Event Tree Analysis (ETA), Fault Tree Analysis (FTA)) (Marhavilas, Koulouriotis, and Gemeni 2011; Yang, Bonsall, and Wang 2010; Martins and Maturana 2010; Lee et al. 1985).

Further, RA techniques are used for specific purpose in RM processes (Mullai 2006). For instance, FTA is used to identify multiple causes leading to risk event through paths constructed by inductive reasoning following Boolean operations (Lee et al. 1985; Martins and Maturana 2010). ETA, on the other hand, is used to identify possible consequences of a risk event by constructing decision tress (Tummala and Schoenherr 2011; Norrman and Jansson 2004).

Bow-tie techniques captures both threats (causes) and impacts (consequences) around risk events. By placing both preventive and reactive countermeasures (safety barriers) at respective positions, bow-tie

techniques presents a complete picture of flow of events (Mokhtari et al. 2011). In fact, bow-tie framework can be considered to be a combination of FTA and ETA as shown in Figure 1 (de Ruijter and Guldenmund 2016).

### Notion of resilience

Researchers attempted to define resilience by aligning it with the notions adopted from different disciplines like ecology, sociology, economy or psychology (Bevilacqua, Ciarapica, and Marcucci 2017; Rose 2007; D'Lima and Medda 2015). As a concept in supply chain domain, it refers to the capability of firms to respond timely to disruptive events and ensure continuity of their business processes and operations (Sheffi and Rice Jr 2005; Chopra and Sodhi 2004).

Just like disasters, minor business disruptions could also lead 'devastating ripple effects' in supply chain (Norrman and Jansson 2004). Pettit, Croxton, and Fiksel (2013) establish that operational risks often bear severe economic impacts among parties along supply chains. They consider vulnerabilities to such risk events and the capabilities of the firms to resist the impacts as being two constructs of resilience. Similarly, Välikangas (2010) described resilience as being a combination of proactive and reactive capacities. Proactive strategies focus on risks forecasting and prevention whereas reactive strategies are organisational actions in response to environmental changes (Lengnick-Hall and Beck 2005). Rose (2007) diversified *static resilience*, as inherent capabilities to withstand impacts and *dynamic resilience* as reactive capability to recover timely. Wieland and Marcus Wallenburg (2013) by referring proactive component of resilience as 'robustness' and reactive component as 'agility' differentiate two dimensions of resilience. Ivanov and Sokolov (2013), similarly, study resilience as combination of robustness, flexibility and adaptation. However, flexibility as such is an attribute that can facilitate effective adaptation of the firms to perturbations while maintaining output performances (Stevenson and Spring 2007). Broadly, Bruneau et al. (2003) stipulated three aspects of resilience as being reduced probability of failures, reduced consequences of failures, and reduced time to recovery. While the first two ascribe to robustness dimension, the third one ascribes to agility dimension.

### Measuring resilience

Embracing the challenges, recent researchers have proposed few approaches, qualitative and quantitative, to measure resilience. On the quantitative front, Soni, Jain, and Kumar (2014) propose the exploitation of graph theory to develop a Supply Chain Resilience Index (SCRI) aiming to explain the interdependencies

of several enablers of resilience through a unique index. Ambulkar, Blackhurst, and Grawe (2015) develop and empirically test a scale to measure resilience. (Klibi and Martel 2012) develop several stochastic programming models incorporating resilience seeking formulations in network design models, i.e. 'predispositions of network resources favouring risk avoidance and mitigation'. Spiegler, Naim, and Wikner (2012) refers to inventory levels and shipment rates, and by applying system dynamics define the resilience as the integral of the Time Absolute Error (ITAE). Barroso et al. (2015) compute and define a company resilience index as the area of the triangle pattern showing the performance loss. Thereafter the supply chain risk resilience index is computed as an average of the resilience of the companies in the supply chain. At individual company level, Rose (2007) deduces direct economic static resilience (DSER) as being the percentage of overall possible economic damage that could be avoided by the firm due to its inherent resilient characteristic. Following a qualitative approach, Pettit, Croxton, and Fiksel (2013) develop a Supply Chain Resilience Assessment and Management tool to measure resilience as a combination of factors and sub-factors (or also capabilities) related to flexibility, capacity, efficiency, visibility, collaboration etc. The tool could be used to evaluate the current state of resilience of the firms and aid them in making strategic decisions.

### *Countermeasures and their operational impacts*

Companies adopt various countermeasures to mitigate risks and improve resilience. Yet, the impact of these strategies might not be known in advance, especially because it is difficult to figure out, a priori, how risks escalate and/or are interconnected. Chopra and Sodhi (2004) remind that manager can increase inventory levels to withstand disruptions due to delayed shipments. However, this could lead to risk of generating excesses or wastes subjective to market demand. Strategies need to create flexible 'responses to market uncertainties' (Kamrad and Lele 1998). Likewise, some of the organisational strategies or capabilities to boost performance, could become 'rigidities', hindering a quick resolution or maybe even worsening performance (Lewis 2003).

Countermeasures at disposal of managers, for preventive and recovery purposes are multiple, and consist of managerial strategies, operational routines and innovative technologies. Jüttner, Peck, and Christopher (2003) explain that to mitigate economic losses in supply chains, strategies of avoidance, control, cooperation and flexibility are adopted. Risks could be terminated by simply not dealing with vulnerable suppliers (Manuj and Mentzer 2008; Miller 1992). Strategies like insurances, contracting, outsourcing and collaboration could

transfer and distribute risks among parties in the chain. Incentives, portfolio of suppliers and investments in technologies could treat the risks. Redundancy, such as having inventory buffers, is seen as increase in flexibility (Sheffi and Rice 2005).

Strategies to integrate sensor technologies in digital eco-systems, increase visibility and supply chain managers gain better control of operation and coordination. By monitoring early warning signals, risk prevention can be improved or recovery measured could be positioned speeding up the recovery (Preble 1997). Some of the concepts that are being tested on a large scale are data pipelines, single windows, and blockchain technologies (Klievink et al. 2012; Henningsson et al. 2016).

### *Domino effects and multi-actor dynamics*

The process of quantification of resilience is intrinsically intertwined with the known domino effects of risks and subjective risk perceptions (Chopra and Sodhi 2004; Wagner and Bode 2008; Norrman and Jansson 2004). Failure of one single actor could lead to failure of the whole supply chain depending on the business relationships. These relationships could be rigid based on the management strategies adopted along just-in-time and lean principles. Sometimes harmless and overlooked disruptions, at one end of the supply chain, may exacerbate into significant threats for focal companies or downstream distributors (Christopher and Peck 2004; Jüttner, Peck, and Christopher 2003). Hence, being resilient in a supply chain means re-establishing operations not only in a single company, but at every single stakeholder in the supply chain.

However, these actors may have different perceptions of risks. Likewise, due to the different operating contexts and processes, impacts of countermeasures could be different. Hence, the domino dynamics need to be analysed from a multi-actor perspective. By referring to theories of cognitive psychology and neuroscience Slovic et al. (2004) highlight that humans comprehend risks under two systems: *analytic* and *experiential*. While analytical system refers to the logical and data driven decisions, in experiential system the decisions made are usually intuitive, quick and not easily accessible to conscious awareness. The main findings of Slovic et al. (2004) include that people's perception of an event as a risk is influenced by their *feeling* towards the probable outcome. It is influenced largely by their dread towards possible outcomes or the fear of unknown outcomes. Decisions related to events and activities depend on the *values* that managers assign to them. It can be added that in a supply chain positive or negative feelings/emotions are connected to the different economic impacts that single firms may have in case of a disruptions. Due to the typical opportunistic

behaviour of supply chain firms, these perceptions may differ, calling for models aiming to understand domino-multi-actor based dynamics.

### Methodology

To carry out this research, Design Science Research (DSR) framework (Figure 2) proposed by Hevner et al. (2004) was used. The objective of the framework is to develop an *artefact relevant* to the *business needs* within a particular *environment* comprising of people, organisations and technologies. The artefact is to be well grounded in the existing *knowledge base*. It is evaluated using established research strategies listed in Figure 2 and thereafter assessed and refined.

The framework is widely employed to develop and evaluate theories and artefacts in case studies. It is cited around 2097 times in case-study approaches in

various domains. Of these publications belong 313 belonged to the supply chain domain. To name a few, Martínez-Sala, Egea-López, García-Sánchez, & García-Haro (2009) evaluated the functionality of the designed artefact by collaborating with a Spanish company. The artefact was intended for ecological packaging and transportation of grocery goods for the entire product cycle. (Wolfert et al. 2010), realising the need for integrated information systems in agri-food supply networks, used the design-oriented case study of Dutch arable farming to develop a generic integration framework. Their case study results were abstracted to similar contexts by basing on the logic of theoretical replication (Eisenhardt 1989; Yin 1994). Further, to study the impacts on supply chain due to information flow impediments during extreme disasters, Day, Junglas, and Silva (2009) relied on the aftermath data of Hurricane Katrina to identify lapses in

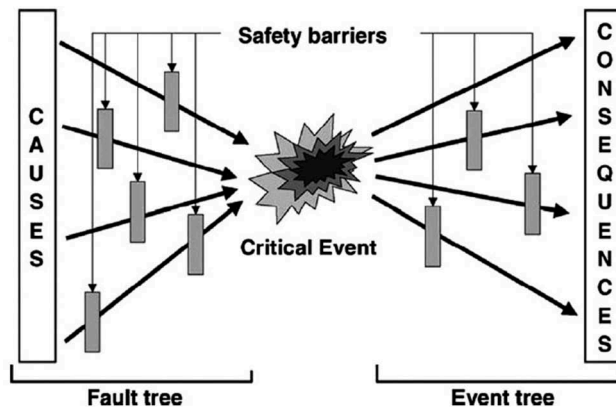

Figure 1. Bow-tie framework (de Ruijter and Guldenmund 2016).

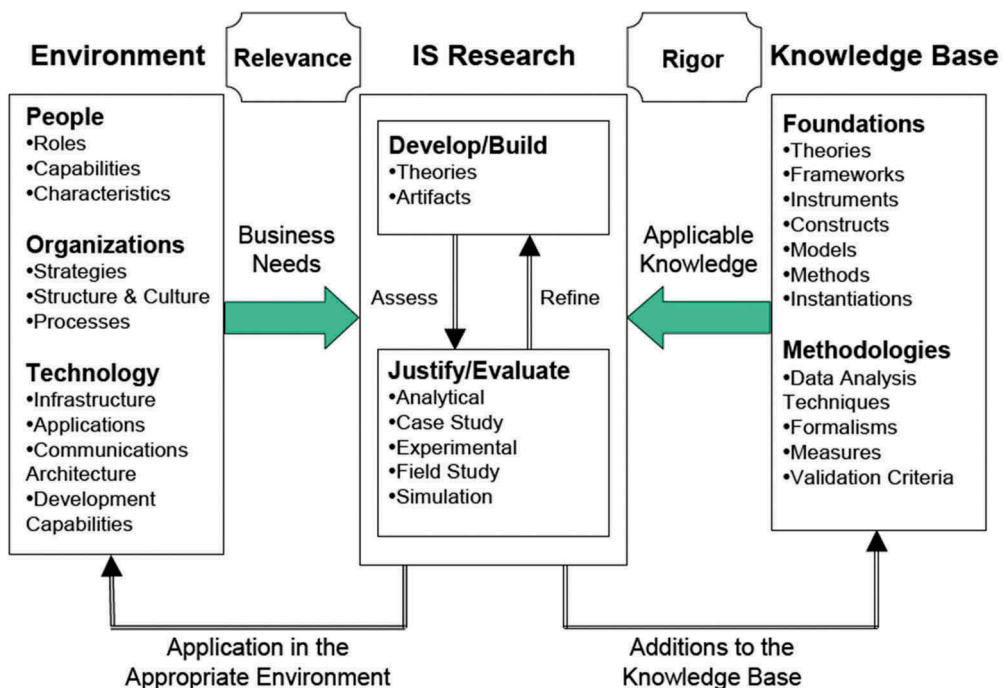

Figure 2. Design science framework proposed by Hevner et al. (2004).

information handling, affecting the relief and recovery operations of the organisations.

The process flow of the research according to DSR framework in Figure 2 is as follows. As mentioned the *environment* being studied is the supply chain domain, which is inherently a complex system with intricate socio-technological interactions among multiple parties. The *relevance* of the research is derived from the *business needs* for having a comprehensive framework for assessing risks and quantifying resilience to improve overall quality of supply chain. These needs were gathered through semi-structured interviews and focus group discussions which involved academicians (which included researchers) and practitioners (which included traders, employees of shipping company and government authorities)

Standard research techniques were employed while extracting *applicable knowledge* from the *existing knowledge* to maintain the *rigour* of research. Literature review was conducted to identify and analyse the SCRM frameworks that are largely adopted by practitioners. The frameworks studied were AEO Compact model, used for customs and security risks (EU Commission 2006; Liu, Tan, and Hulstijn 2009), Formal Safety Assessment framework for transportation risks (Rosqvist and Tuominen 2004), Safety Case for health and safety risks (Kelly 2004; Bishop and Bloomfield 2000), Quantitative Risk Assessment (QRA) for safety risks (Mullai 2006; Apostolakis 2004) and Marine Accident Risk Calculation System for marine accidents (Fowler and Sørsgård 2000).

By aligning the business needs and theoretical findings the *artefacts* developed were Risk Based Resilience Assessment (RBRA) framework and an Excel based tool. By considering the case of avocado trade between importing Company A in the Netherlands and exporting Company B in Kenya,

artefacts were *assessed* and *refined*. Company A, was located in Rotterdam, close to the place of research making it convenient for data gathering. Importantly, the trade lane had typical characteristics of a supply chain with an interplays of multiple actors and middlemen. There was no clear visibility on the upstream operations and transactions. Moreover, with the parties involved being small scale the supply chain was vulnerable to minor disruptions which often led to domino-like impacts, making the ideal for demonstrating the RBRA tool.

## RBRA framework

After studying the five RA frameworks mentioned earlier, it was found that they all align partially with ISO guidelines. However, they fall short in incorporating the multi-actor dynamics and recognising the impacts due to interconnectedness of countermeasures. Further, they were not flexible to accommodate the concepts of resilience quantification.

RBRA framework developed consists of five phases based on guidelines of ISO 31000. The limitations of the studied RA frameworks were addressed by incorporating actor analysis principles at each stage and by integrating the concepts of resilience, it is made comprehensive. The framework is presented in Figure 3 and each of the phases are discussed below.

### System establishing phase

The boundaries of system that is to be analysed are established in this phase. Often, the chain begins with supplier as the source and the buyer as the end. The three functional layers that operate in a supply chain are logistics, transaction and governance layers (Hesketh 2010; van Oosterhout 2008; Willis and Ortiz 2004). Multiple parties appear at each level and the

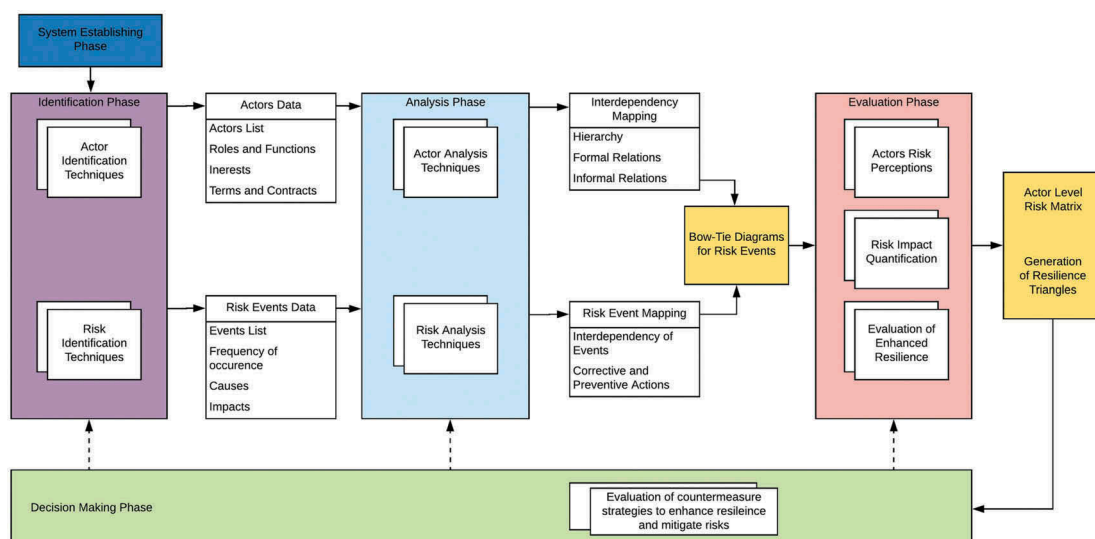

Figure 3. Risk Based Resilience Assessment (RBRA) Framework.

level of detail depends on the scope and objectives of analysis.

### Identification phase

This is primarily information gathering phase. All the available data about the risks and the actors involved are identified. Traditional risk identification techniques found in literature (Mullai 2006; Marhavilas, Koulouriotis, and Gemeni 2011; Bichou 2008) are used to create inventories of risk data which includes events, their occurrences, causes and frequency of their occurrences, possible consequences and existing mitigation measures. These techniques often include analysing historical data, contractual agreements, and carrying out expert interviews help in identifying this data. Similarly, using actor identification techniques, like the ones listed by Hermans and Thissen (2009), actor roles, responsibilities, the formal and informal relations are identified in this phase.

### Analysis phase

The objective of this phase is to construct risk centric bow-tie diagrams for each risk event while capturing the multi-actor dynamics of system. Figure 4 illustrates this ideology. A risk event could be triggered either by the internal causes (Cn), which are the actions of actors operating in the system, or by the external factors that are beyond the boundaries of the system. Occurrence of these events could lead to impacts (Qn) which affect multiple parties in the chain. Performance indicators (KPIs) chosen based on organisational requirements often determine the impacts. The severity of these impact however varies among parties depending upon their respective economic strengths, KPIs that are used to measure the impacts, and the deployed preventive and corrective countermeasures (shown in blue and yellow dots in Figure 4).

### Evaluation phase

In this phase, robustness of actors towards various risks and the agility with which they recover from them are assessed. An actor-centric risk matrix (Figure 5) is generated to categorise risks for each actor based on their organisational interests. By positioning risks along the axes of level of impacts and likelihood of occurrences (LC), the resilience dimension of robustness for each actor towards those risks could be visualised. To evaluate LC of risk events techniques like FTA and Bayesian network analysis could be effective. In development of RBRA tool, Boolean logic of FTA has been used. Its application in the tool is discussed further in the following section.

Actors are robust towards those risks which fall in lower left quadrant of the matrix, whereas they are vulnerable to the ones which are in the top right quadrant. Further, by using the concept of resilience triangle (Sheffi and Rice Jr 2005; Rose 2007; Bruneau et al. 2003), insights on agility of actors could be gathered by assessing the effectiveness of existing countermeasures (both preventive and corrective) in recovering from the impacts along time dimension.

Earlier, it was noted that Rose (2007) proposes to firstly estimate the overall possible economic damage a disruption can bring about. By taking its as the base case, actual damage that occurred is to be assessed. This difference is used to determine the inherent DSER of the system. Nevertheless since resilience is dependent directly on the countermeasures that are in place, RBRA narrows down further and attempts to assess firm's resilience that could be enhanced beyond its inherent capabilities. Further, Rose, unlike Bruneau et al. (2003), identifies resilience as being only a post-event property of the system. Whereas, RBRA adopts a proactive approach and considers preventive actions as being important countermeasures that improve resilience particularly along robustness dimension. They do so by reducing the LC of a risk event and also the possible impacts. Agility, on the other hand, depends on the recovery rate of the

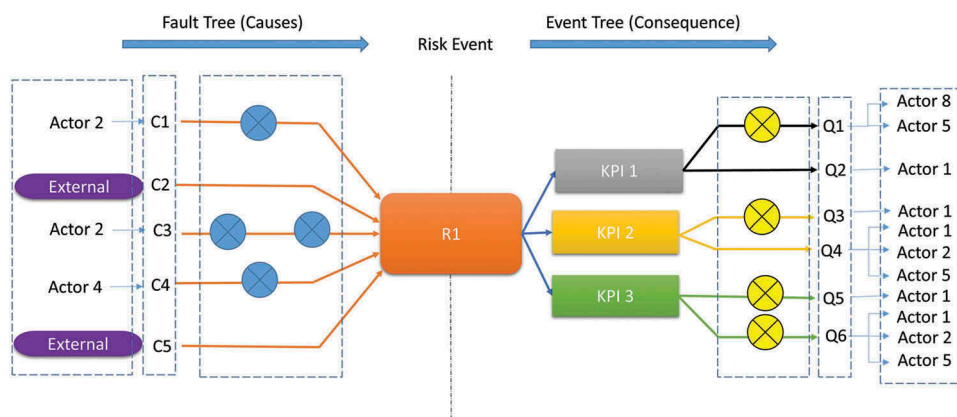

Figure 4. Bow-tie framework in multi-actor scenario.



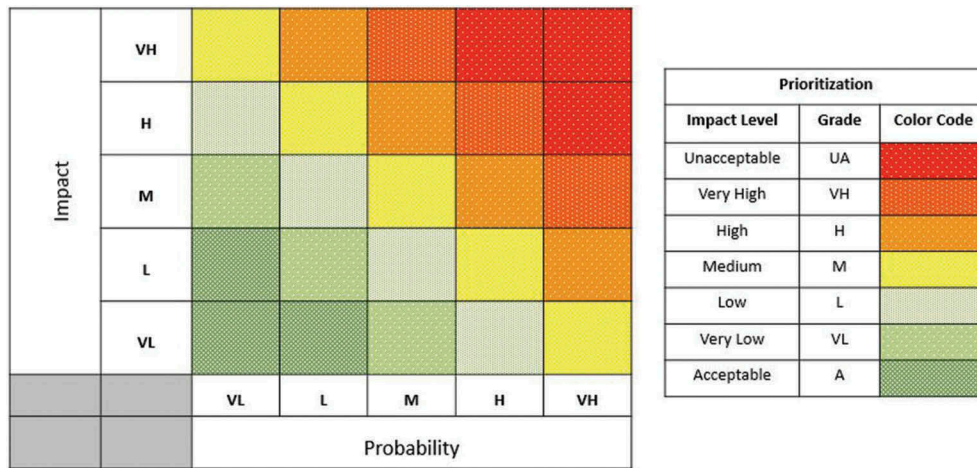

Figure 5. A typical 5 × 5 risk matrix.

system and can be improved through corrective countermeasures. Thus, enhanced resilience in terms of countermeasures per risk event per actor is measured as follows.

- Along robustness dimension through LC: If initial LC of a risk event is  $p_0$  and the new LC after a preventive countermeasure is  $p_1$ , then enhanced resilience when lowering the LC of risk event ( $RE_p$ ) is:

$$RE_p = (p_0 - p_1)/p_0 \quad (1)$$

- Along robustness dimension through impact level: If the initial impact of the risk event when no countermeasure is in place is  $I_0$  and impact level after a preventive action is in place is  $I_1$ , then the enhanced resilience when lowering the impact level ( $RE_I$ ) of a risk event is:

$$RE_I = (I_0 - I_1)/I_0 \quad (2)$$

- Along agility dimension through recovery time: If the initial time taken when no countermeasure is in place for the system to recover is  $t_1$  and the time that would take after a corrective action is introduced is  $t_2$ , then the enhanced resilience when lowering the recovery time ( $RE_t$ ) a risk event is:

$$RE_t = (t_1 - t_2)/t_1 \quad (3)$$

In terms of resilience triangle, enhanced resilience is the change in area of the triangle after implementing the counter measures (Bevilacqua, Ciarapica, and Marcucci 2017). In Figure 6 the area of the triangle ABC can be measured using the height of impact, BD and the length of the time, AC. The new resilience triangle after reduction in impact and recovery time is  $AB_2C_2$ . It can be noted

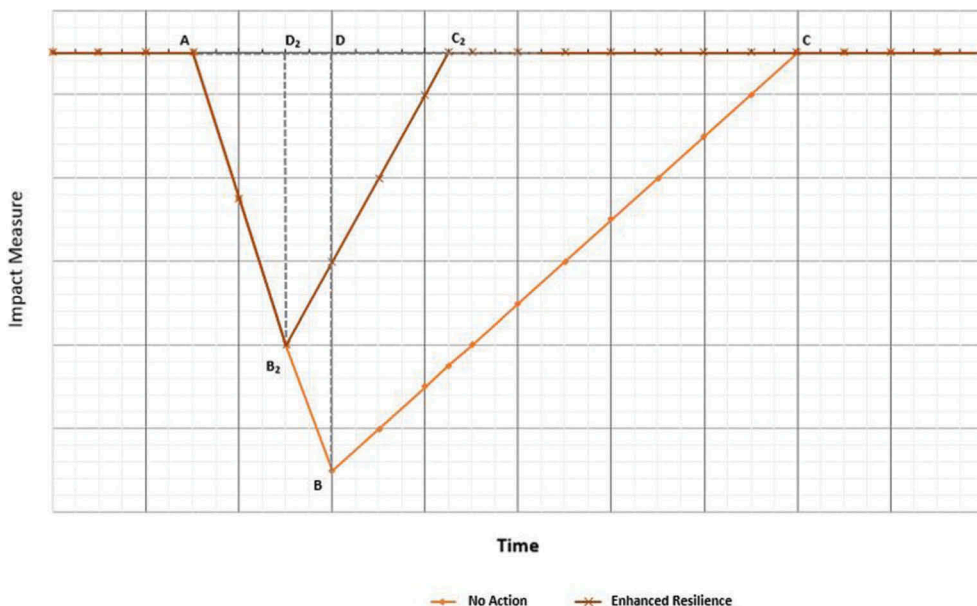

Figure 6. Enhanced resilience using Resilience Triangle.

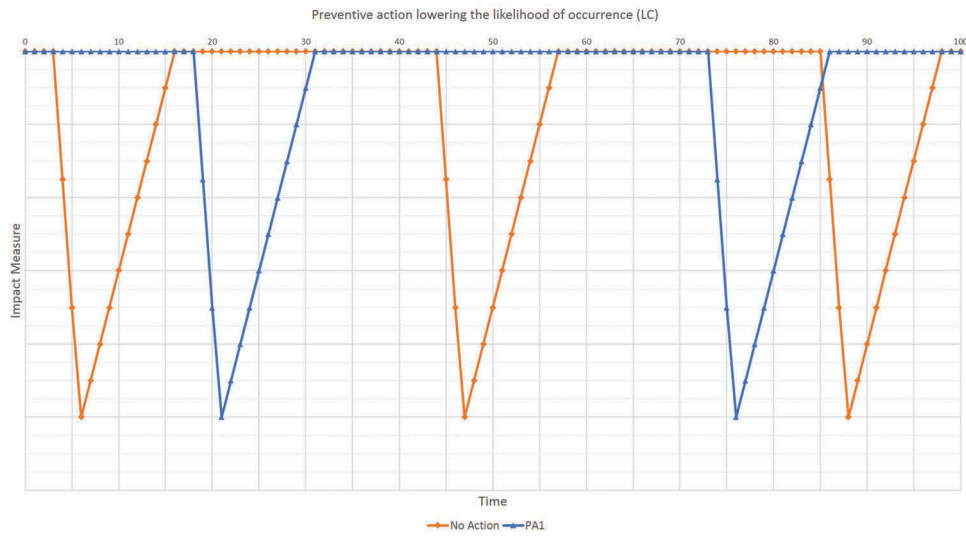

Figure 7. Preventive action to reduce LC of risk event.

that through preventive actions, the impact level was reduced and through corrective action the recovery rate was increased (i.e the overall recovery time was reduced).

The reduced area of the triangle is the area enclosed by  $BCC_2B_2$  which in other words is the enhanced resilience ( $RE_T$ ). Using equations (2) and (3) it can be deduced that:

$$RE_T = [1 - (1 - RE_t)(1 - RE_t)] \quad (4)$$

**Decision making phase**

During this phase the actors adopt strategies to mitigate risks and enhance their resilience by improving robustness and agility. In traditional risk management discipline risk aimed at moving the risks in matrix from higher to lower severity regions.

This is done by lowering LC of risk event or impact levels or both. These actions increase the robustness aspect of resilience. By incorporating the agility dimension which focuses on lowering the recovery time from the impact, the scope of risk management is broadened.

The objective of actors is to choose appropriate countermeasure strategies based on their capabilities and resources available to lower the area of their resilience triangles. If resilience per risk event is considered, by investing in reducing the height of triangle (impact level) or the base (recovery time) or by both, the area could be lowered. If resilience towards similar events over a time horizon with varying impacts (depending on contextual factors) is considered, then it is worth investing in lowering LC and increasing Mean Time Between Failures (MTBF) as shown in Figure 7. Figure 8 depicts the reduced area

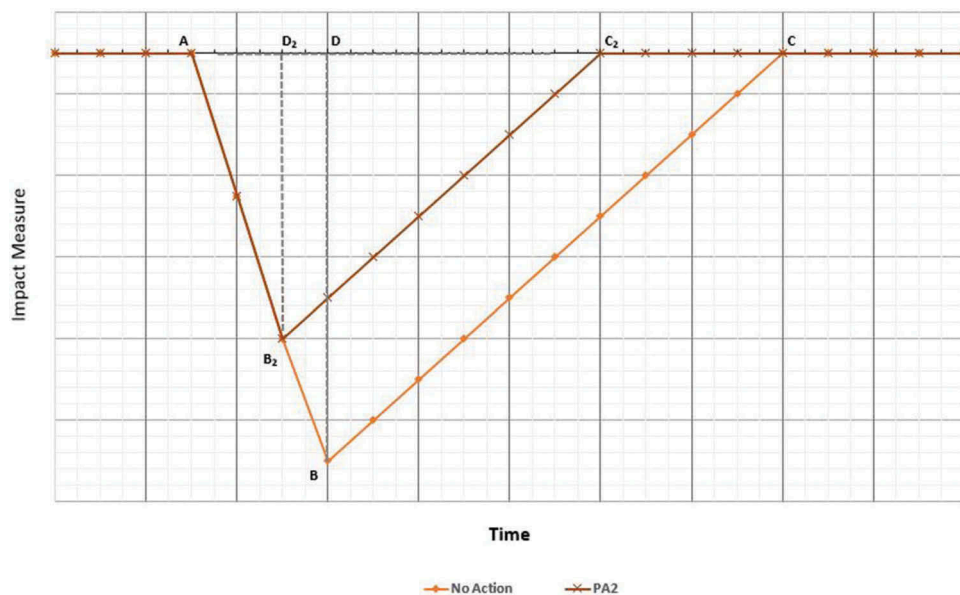

Figure 8. Preventive action to reduce the impact.

of triangle by having proactive measures in place to reduce the possible impacts.

For instance, by investing in security and intelligence features sea carrier could detect the piracy attacks well in advance and could react by averting the attack (i.e reduce LC of event) or equip themselves to counter attack (i.e lowering the impact).

Corrective actions on the other hand supplement the inherent recovery mechanisms and improve the agility of the system. As shown in Figure 9, they enhance resilience by reducing the area of the triangle from ABC to ABC<sub>1</sub>.

### Application of the RBRA tool

The framework was operationalised by developing a VBA based Excel application. It facilitates systematic gathering of risk data and the actors involved and thereafter, to generate risk-centric bow-tie diagrams and actor-centric risk matrices. The demonstration of the tool on an international trade lane of avocado shipments between Kenya and the Netherlands is discussed below.

### System establishing phase

The information about the trade was obtained by interviewing the associates of Company A, employee of Company C and analysing the documents like bill of lading and invoices. Company A located in Rotterdam, has a sales contract with Free Carrier (FCA) incoterms with Company B in Nairobi, Kenya. Company B procures fruits from multiple local suppliers, packages them and through forwarding Company D, ships them in a reefer container. The container is

transported from Nairobi to Mombasa, and then transported on sea carrier to Salalah where it is transhipped to either Antwerp or Rotterdam. Company C is responsible for sea transport while Company A is responsible for inland transportation at the import side. The regulatory bodies involved in export and import clearances are Org 1, Org 2, Org 3 and Org 4.

### Identification phase

*Risk Identification:* Data related to risk events were gathered both through interviews and by studying the company's documents. Overall, 12 major risk events were analysed. Of them risks R1 and R2 are related to temperature setting which is highly critical for the transportation of avocado, a perishable good. In this paper, these two risks are discussed in detail to demonstrate the logic behind the analysis.

### Risk R1: damage due to temperature changes in the container

To prevent avocados from ripening, an ambient temperature around 5°C is very critical. Any slight increase would expedite ripening process and could damage the whole cargo (of around €50,000) depending on how early in the chain did the deviation occurred. Company A cannot trace the exact location of deviation mainly because there is no continuous monitoring. However, the three independent causes that were identified for the deviation are: (C1) the drivers at the export side could disconnect the cooling system powered by diesel to save the fuel. (C2) the fruits might not have been pre-cooled before they were loaded into the container. (C3) Company C could be using faulty measuring device to read the temperature.

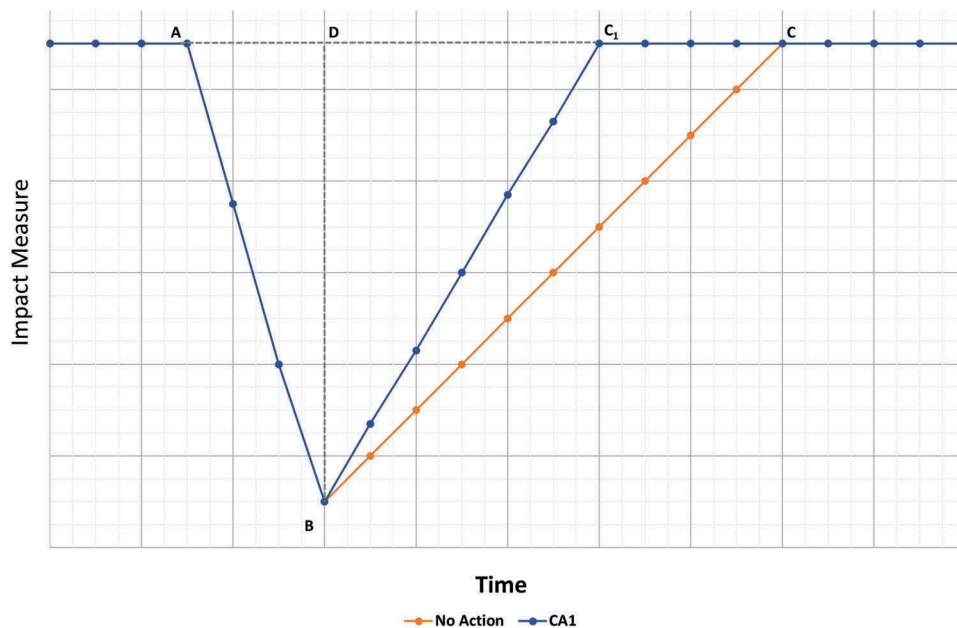

Figure 9. Resilience triangle with corrective actions.

**Risk R2: liability risk**

According to the contractual terms, depending upon where the cargo damage occurred, either Company B or Company C are liable to bear the costs for Company A. However it is not always straightforward to locate the exact point where the damage occurred in the shipping process. Company A deduces the location based on the severity of damage. This makes it uncertain as to when and on whom the liability terms would be invoked on B or C, in which case they could either bear the damage or contest the claim. Though such occurrence are rare, during the time of interview there was a dispute over this which was remained resolved since a year.

*Actor Identification:* In the systems establishing phase it was realised that at each stage of the trade process different actors appear. Table 1 lists the main actors along with their functionary roles.

**Table 1.** Actors along the trade lane.

Name <sup>a</sup>	Role
Company A	Buyer
Company B	Seller
Company C	Sea Carrier
Company D	Freight forwarder export
Company E	Producer
Company F	Trucking company import
Company H	Inter land Carrier Export
Company I	Inter land Carrier Import
Company K	Freight forwarder import
Company L	Inland Transport Export
Org 1	Government Agency
Org 2	Inspection Agency
Org 3	Port Authority
Org 4	Terminal Import
Org 5	Terminal Export
Org 6	Customs Export
Org 7	Customs Import

<sup>a</sup>Actual names of the firms have been anonymized for confidentiality.

**Analysis phase**

The main interdependencies operating in the trade lane are shown in Figure 10. Company A has direct contracts with Company B, Company C and Company K. Company A does not have visibility on the interdependencies at the export side. After studying the invoices it was observed that Company C and Company B are dependent on Company D for inland transportation. At the import side, Company K sub-contracts inland transportation to Company F.

In case of R1, basing on the interdependency map it could be deduced that Company B is responsible for cause C1 and Company C is responsible for causes C2 and C3. In case of R2, depending on the location of the damage, Company A in turn puts a claim on either Company B or Company C. By transferring risk, Company A adopts a countermeasure strategy in the form a corrective action (CA1). In other words, domino effect was triggered through a liability contract. The flow of the impacts are illustrated using bow-tie diagrams in Figures 11 and 12.

**Estimating likelihood of occurrence of risk event**

According to Boolean logic used in Fault Tree Analysis (FTA) a risk event could be triggered in five ways: OR gate, AND gate, Exclusive OR gate, Priority AND gate, and Inhibit gate (Martins and Maturana 2010; Lee et al. 1985). The OR and AND logics used in RBRA tool to deduce the LC of a risk event from the possible causes are discussed below.

If P (RE) is LC of a risk event, which is triggered by n number of causes with P (Cn) being the LC of nth cause, and if:

1. Any of the causes could independently trigger (mutually exclusive) the risk event, then P (RE)

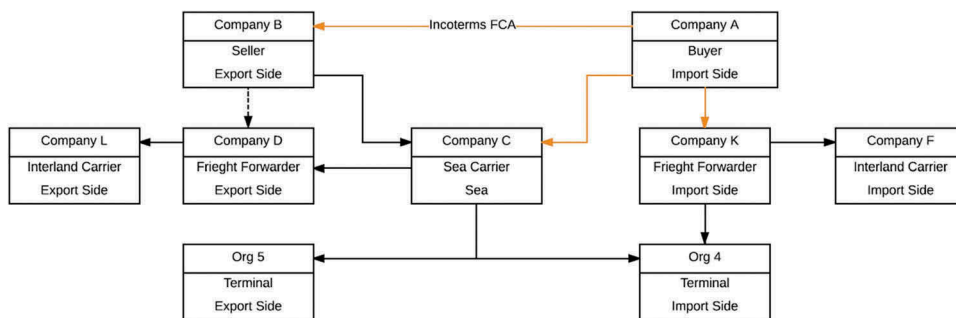

**Figure 10.** Interdependency map in the trade lane.

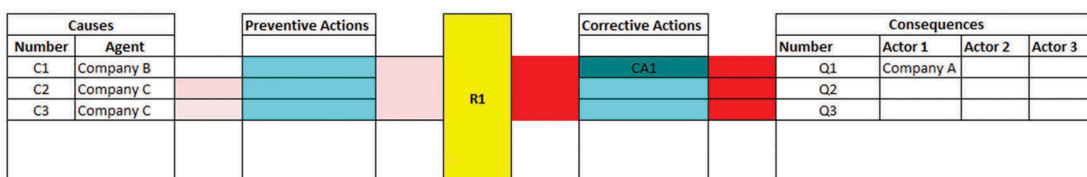

**Figure 11.** Bow-tie diagram for risk event R1.

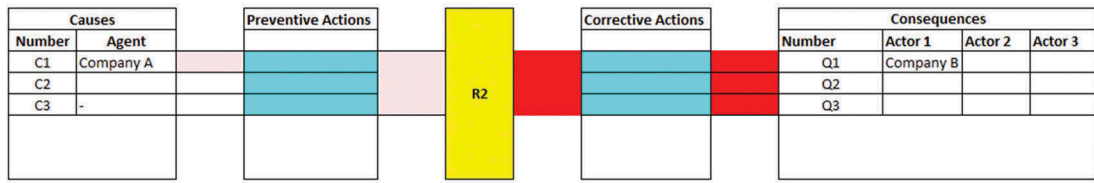

Figure 12. Bow-tie diagram for risk event R2.

would be equal to the maximum of LC values of all causes.

$$P(RE) = \text{Max} \{P(C1), P(C2), \dots, P(Cn)\}$$

2. The risk event could be triggered only when two or more causes occur together, then P (RE) would be the product of LC values of all these causes.

$$P(RE) = P(C1) * P(C2) \dots P(Cn)$$

Further, scaling in Table 2 is used to grade P (RE) values from very low (VL) to Very High (VH). For example, P (RE) = 0.50 implies that the risk event occurs 50% of the time and its grade is M. It should be noted that P (Cn) value however depends on historical data and experts inferences.

**Evaluation phase**

With the help of associates of Company A, the scale of impact for each impact range was established. Initially, a linear relation was assumed between the scale and the impact value. However, when the resulting the upper limit for the 'very low' impact region tuned out to of significantly high value (€ 10,000), Company A recalibrated the impact scale

Table 2. Grading of LC values, P (RE).

P(RE) Range		P(RE) Grade
Lower (>)	Upper (≤)	
0.8	1	VH
0.60	0.80	H
0.40	0.60	M
0.20	0.40	L
0.00	0.20	VL

LC of R1: From the past events it was noticed that P(C1) = 0.10, P (C2) = 0.15, and P(C3) = 0.10. Based on the OR gate logic, P (RE1) = 0.15 with grade VL.

LC of R2: According to Company A, invoking of liability contract is a rear event and through discussion it was established that P(C1) = P (RE2) = 0.10 with grade VL.

Table 3. Adjusted non-linear impact scale.

Impact Range		Grade	Scale
Lower (>)	Upper (≤)		
€ 30,000.00	-	VH	Very High
€ 10,000.00	€ 30,000.00	H	High
€ 2,500.00	€ 10,000.00	M	Medium
€ 750.00	€ 2,500.00	L	Low
€ 200.00	€ 750.00	VL	Very Low

meticulously. It resulted in a non-linear scale as shown in Table 3. Using this scale for all the 12 risks, RBRA tool generated a risk matrix for Company A (Figure 13).

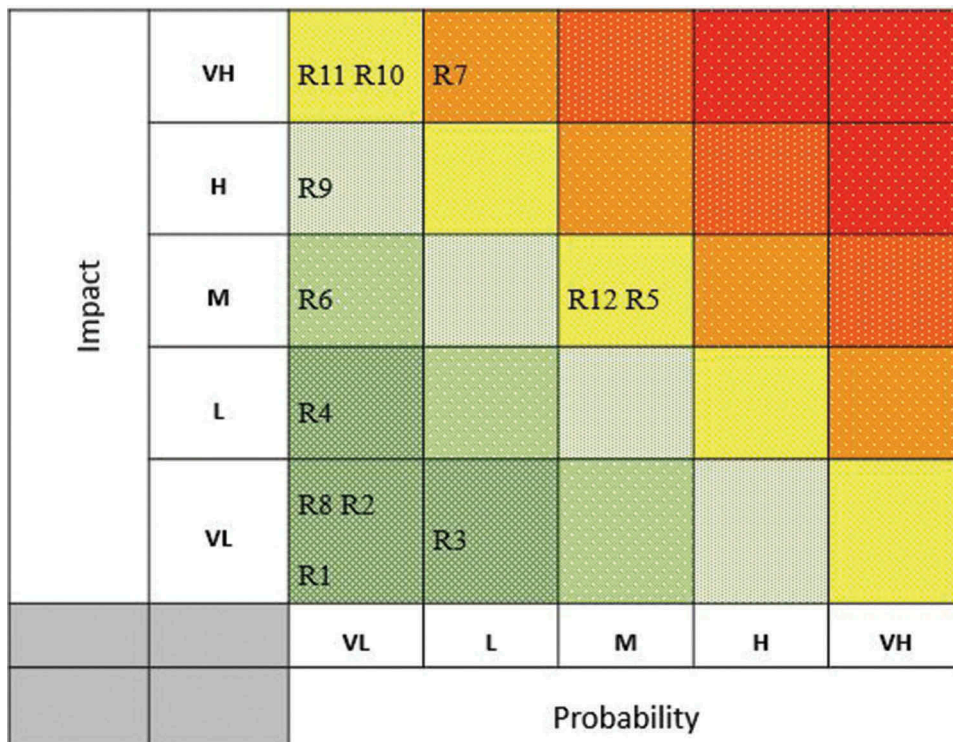

Figure 13. Risk matrix generated with non- linear impact scale.

Risk matrix shows that Company A has very few high priority risks. Further, by having claims in place it has significantly lowered the severity of risk R1. However, it does not mean that the company is completely resilient towards R1. It could be noted that recovery time through liability claim is a lengthy process. Therefore with regard to R1, Company A is robust but not agile.

### Decision making phase

For a full cargo damage loss for Company A, based on different countermeasure strategies, three kinds of scenarios can be constructed as shown in Figure 14. They are compared with the base scenario when no action is taken.

Scenario 1: Through the strategy of recovering damages through liability claims on Company B and Company C, Company A could recover the damages almost completely. However recovery time taken is long depending upon the negotiations.

Scenario 2: During the discussion with Company A, it was emphasised that they lacked the visibility on several supply chain processes at the export side and of them maintenance of temperature setting was one of them. By investing in a digital infrastructure like a sensor technology, Company A can continuously monitor the data fed into the system through the sensors in place in the container. Company A would then be in position to timely react to any temperature deviations or in the worst case, be in position to negotiate claims faster.

Scenario 3 – After discovering the damages, Company A could adopt an ad-hoc strategy to procure the fruits from the local suppliers. This could however cut down the profit margins for Company A and would not recover the damages completely.

For Company B on the other hand, there is currently no strategy in place to recover from claims. This leaves it exposed to the risks making the overall trade lane vulnerable. However, to make itself more resilient, Company B can adopt more stringent temperature monitoring methods (treat) or renegotiate the contractual terms with Company A to avoid the claims (transfer).

### Discussion

Reverting to research questions, first one was related to positioning the concept of resilience in RM framework and developing its quantification methodology. It was mentioned that threats posed by operational risks not only affect business processes but also impact the resilience of complex supply chain systems. RBRA framework in its identification phase emphasised the need to gather data related to actor interdependencies and to understand the spread of impacts among different parties operating in the chain. After carrying out traditional risk and actor analysis, in the evaluation phase the resilience of each actor per risk event is established. Based various countermeasures possible, in the decision making phase the actors using resilience triangle can strategize their actions. This positioning of resilience could be visualised in Figure 3.

Enhanced resilience, along the lines of robustness and agility, was estimated through the equations (1) to (4). Resilience triangle served as a visual mapping to understand the dynamics of resilience with preventive and corrective (or reactive) counter measure strategies. In scenario 2, a strategy of investing in sensor technology was identified to improve the resilience of Company A. As was noted by (Preble 1997), if technology were capable of relaying real time data of

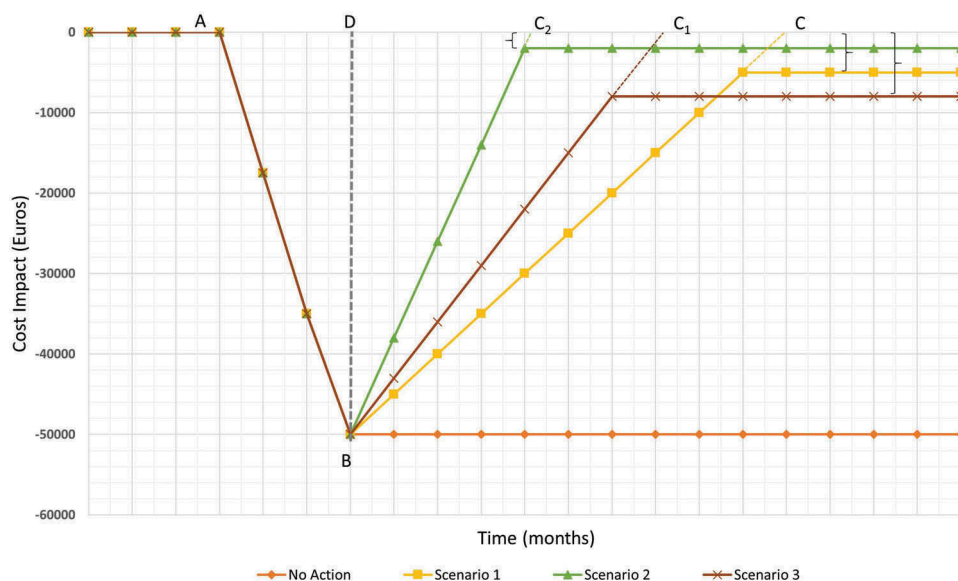
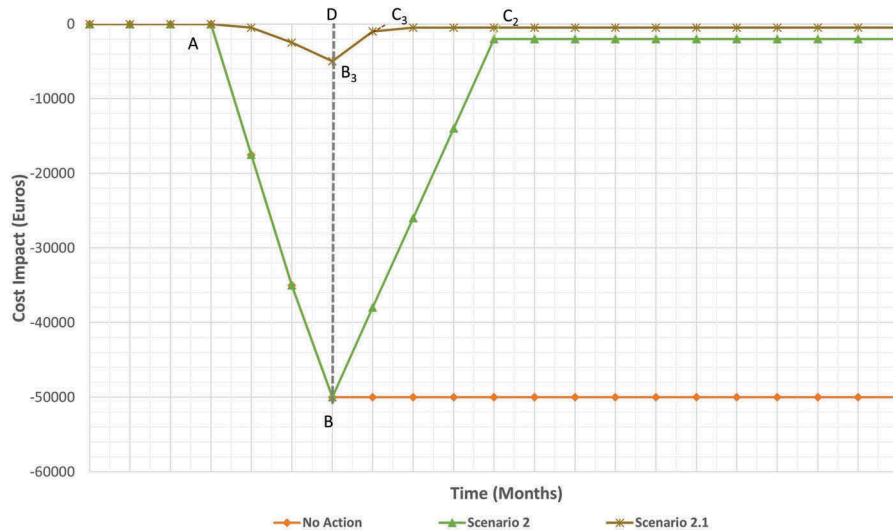

Figure 14. Strategies to improve resilience of Company A towards risk event R1.



**Figure 15.** Strategy of sensor technology with early detection of temperature deviation.

critical temperatures, Company A could react in a timely manner and mitigate the probable impacts. Resilience triangle in this case would look something like as shown in Figure 15 (Scenario 2.1). The impact would be reduced to large extent and the coping time could be further minimised. On a broader context, if technologies, like data pipeline as suggested by Klievink et al. (2012), are well integrated in ecosystems, visibility increases and supply chain managers gain better control of operation and coordination on global level (Henningsson et al. 2016).

Second research question called for the need to accommodate the contextual actor dynamics in quantification of resilience. Apart from establishing the existing actor relationships in analysis phase, emphasis was laid down in understanding the subjective perceived risks and their impacts. The necessity of establishing subjective severity levels of impacts of actors was observed when calibrating the impacts of Company A. Referring to Slovic et al. (2004), the adoption of initial linear scale was a result by analytical system of reasoning. The following adoption of non-linear scale however has no sound logical basis and was driven purely by assessing impacts through an experiential system based of feelings. Further by generating actor-centric risk matrix and resilience triangle, the resilience of individual actor is evaluated using RBRA framework.

## Conclusions and recommendations

The concept of supply chain resilience as a discipline in itself is still in its evolving stage. Studying it to address the complexities in supply chain particularly with interplay of several multi-actor interactions, needs a robust methodology for its quantification. One approach that was explored in this paper is exploiting the complementarities of SCRM

frameworks and resilience while integrating them and adapting to multi-actor supply chain systems. The interconnectedness among risks, actors and their countermeasures was explored and represented through the bow-tie framework. Risk matrix and resilience triangle gave insights on actor vulnerabilities and their sensitivities to various countermeasure strategies.

RBRA approach is a broad system level framework capable of accommodating analysis of various kinds of risks and disruptions. Simple Excel based tool demonstrated the possibility of operationalising it. By using higher programming and integrating with information technologies RBRA can be further developed to provide real-time solutions.

This research was partially funded by the CORE Project (nr. 603993), which is funded by the FP7 Framework Program of the European Commission. Ideas and opinions expressed by the authors do not necessarily represent those of all partners. disclosure statement

No potential conflict of interest was reported by the authors.

## References

- Ambulkar, S., J. Blackhurst, and S. Grawe. 2015. "Firm's Resilience to Supply Chain Disruptions: Scale Development and Empirical Examination." *Journal of Operations Management* 33: 111–122. Elsevier. doi:10.1016/j.jom.2014.11.002.
- Apostolakis, G. E. 2004. "How Useful Is Quantitative Risk Assessment?" *Risk Analysis* 24 (3): 515–520. Wiley Online Library. doi:10.1111/j.0272-4332.2004.00455.x.
- Barroso, A. P., V. H. Machado, H. Carvalho, and V. Cruz Machado. 2015. "Quantifying the Supply Chain Resilience." In H. Tozan, & A. Erturk (Eds.), *Applications of contemporary management approaches in supply chains*. ISBN: 978-953-51-2045-2.
- Bevilacqua, M., F. E. Ciarapica, and G. Marucci. 2017. "Supply Chain Resilience Triangle: The Study and

- Development of a Framework." *World Academy of Science, Engineering and Technology, International Journal of Social, Behavioral, Educational, Economic, Business and Industrial Engineering* 11 (8): 1923–1930.
- Bichou, K. 2008. "Security and Risk-Based Models in Shipping and Ports: Review and Critical Analysis." OECD/ITF Joint Transport Research Centre Discussion Paper.
- Bishop, P., and R. Bloomfield. 2000. "A Methodology for Safety Case Development." In *Safety and Reliability*. Vol. 20 No.1, pp 34–42. Taylor & Francis.London, UK
- Bruneau, M., S. E. Chang, R. T. Eguchi, G. C. Lee, T. D. O'Rourke, A. M. Reinhorn, M. Shinozuka, K. Tierney, W. A. Wallace, and D. Von Winterfeldt. 2003. "A Framework to Quantitatively Assess and Enhance the Seismic Resilience of Communities." *Earthquake Spectra* 19 (4): 733–752. doi:10.1193/1.1623497.
- Chopra, S., and M. S. Sodhi. 2004. "Managing Risk to Avoid Supply-Chain Breakdown." *MIT Sloan Management Review* 46 (1): 53. Massachusetts Institute of Technology, Cambridge, MA.
- Chopra, S., and M. S. Sodhi. 2014. "Reducing the Risk of Supply Chain Disruptions." *MIT Sloan Management Review* 55 (3): 73. Massachusetts Institute of Technology, Cambridge, MA.
- Christopher, M., and H. Peck. 2004. "Building the Resilient Supply Chain." *The International Journal of Logistics Management* 15 (2): 1–14. Emerald Group Publishing Limited. doi:10.1108/09574090410700275.
- D'Lima, M., and F. Medda. 2015. "A New Measure of Resilience: An Application to the London Underground." *Transportation Research Part A: Policy and Practice* 81:35–46. Elsevier.
- Day, J. M., I. Junglas, and L. Silva. 2009. "Information Flow Impediments in Disaster Relief Supply Chains." *Journal of the Association for Information Systems* 10 (8): 637. Association for Information Systems. doi:10.17705/1jais.00205.
- de Ruijter, A., and F. Guldenmund. 2016. "The Bowtie Method: A Review." *Safety Science* 88: 211–218. Elsevier. doi:10.1016/j.ssci.2016.03.001.
- Eisenhardt, K. M. 1989. "Building Theories from Case Study Research." *Academy of Management Review* 14 (4): 532–550. Academy of Management. doi:10.5465/amr.1989.4308385.
- EU Commission.2006. "Authorized Economic Operator–THE AEO COMPACT MODEL." *Working Document, TAXUD/2006/1452*. Brussels.
- Falasca, M., C. W. Zobel, and D. Cook. 2008. "A Decision Support Framework to Assess Supply Chain Resilience." In *Proceedings of the 5th International ISCRAM Conference*, 596–605,May, Washington, DC
- Fowler, T. G., and S. Eirik. 2000. "Modeling Ship Transportation Risk." *Risk Analysis* 20 (2): 225–244. Wiley Online Library. doi:10.1111/0272-4332.202022.
- Gjerdrum, D., and M. Peter. 2011. "The New International Standard on the Practice of Risk management–A Comparison of ISO 31000: 2009 and the COSO ERM Framework." *Risk Management* 31: 8–13.
- Henningsson, S., H. Z. Henriksen, B. D. Rukanova, and Y. H. Tan. 2016. "The Anatomy of Digital Trade Infrastructures." *Institutional Repository,TU Delft*.
- Hermans, L. M., and W. A. H. Thissen. 2009. "Actor Analysis Methods and Their Use for Public Policy Analysts." *European Journal of Operational Research* 196 (2): 808–818. Elsevier. doi:10.1016/j.ejor.2008.03.040.
- Hesketh, D. 2010. "Weaknesses in the Supply Chain: Who Packed the Box." *World Customs Journal* 4 (2): 3–20. Citeseer.
- Hevner, A. R., T. March Salvatore, J. Park, and S. Ram. 2004. "Design Science in Information Systems Research." *MIS Quarterly* 28 (1): 75–105. Springer. doi:10.2307/25148625.
- ISO. 2011. *ISO 28002:2011 - Security Management Systems for the Supply Chain – Development of Resilience in the Supply Chain – Requirements with Guidance for Use*. Geneva: International Organisation for Standards. <https://www.iso.org/standard/56087.html>.
- ISO/IEC. 2010. *ISO 31010: 2009: Risk Management–Risk Assessment Techniques, Vol. 2010E*. Brussels: CENELEC.
- Ivanov, D., and B. Sokolov. 2013. "Control and System-Theoretic Identification of the Supply Chain Dynamics Domain for Planning, Analysis and Adaptation of Performance under Uncertainty." *European Journal of Operational Research* 224 (2): 313–323. Elsevier. doi:10.1016/j.ejor.2012.08.021.
- Jüttner, U., and S. Maklan. 2011. "Supply Chain Resilience in the Global Financial Crisis: An Empirical Study." *Supply Chain Management: An International Journal* 16 (4): 246–259. Emerald Group Publishing Limited. doi:10.1108/13598541111139062.
- Jüttner, U., H. Peck, and M. Christopher. 2003. "Supply Chain Risk Management: Outlining an Agenda for Future Research." *International Journal of Logistics: Research and Applications* 6 (4): 197–210. Taylor & Francis. doi:10.1080/13675560310001627016.
- Kamrad, B., and S. Lele. 1998. "Production, Operating Risk and Market Uncertainty: A Valuation Perspective on Controlled Policies." *IIE Transactions* 30 (5): 455–468. Taylor & Francis. doi:10.1080/07408179808966486.
- Kelly, T. 2004. "A Systematic Approach to Safety Case Management." SAE Technical Paper.
- Klibi, W., and A. Martel. 2012. "Modeling Approaches for the Design of Resilient Supply Networks under Disruptions." *International Journal of Production Economics* 135 (2): 882–898. Elsevier. doi:10.1016/j.ijpe.2011.10.028.
- Klievink, B., E. Van Stijn, D. Hesketh, H. Aldewereld, S. Overbeek, F. Heijmann, and Y.-H. Tan. 2012. "Enhancing Visibility in International Supply Chains: The Data Pipeline Concept." *International Journal of Electronic Government Research (IJEGR)* 8 (4): 14–33. IGI Global. doi:10.4018/jejr.2012100102.
- Lee, W.-S., D. L. Grosh, F. A. Tillman, and C. H. Lie. 1985. "Fault Tree Analysis, Methods, and Applications □ A Review." *IEEE Transactions on Reliability* 34 (3): 194–203. IEEE. doi:10.1109/TR.1985.5222114.
- Lengnick-Hall, C. A., and T. E. Beck. 2005. "Adaptive Fit versus Robust Transformation: How Organizations Respond to Environmental Change." *Journal of Management* 31 (5): 738–757. Sage Publications Sage CA: Thousand Oaks, CA. doi:10.1177/0149206305279367.
- Lewis, M. A. 2003. "Cause, Consequence and Control: Towards a Theoretical and Practical Model of Operational Risk." *Journal of Operations Management* 21 (2): 205–224. Elsevier. doi:10.1016/S0272-6963(02)00071-2.
- Liu, J., Y.-H. Tan, and J. Hulstijn. 2009. "IT Enabled Risk Management for Taxation and Customs: The Case of AEO Assessment in the Netherlands." In *International Conference on Electronic Government* (pp. 376-387). Springer, Berlin, Heidelberg. .
- Manuj, I., and J. T. Mentzer. 2008. "Global Supply Chain Risk Management Strategies." *International Journal of Physical*



- Distribution & Logistics Management* 38 (3): 192–223. Emerald Group Publishing Limited.
- Marhavilas, P.-K., D. Koulouriotis, and V. Gemeni. 2011. "Risk Analysis and Assessment Methodologies in the Work Sites: On a Review, Classification and Comparative Study of the Scientific Literature of the Period 2000–2009." *Journal of Loss Prevention in the Process Industries* 24 (5): 477–523. Elsevier. doi:10.1016/j.jlp.2011.03.004.
- Martínez-Sala, A. S., E. Egea-López, F. García-Sánchez, and G.-H. Joan. 2009. "Tracking of Returnable Packaging and Transport Units with Active RFID in the Grocery Supply Chain." *Computers in Industry* 60 (3): 161–171. Elsevier. doi:10.1016/j.compind.2008.12.003.
- Martins, M. R., and M. C. Maturana. 2010. "Human Error Contribution in Collision and Grounding of Oil Tankers." *Risk Analysis* 30 (4): 674–698. Wiley Online Library. doi:10.1111/j.1539-6924.2010.01392.x.
- Miller, K. D. 1992. "A Framework for Integrated Risk Management in International Business." *Journal of International Business Studies* 23 (2): 311–331. Springer. doi:10.1057/palgrave.jibs.8490270.
- Mitchell, T., and K. Harris. 2012. "Resilience: A Risk Management Approach." *ODI Background Note*. Overseas Development Institute: London.
- Mokhtari, K., J. Ren, C. Roberts, and J. Wang. 2011. "Application of a Generic Bow-Tie Based Risk Analysis Framework on Risk Management of Sea Ports and Offshore Terminals." *Journal of Hazardous Materials* 192 (2): 465–475. Elsevier. doi:10.1016/j.jhazmat.2011.05.035.
- Mullai, A. 2006. *Risk Management System-Risk Assessment Frameworks and Techniques*. Vol. 5. Turku, Finland: DaGoB (Safe and Reliable Transport Chains of Dangerous Goods in the Baltic Sea Region) Project Office, Turku School of Economics.
- Norrman, A., and U. Jansson. 2004. "Ericsson's Proactive Supply Chain Risk Management Approach after a Serious Sub-Supplier Accident." *International Journal of Physical Distribution & Logistics Management* 34 (5): 434–456. Emerald Group Publishing Limited. doi:10.1108/09600030410545463.
- Pettit, T. J., K. L. Croxton, and J. Fiksel. 2013. "Ensuring Supply Chain Resilience: Development and Implementation of an Assessment Tool." *Journal of Business Logistics* 34 (1): 46–76. Wiley Online Library. doi:10.1111/jbl.12009.
- Preble, J. F. 1997. "Integrating the Crisis Management Perspective into the Strategic Management Process." *Journal of Management Studies* 34 (5): 769–791. Wiley Online Library. doi:10.1111/1467-6486.00071.
- Purdy, G. 2010. "ISO 31000: 2009—Setting a New Standard for Risk Management." *Risk Analysis* 30 (6): 881–886. Wiley Online Library. doi:10.1111/risk.2010.30.issue-6.
- Rose, A. 2007. "Economic Resilience to Natural and Man-Made Disasters: Multidisciplinary Origins and Contextual Dimensions." *Environmental Hazards* 7 (4): 383–398. Elsevier. doi:10.1016/j.envhaz.2007.10.001.
- Rosqvist, T., and R. Tuominen. 2004. "Qualification of Formal Safety Assessment: An Exploratory Study." *Safety Science* 42 (2): 99–120. Elsevier. doi:10.1016/S0925-7535(03)00005-5.
- Rukanova, B., Henriksen, H.Z., Henningsson, S. and Tan, Y.H., 2017, August. The anatomy of digital trade infrastructures. In *International Conference on Business Informatics Research* (pp. 184–198). Springer, Cham.
- Rukanova, B., Henriksen, H.Z., Henningsson, S. and Tan, Y.H., 2017, August. The anatomy of digital trade infrastructures. In *International Conference on Business Informatics Research* (pp. 184–198). Springer, Cham.
- Sheffi, Y., and J. B. Rice Jr. 2005. "A Supply Chain View of the Resilient Enterprise." *MIT Sloan Management Review* 47 (1): 41. Massachusetts Institute of Technology, Cambridge, MA.
- Slovic, P., M. L. Finucane, E. Peters, and D. G. MacGregor. 2004. "Risk as Analysis and Risk as Feelings: Some Thoughts about Affect, Reason, Risk, and Rationality." *Risk Analysis* 24 (2): 311–322. Wiley Online Library. doi:10.1111/j.0272-4332.2004.00433.x.
- Smith, D., and M. Fischbacher. 2009. "The Changing Nature of Risk and Risk Management: The Challenge of Borders, Uncertainty and Resilience." *Risk Management* 11 (1): 1–12. Springer. doi:10.1057/rm.2009.1.
- Soni, U., V. Jain, and S. Kumar. 2014. "Measuring Supply Chain Resilience Using a Deterministic Modeling Approach." *Computers & Industrial Engineering* 74: 11–25. Elsevier. doi:10.1016/j.cie.2014.04.019.
- Spiegler, V. L. M., M. M. Naim, and J. Wikner. 2012. "A Control Engineering Approach to the Assessment of Supply Chain Resilience." *International Journal of Production Research* 50 (21): 6162–6187. Taylor & Francis. doi:10.1080/00207543.2012.710764.
- Stevenson, M., and M. Spring. 2007. "Flexibility from a Supply Chain Perspective: Definition and Review." *International Journal of Operations & Production Management* 27 (7): 685–713. Emerald Group Publishing Limited. doi:10.1108/01443570710756956.
- Tummala, R., and T. Schoenherr. 2011. "Assessing and Managing Risks Using the Supply Chain Risk Management Process (SCRMP)." *Supply Chain Management: An International Journal* 16 (6): 474–483. Emerald Group Publishing Limited. doi:10.1108/13598541111171165.
- Urciuoli, L., & Hintsä, J. 2016. Differences in security risk perceptions between logistics companies and cargo owners. *The International Journal of Logistics Management*, 27 (2), 418–437.
- Urciuoli, L., S. Mohanty, J. Hintsä, and E. G. Boekesteijn. 2014. "The Resilience of Energy Supply Chains: A Multiple Case Study Approach on Oil and Gas Supply Chains to Europe." *Supply Chain Management: An International Journal* 19 (1): 46–63. Emerald Group Publishing Limited. doi:10.1108/SCM-09-2012-0307.
- Valikangas, L., 2010. *The resilient organization: How adaptive cultures thrive even when strategy fails* (p. 110). New York: McGraw-Hill.
- van Oosterhout, M. 2008. "Organizations and Flows in the Network."
- VAN OOSTERHOUT, M., 2008: "Organizations and Flows in the network". In van Baalen, P.; Zuidwijk, R.; van Nune, J.; Port Inter-Organizational information systems. Capabilities to service global supply chains, Foundations and Trends® in Technology, Information and Operations Management, vol. 2, n. 2–3: 93–102.
- Wagner, S. M., and C. Bode. 2008. "An Empirical Examination of Supply Chain Performance along Several Dimensions of

- Risk." *Journal of Business Logistics* 29 (1): 307–325. Wiley Online Library. doi:[10.1002/j.2158-1592.2008.tb00081.x](https://doi.org/10.1002/j.2158-1592.2008.tb00081.x).
- Walker, B., C. S. Holling, S. Carpenter, and A. Kinzig. 2004. "Resilience, Adaptability and Transformability in Social–Ecological Systems." *Ecology and Society* 9 (2). The Resilience Alliance. doi:[10.5751/ES-00650-090205](https://doi.org/10.5751/ES-00650-090205).
- Wieland, A., and C. M. Wallenburg. 2013. "The Influence of Relational Competencies on Supply Chain Resilience: A Relational View." *International Journal of Physical Distribution & Logistics Management* 43 (4): 300–320. Emerald Group Publishing Limited. doi:[10.1108/IJPDLM-08-2012-0243](https://doi.org/10.1108/IJPDLM-08-2012-0243).
- Willis, H. H., and D. S. Ortiz. 2004. *Evaluating the Security of the Global Containerized Supply Chain*. Santa Monica CA: Rand Corp.
- Wolfert, J., C. N. Verdouw, C. M. Verloop, and A. J. M. Beulens. 2010. "Organizing Information Integration in Agri-food—A Method Based on a Service-Oriented Architecture and Living Lab Approach." *Computers and Electronics in Agriculture* 70 (2): 389–405. Elsevier. doi:[10.1016/j.compag.2009.07.015](https://doi.org/10.1016/j.compag.2009.07.015).
- Yang, Z. L., S. Bonsall, and J. Wang. 2010. "Facilitating Uncertainty Treatment in the Risk Assessment of Container Supply Chains." *Journal of Marine Engineering & Technology* 9 (2): 23–36. Taylor & Francis. doi:[10.1080/20464177.2010.11020233](https://doi.org/10.1080/20464177.2010.11020233).
- Yin, R. K. 1994. *Case Study Research: Design and Methods*. Beverly Hills. London: Sage Publications Thousand Oaks.