

## Effects of cold recovery technology on the microbial drinking water quality in unchlorinated distribution systems

Ahmad, Jawairia Imtiaz; Liu, Gang; van der Wielen, Paul; Medema, Gertjan; van der Hoek, Jan Peter

**DOI**

[10.1016/j.envres.2020.109175](https://doi.org/10.1016/j.envres.2020.109175)

**Publication date**

2020

**Document Version**

Final published version

**Published in**

Environmental Research

**Citation (APA)**

Ahmad, J. I., Liu, G., van der Wielen, P., Medema, G., & van der Hoek, J. P. (2020). Effects of cold recovery technology on the microbial drinking water quality in unchlorinated distribution systems. *Environmental Research*, 183, Article 109175. <https://doi.org/10.1016/j.envres.2020.109175>

**Important note**

To cite this publication, please use the final published version (if applicable). Please check the document version above.

**Copyright**

Other than for strictly personal use, it is not permitted to download, forward or distribute the text or part of it, without the consent of the author(s) and/or copyright holder(s), unless the work is under an open content license such as Creative Commons.

**Takedown policy**

Please contact us and provide details if you believe this document breaches copyrights. We will remove access to the work immediately and investigate your claim.



# Effects of cold recovery technology on the microbial drinking water quality in unchlorinated distribution systems

Jawairia Imtiaz Ahmad<sup>a,e</sup>, Gang Liu<sup>a,b,\*</sup>, Paul W.J.J. van der Wielen<sup>c,f</sup>, Gertjan Medema<sup>a,c,g</sup>, Jan Peter van der Hoek<sup>a,d</sup>

<sup>a</sup> Sanitary Engineering, Department of Water Management, Faculty of Civil Engineering and Geosciences, Delft University of Technology, P.O. Box 5048, 2600GA, Delft, the Netherlands

<sup>b</sup> Key Laboratory of Drinking Water Science and Technology, Research Centre for Eco-Environmental Sciences, Chinese Academy of Sciences, Beijing, 100085, PR China

<sup>c</sup> KWR Watercycle Research Institute, P.O. Box 1072, 3430 BB, Nieuwegein, the Netherlands

<sup>d</sup> Waternet, Korte Ouderkerkerdijk 7, 1096 AC, Amsterdam, the Netherlands

<sup>e</sup> Institute of Environmental Sciences and Engineering, School of Civil and Environmental Engineering, National University of Science and Technology, H-12 Sector, Islamabad, Pakistan

<sup>f</sup> Laboratory of Microbiology, Wageningen University, P.O. Box 8033, 6700, EH, Wageningen, the Netherlands

<sup>g</sup> Michigan State University, 1405, S Harrison Rd East-Lansing, 48823, USA

## ARTICLE INFO

### Keywords:

Drinking water distribution system  
Microbial ecology  
Cold recovery  
Drinking water quality  
Biofilm  
Bacterial community  
Opportunistic pathogens

## ABSTRACT

Drinking water distribution systems (DWDSs) are used to supply hygienically safe and biologically stable water for human consumption. The potential of thermal energy recovery from drinking water has been explored recently to provide cooling for buildings. Yet, the effects of increased water temperature induced by this “cold recovery” on the water quality in DWDSs are not known. The objective of this study was to investigate the impact of cold recovery from DWDSs on the microbiological quality of drinking water. For this purpose, three pilot distribution systems were operated in parallel for 38 weeks. System 1 has an operational heat exchanger, mimicking the cold recovery system by maintaining the water temperature at 25 °C; system 2 operated with a non-operational heat exchanger and system 3 run without heat exchanger. The results showed no significant effects on drinking water quality: cell numbers and ATP concentrations remained around  $3.5 \times 10^5$  cells/ml and 4 ng ATP/l, comparable observed operational taxonomic units (OTUs) (~470–490) and similar Shannon indices (7.7–8.9). In the system with cold recovery, a higher relative abundance of *Pseudomonas* spp. and *Chryseobacterium* spp. was observed in the drinking water microbial community, but only when the cold recovery induced temperature difference ( $\Delta T$ ) was higher than 9 °C. In the 38 weeks’ old biofilm, higher ATP concentration (475 vs. 89 pg/cm<sup>2</sup>), lower diversity (observed OTUs: 88 vs.  $\geq 200$ ) and a different bacterial community composition (e.g. higher relative abundance of *Novosphingobium* spp.) were detected, which did not influence water quality. No impacts were observed for the selected opportunistic pathogens after introducing cold recovery. It is concluded that cold recovery does not affect bacterial water quality. Further investigation for a longer period is commended to understand the dynamic responses of biofilm to the increased temperature caused by cold recovery.

## 1. Introduction

Drinking water supply requires raw water abstraction and treatment, followed by storage, transport and distribution of finished water. The water treatment processes are selected and adopted to purify water for drinking purposes based on the quality of the incoming water and the quality standards of the drinking water to comply with (Elías-Maxil

et al., 2014; van der Hoek, 2012). Further, the produced drinking water is distributed through extended drinking water transport and distribution systems (DWDSs) (Prest et al., 2016a; van der Kooij and van der Wielen, 2014). Worldwide, the biological stability of drinking water is maintained either by limiting nutrient concentrations (Prest et al., 2016a) or by applying a disinfectant residual to minimize the regrowth of microorganisms (Berry et al., 2006).

\* Corresponding author. Key Laboratory of Drinking Water Science and Technology, Research Centre for Eco-Environmental Sciences, Chinese Academy of Sciences, Beijing, 100085, PR China.

E-mail addresses: [g.liu-1@tudelft.nl](mailto:g.liu-1@tudelft.nl), [gliu@rcees.ac.cn](mailto:gliu@rcees.ac.cn), [g.liu-1@tudelft.nl](mailto:g.liu-1@tudelft.nl) (G. Liu).

<https://doi.org/10.1016/j.envres.2020.109175>

Received 6 October 2019; Received in revised form 22 January 2020; Accepted 22 January 2020

Available online 23 January 2020

0013-9351/ © 2020 The Authors. Published by Elsevier Inc. This is an open access article under the CC BY license (<http://creativecommons.org/licenses/by/4.0/>).

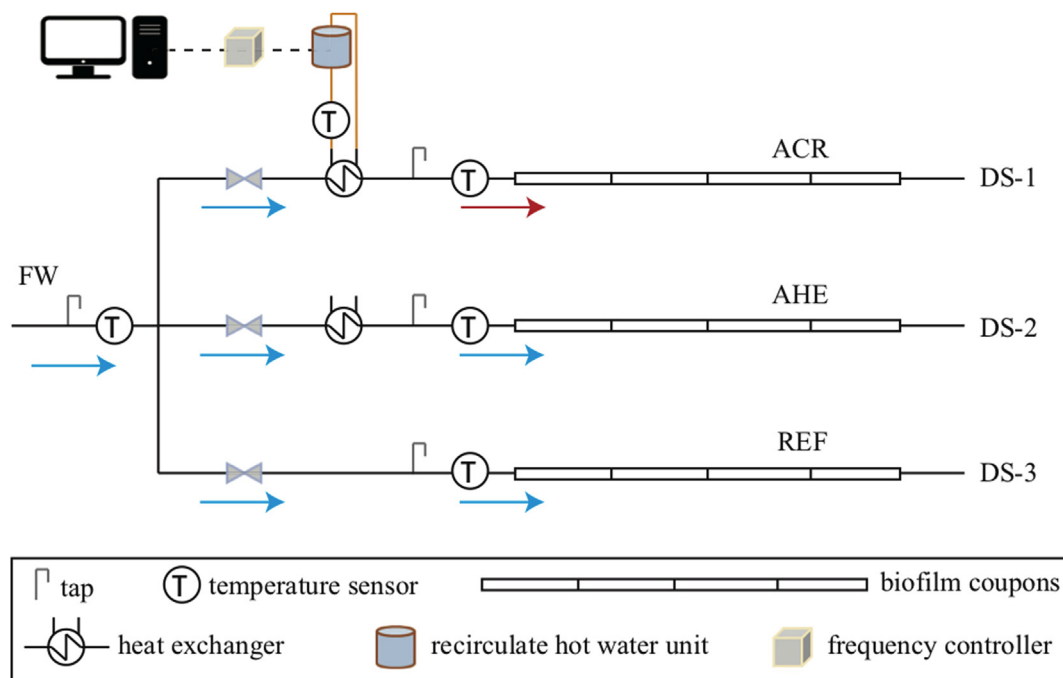

**Fig. 1.** Overview of the pilot facility consisting of three pilot distribution systems. DS-1: Cold recovery system; DS-2: System with non-operational Heat Exchanger (HE) and DS-3: Reference system. The overview shows the sampling locations (FW: Feed Water, ACR: After Cold Recovery, AHE: After the non-operational HE, REF: reference system), position of taps, coupons, HE (plate HE, where drinking water passes through the plates parallel to the plates with hot medium and absorb heat by heat transfer), recirculating hot water unit, temperature sensors and computer system connected with the experimental setup.

Drinking water supply requires energy for production and distribution purposes (e.g. overall between 4 and 13 MJ/m<sup>3</sup> in the Netherlands) (Gerbens-Leenes, 2016). Drinking water distribution systems also contain thermal energy as a surplus of cold or heat. For example, in the Netherlands, 1160 million m<sup>3</sup> of drinking water is distributed annually by 120,000 km long DWDSs (Frijns et al., 2013; Hofman et al., 2011; Liu et al., 2017b). The temperature within these DWDSs remains in general below 10 °C during winter which offers a potential for cold recovery, and above 15 °C during summer which offers a potential for heat recovery.

In the Netherlands, the potential of thermal energy from surface water, wastewater and drinking water has been analyzed. Of a future total heat demand in the build environment of 350 PJ per year, 40% can be covered by thermal energy from surface water, 16% by thermal energy from wastewater and 2% by thermal energy from drinking water (Kruit et al., 2018). For cooling purposes, thermal energy from surface water and drinking water may be attractive, although no extensive analysis has been made yet. In the case of Sanquin (full scale application of cold recovery, in Amsterdam, the Netherlands) for which location this study was based, thermal energy from drinking water was selected because supply (drinking water main) and demand (Sanquin) are located close to each other and surface water is not available nearby.

In Amsterdam (the Netherlands), the temperature within the DWDS is between 4 and 10 °C in winter and between 15 and 20 °C in summer. These temperatures offer possibilities to recover thermal energy by direct heat exchange: in case of cold recovery, drinking water exchanges its cold with a warm carrier medium (e.g. air, water, glycol, etc.) inside a heat exchanger and slightly heated water flows back into the DWDS (Blokker et al., 2013; van der Hoek, 2012; van der Hoek et al., 2017). According to a previous study, the theoretical thermal energy (cold recovery) potential for the city of Amsterdam is around 2800 TJ/year and an estimated energy required for space cooling for non residential buildings in Amsterdam is around 2161 TJ/year (Mol et al., 2011; van der Hoek et al., 2018). In this case DWDSs offer enough cooling capacity that can either be stored in aquifer thermal energy

storage (ATES) systems during the winters and that can be used in upcoming summers to provide space cooling, or utilized directly without intermediate storage during winters for facilities with extensive cooling requirements (e.g. blood banks, data centers, hospitals).

In principle, cold recovery from DWDSs is technically feasible, and environmentally and financially beneficial (van der Hoek et al., 2017). However, the temperature increase of drinking water due to cold recovery might influence the microbial activity and community of bacteria in bulk water and biofilm within DWDSs (Blokker et al., 2013; Elías-Maxil et al., 2014; van der Hoek, 2012). It is known that temperature changes can influence biological water quality, such as the reported seasonal fluctuations in adenosine triphosphate (ATP), total cell count (TCC) and changes in microbial community dynamics of bulk water (Hammes et al., 2008; Kelly et al., 2014; Liu et al., 2013a; Pinto et al., 2014; van der Wielen and van der Kooij, 2010). It has been documented that opportunistic pathogens (e.g. *Legionella pneumophila*, *Pseudomonas aeruginosa*, *Mycobacterium avium complex* and *Stenotrophomonas maltophilia*) could occur at temperatures above 25 °C (Tsao et al., 2019; van der Wielen et al., 2013) and biofilm growth could be accelerated at high temperatures (Boe-Hansen et al., 2002; Fish et al., 2016; Flemming and Wingender, 2010). However, the impact of energy recovery from drinking water on water quality is not well understood. Therefore, it is critical to assess the potential impact of increased water temperature, due to cold recovery, on the microbial water quality within drinking water distribution systems.

The main objective of this study is to investigate the effects of temperature increase induced by cold recovery on 1) biomass within DWDSs, quantified as ATP and TCC; 2) microbial community composition and diversity, profiled by illumina sequencing and 3) occurrence of selected opportunistic pathogens within DWDSs. Additionally, biofilms were also examined at the end of the experiments to assess potential impacts induced by cold recovery on biofilm.

## 2. Materials and methods

### 2.1. System description

#### 2.1.1. Pilot distribution systems

As illustrated in Fig. 1, three pilot scale distribution systems (DSs) were designed and operated in parallel from May to December 2016. The DSs were situated in the laboratory of TU Delft. They were supplied continuously with unchlorinated drinking water (referred as Feed Water) from treatment plant of Evides, Rotterdam, the Netherlands. Each of the experimental DSs had an internal diameter of 25 mm and a length of 10 m (residence time of water within DSs was 60 s), and was made of polyvinyl chloride-unplasticised (PVC-U) pipes. For this experiment the flow rate was set at 4.5 l/min (0.15 m/s), which is based on normal flow velocities within Dutch drinking water distribution systems. For water sampling, small taps of PVC-U were installed in each DSs. For biofilm sampling at the end of the study, from the pipe surface, 25 cm long PVC-U coupons were designed and inserted in all the three DSs: these are sections of pipes with valves on both ends. All the DSs were equipped with flow and temperature sensors, for continuously monitoring the flow and temperature of feed water and outgoing water. Dasy Lab software (version 13.0.1) was used for system monitoring and data logging.

#### 2.1.2. Design of operational heat exchanger system

Among the three DSs, DS-1 is the system that mimics cold recovery, which leads to an elevated drinking water temperature of 25 °C after passing the heat exchanger (HE). For this purpose a plate HE (Minex, SWEP, Sweden) was used (Table S1 A and S1 B) for the cold recovery to simulate the cold recovery situation at Sanquin project in Amsterdam, the Netherlands. Within the HE, on the plate surface heat is transferred between two fluids within a short time span (few seconds), cold (the drinking water under examination) and hot (recirculating water). The HE consists of 6 plates, 3 plates for hot recirculating medium, 2 plates for cold drinking water and 1 blank plate. After having passed the HE and having absorbed the heat to gain the set point temperature of 25 °C (which mimics the effect of cold recovery on the drinking water, which supplies cold with subsequent temperature increase), drinking water flows further through the main pipe and passes the whole length of DS-1. For recirculating heated water a hot tank (RVS boiler, AquaHeat, The Netherlands) along with a pump (Magna3, Grundfos, The Netherlands) and temperature sensor were connected with the hot channel of the HE. This setup was connected with a computer system through a frequency controller to further regulate the temperature on the HE surface, in order to maintain the threshold of 25 °C ( $T_{max}$ ) in drinking water leaving the HE after cold recovery. This set point,  $T_{max}$ , was maintained throughout the entire experimental period, irrespective of changes in the feed water temperature based on seasonal variations. The difference between the maximum temperature ( $T_{max}$ ) after cold recovery and Feed Water (FW) is referred here as  $\Delta T$ . During the current experimental period the  $\Delta T$  was between 5 and 18 °C (Figure S1 A).

#### 2.1.3. Reference and control systems

Similar to DS-1, DS-2 is the control system in which a non-operational heat exchanger was connected to the main pipe. In this control system, drinking water is passing the heat exchanger but no heating medium is flowing on the other side of the plates, thus water comes out of HE without temperature change. The control system is operated to reveal if the HE itself has any effects because of the different material (Tsvetanova and Hoekstra, 2010), the additional surface area and the different hydrodynamics ( $Re < 500$ ). DS-3 is the reference system in which no HE is placed, mimicking a Dutch non-chlorinated drinking water distribution system without cold recovery. Throughout this study, it was used as a reference to compare with the cold recovery system.

### 2.2. Sampling

Water samples were taken every 7 days during the experimental period from Feed Water (FW), after operational heat exchanger, where temperature of drinking water increased to 25 °C, mimicking cold recovery (ACR) (DS 1), after non-operational HE (AHE) (DS 2), and reference (REF) (DS3). After 38 weeks of experimental duration, biofilms were also sampled, in duplicate, from all three DSs (ACR, AHE and REF). For biofilm analysis, the valves on both sides of the pipe coupons were closed and the coupons were taken out of the systems and filled with DNA-free water (Thermo fisher scientific, Sweden). To remove the biofilm from the coupons, the pipe coupons were pretreated in 30 ml water by ultra-sonication, at a speed of 40 KHz, in a water bath (Ultrasonic 8800, Branson, USA) for 2 min. This sonication procedure was repeated for two additional times (Liu et al., 2014; Magic-Knezev and van der Kooij, 2004). The obtained suspension of 90 ml was used for further analysis. All microbiological analysis were performed within 24 h after sampling.

### 2.3. Quantification of biomass

#### 2.3.1. Adenosine triphosphate and total cell count

Bacterial cell numbers and active biomass were determined by measuring cell counts and the total adenosine triphosphate (ATP) concentration from both water samples ( $n = 104$ ) and biofilm samples ( $n = 6$ ). Cell counts were measured by a flow cytometer (C6-Flowcytometer, Accuri Cytometers, USA) using the same protocol that was previously developed and tested for drinking water samples (Prest et al., 2013). Total and membrane-intact cell counts were distinguished by adding two stains (SYBR Green 1 and propidium iodide) simultaneously as described by Prest et al. (2013). Active biomass was determined by measuring total ATP concentrations from both water and biofilm samples using a reagent kit for bacterial ATP and a luminometer (Celsis Advance Luminometer, Charles River, USA), as described previously (Liu et al., 2017a; Magic-Knezev and van der Kooij, 2004).

### 2.4. Microbial community composition and diversity

#### 2.4.1. DNA extraction and amplicon sequencing of 16 S rRNA genes

DNA was extracted from 104 water samples (2 L of water was filtered for each sample) and 6 biofilm samples, using a DNeasy PowerBiofilm kit (Qiagen, USA). Due to low amount of DNA ( $< 2 \mu\text{g/ml}$ ), 5 of the water samples were excluded for 16 S rRNA gene sequencing analysis and the duplicate biofilm samples were pooled together for achieving enough DNA to further process the samples for 16 S rRNA gene sequencing. For 16 S rRNA gene sequencing, the V3-V4 region of the 16 S rRNA gene was amplified using primers 341 F: 5'-CCTACGGGNGGCWGCAG-3' and 785 R: 5'-GACTACHVGGGTATCTAATCC-3' (Thijs et al., 2017). Paired-end sequence reads were generated using the Illumina MiSeq platform. FASTQ sequence files were generated using the Illumina Casava pipeline version 1.8.3. The initial quality assessment was based on data passing the Illumina Chastity filtering. Subsequently, reads containing the PhiX control signal were removed using an in-house filtering protocol at BaseClear laboratory, Leiden, the Netherlands. In addition, reads containing (partial) adapters were clipped (up to a minimum read length of 50bp). The second quality assessment was based on the remaining reads using the FASTQC quality control tool version 0.10.0. The final quality scores per sample were used further downstream to analyse Bioinformatics. All sequencing files were deposited in the sequence read archive (SRA) under accession number PRJNA475793.

#### 2.4.2. Data processing and statistical analysis

The obtained sequence libraries (which consisted of 4,945,856 sequences) after quality control from FASTQC were imported into the Quantitative Insights into Microbial Ecology (QIIME2) (version

2018.11) pipeline (Caporaso et al., 2010). The sequences were further screened, at the maximum length of 298 bp and minimum of 253 bp, denoised paired ends were merged and chimeras were removed using the inbuilt Divisive Amplicon Denoising Algorithm 2 (DADA2) (Callahan et al., 2016). The remaining representative sequences were clustered to operational taxonomic units (OTUs) at an identity of 97%. The sequences were normalized at sequence depth of 5532. For taxonomic assignment, feature-classifier plugin in QIIME2 was used against the SILVA database (132 release) for generating taxa bar plots and heat maps. Both, alpha (Shannon, Pielou's richness, observed OTUs) and beta (weighted UniFrac) diversity indices were calculated using phylogenetically based rooted tree (generated by aligning sequences using MAFFT plugin for phylogenetic reconstruction in FastTree), using QIIME2 diversity plugin. Further, Kruskal-Wallis (pairwise) test was performed on alpha diversity indices to determine the similarity/dissimilarity distances within the groups when data was divided based on locations and months (for water samples). The differences among different groups were determined by using quantitative beta diversity distance metrics (weighted UniFrac) and their statistical significance was calculated by performing permutational analysis of variance (PERMANOVA), with 999 permutations and using pairwise approach, to determine the effects of different groupings based on sampling location. Principal coordinate (PCO) plots were generated using weighted UniFrac distance in emperor plot plugin.

## 2.5. Identification of targeted microorganisms

### 2.5.1. *Legionella* spp.

Samples from both the water phase (only during months of June–August, for possible occurrence of *Legionella* within feed water) and the biofilm phase were tested for cultivable *Legionella* spp. The colony forming units (cfu) of *Legionella* spp. were determined using buffered charcoal yeast extract agar according to NEN standard 6265 (van der Wielen and van der Kooij, 2013). The positive and confirmed colonies of *Legionella* spp. were tested for presence of *Legionella pneumophila* or non-*pneumophila* species, with MALDITOF (Matrix Assisted Laser Desorption/Ionization Time of Flight Mass spectrometry) according to the protocol used at Het Waterlabortarium (HWL), Haarlem, the Netherlands (Dilger et al., 2016).

### 2.5.2. Quantitative polymerase chain reaction (qPCR)

The number of gene copies of the selected bacterial species (*Legionella anisa*, *Mycobacterium kansasii*, *Pseudomonas aeruginosa*, *Stenotrophomonas maltophilia* Chit A) and protozoan species (*Vermamoeba vermiformis*) were determined using quantitative PCR (qPCR). For all the 5 targeted species both water and biofilm samples were analyzed. The qPCRs used to quantify these species have been described previously (van der Wielen and van der Kooij, 2013). For each organism, targeted genes, primers, probes, and type of PCR, its protocols and amplification efficiency are given in Table S2 (> 84.0%). The qPCR results were only reported for samples that had a recovery efficiency higher than 20% based on an internal control as described previously (van der Wielen and van der Kooij, 2010).

## 3. Results

### 3.1. Microbial quantification

Cell counts and ATP concentrations in drinking water are shown in Fig. 2. Both ATP and cell counts showed comparable values among the distribution systems (DSs) (2–8 ng/l ATP, 2.0–6.5 × 10<sup>5</sup> cells/ml), indicating that the introduction of HE and increase in temperature has a minor influence on the concentration of planktonic bacteria and their activity in water. A clear seasonal trend was noticed in FW, showing higher cell numbers and ATP concentrations during summer (June to August) when the temperature of the incoming water is higher than

15 °C, than during the winter (Oct–Dec) when temperatures of the incoming water is lower than 15 °C. The ACR, AHE and REF systems did not influence this observed seasonal pattern in the water. Furthermore, the seasonal trend was also observed for the ATP concentrations measured in the water leaving the treatment plant (Fig. S1B).

In contrast to the water samples, 3.6–5.3 times more biofilm was formed after introducing cold recovery (ACR: 7.5 × 10<sup>6</sup> cells/cm<sup>2</sup>; 475 ATP pg/cm<sup>2</sup>) compared to biofilm formed without cold recovery after non-operational HE (AHE: 1.4 × 10<sup>6</sup> cells/cm<sup>2</sup>; 89 ATP pg/cm<sup>2</sup>) or the reference system (REF: 1.9 × 10<sup>6</sup> cells/cm<sup>2</sup>; 130 ATP pg/cm<sup>2</sup>) (Fig. 3). Moreover, the membrane-intact cell count in the biofilm from the ACR system (10<sup>6</sup> membrane-intact cells/cm<sup>2</sup>) was 10 times higher than in the biofilm from the other two systems (10<sup>5</sup> membrane-intact cells/cm<sup>2</sup>), whereas membrane-intact cell numbers were comparable for planktonic bacteria among all systems (Fig. S2).

### 3.2. Microbial community comparison

#### 3.2.1. Alpha diversity

In total, 1,565,519 sequences were generated after QIIME2 quality filtering process and these sequences have been assigned to 47,644 operational taxonomic units (OTUs). In bulk water, comparable numbers of OTUs were observed for FW (472 ± 128), ACR (476 ± 126), AHE (485 ± 136) and REF (481 ± 133). Although seasonal differences were observed and the number of observed OTUs, Shannon index and Pielou's evenness differed between different months, no differences were observed between different locations (Fig. S3). The months were grouped together based on the temperature of the feed water: the first group was from June to October (17–21 °C) and the second group consisted of May and December (14–16 °C). The differences in temperature between these two groups were statistically significant (Kruskal-Wallis, p < 0.05) (data not shown).

Fewer OTUs were observed in the biofilms (88–295 OTUs) compared to the number of observed OTUs in bulk water. For the biofilms formed in the systems without cold recovery, comparable numbers of OTUs were detected (295 and 288 OTUs for AHE and REF). Both are higher than the number of OTUs observed in the biofilm formed in the system with cold recovery (ACR, 88 OTUs). The results of the Shannon index (ACR: 4.2; AHE: 6.9; REF: 7.2) and Pielou's evenness (ACR: 0.64; AHE: 0.84; REF: 0.87) showed significant differences in alpha diversity between the systems with (ACR) and without (AHE and REF) cold recovery (Kruskal-Wallis, p < 0.05).

#### 3.2.2. Beta diversity

Results of bacterial community similarity analysis revealed different clusters for planktonic bacteria and biofilm (Fig. 4A), and these differences were also statistically significant (p < 0.05). Minor differences in bacterial community were found among water samples from all systems, while significant differences were observed among bacterial communities in the biofilm samples: the biofilm ACR clustered separately from the biofilms in AHE and REF systems, which clustered closely together. Comparing the water samples taken every month, the bacterial community composition of the samples were clustered based on seasonal variations corresponding to the microbial dynamics of the incoming drinking water (Fig. 4B). Water samples from each month clustered separately and these differences were significant (p < 0.05), as can also be seen by the percentage of variance explained by the two coordinates in Fig. 4B (21.3 and 14.0%, respectively). Furthermore, the differences between sampling locations were not significant (p > 0.05).

#### 3.2.3. Microbial community composition

For both planktonic bacteria and biofilm, the bacterial community was dominated by Proteobacteria at phylum level, with a relative abundance of 41–44% for water and 55–95% for biofilm, followed by the phyla of GN02 (8–9%), Planctomycetes (8%), Bacteroidetes (6–7%),



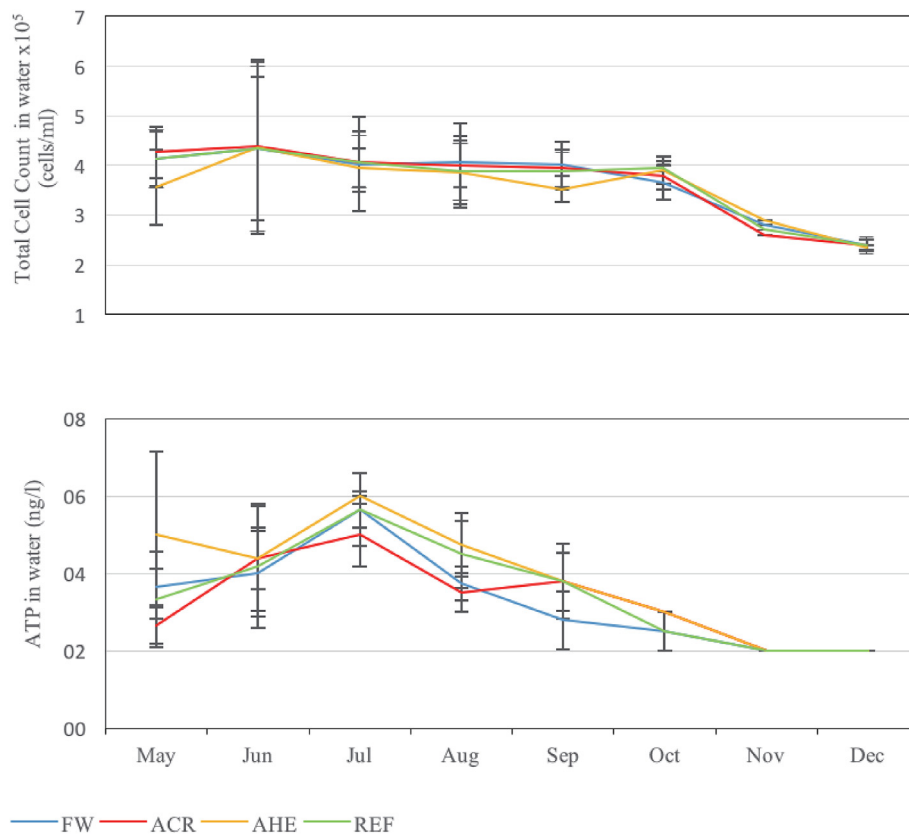

Fig. 2. Cell counts and ATP concentrations in water samples taken from the feed water and the three pilot drinking water distribution systems (FW: Feed Water; ACR: After Cold Recovery; AHE: After non-operational Heat Exchanger and REF: Reference).

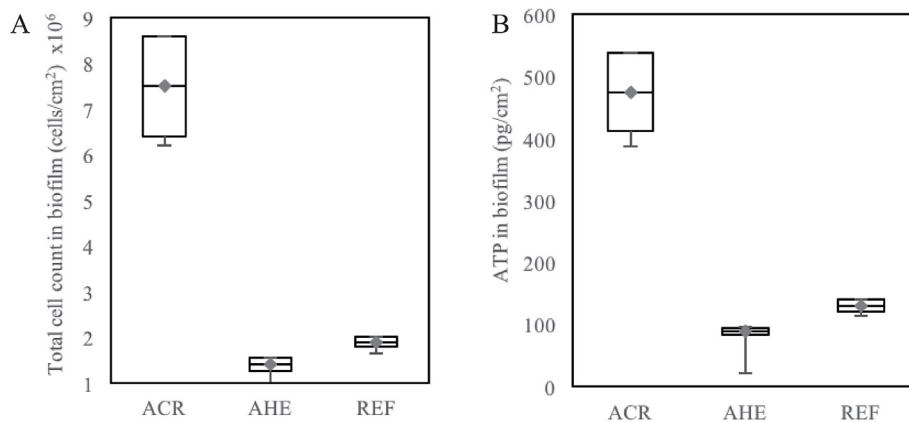

Fig. 3. Cell counts and ATP concentrations of biofilms sampled from the three pilot distribution systems with and without cold recovery (ACR: After Cold Recovery; AHE: After non-operational Heat Exchanger and REF: Reference).

OD1 (6–8%), and Cyanobacteria (1–2%) in water (Fig. 5A), and the phyla of Cyanobacteria (0.2–0.8%), OD1 (0.2–3%), Nitrospirae (0–3%), Chlamydiae (0–7%), Bacteroidetes (0.2–9%) and Planctomycetes (1–16%) in the biofilm (Fig. 5B).

No significant changes in microbial community composition were observed among the bulk water samples from different locations ( $p > 0.05$ ) but microbial composition differed significantly between months ( $p < 0.05$ ), which was similar to the results of the beta diversity analysis. At the class level, relative abundances of Alpha and Gammaproteobacteria were changing over the time period, where we observed  $> 11\%$  Gammaproteobacteria from June–October and  $< 11\%$  in the months of May and December. Comparable to this was the observation that  $> 20\%$  Alphaproteobacteria was found from June–August and  $< 20\%$  during months of May and from

Sep–December (Fig. S4A). In addition, the orders of Betaproteobacteriales, Pseudomonadales, Rhizobiales and Flavobacteriales were changing over the period of time as well. Higher relative abundance of Pseudomonadales and Flavobacteriales was observed after cold recovery compared to feed water and the other two locations (REF and AHE) (Fig. S4B). At the genus level, a higher relative abundance of *Pseudomonas* spp. (2.5%) and *Chryseobacterium* spp. (2.3%) was observed in the bulk water (Fig. S6) of the ACR system than in the other two systems (*Pseudomonas* spp in AHE: 0.5% and REF: 0.5%; *Chryseobacterium* spp 0.1% in both REF and AHE).

In the biofilm phase, the relative abundance of Proteobacteria was clearly higher in the ACR system (95.0%) than in the AHE (81.4%) and REF (57.5%) system. Also, at class level the relative abundances of Alpha and Gammaproteobacteria were higher in biofilm ACR (55% and

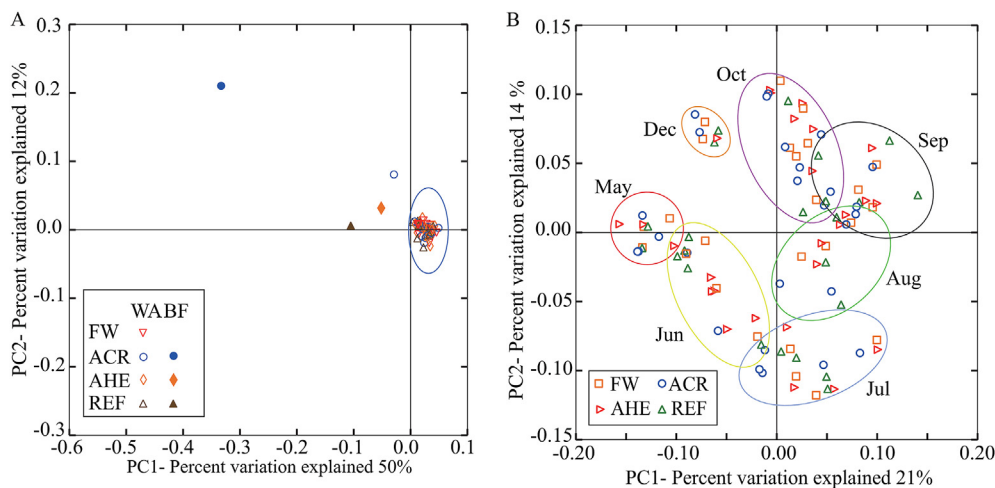

Fig. 4. PCoA plots based on weighted unifrac distance matrix, A) for both water (WA) and biofilm (BF) samples, and B) for only water samples. Samples from feed water and from the three pilot distribution systems: ACR, After Cold Recovery; AHE, After non-operational Heat Exchanger; REF, Reference and FW: Feed Water for only water phase.

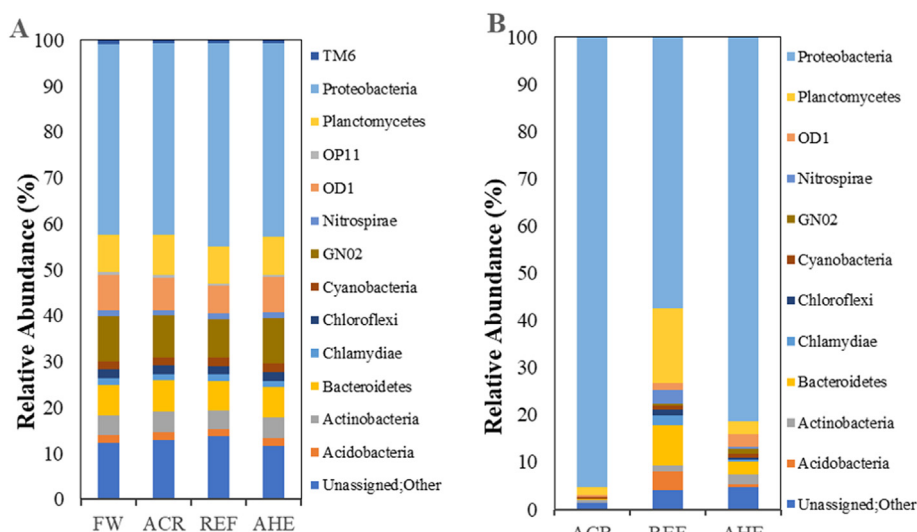

Fig. 5. Taxonomic composition for the identification of microbial community groups; at Phylum level, A) for water and B) for biofilm samples from the three pilot distribution systems (ACR: After Cold Recovery; AHE: After non-operational Heat Exchanger; REF: Reference and FW: Feed Water for only water phase).

27% respectively) compared to both biofilms without cold recovery situations, REF (37% and 22% respectively) and AHE (30% and 14% respectively). The orders of Pseudomonadales, Legionales and Sphingomonadales were also higher in abundance within ACR biofilm compared to other two locations without cold recovery (Fig. S5). Further, at genus level a higher relative abundance of *Novosphingobium* spp. (23.9%) and *Legionella* spp. (1.9%) was observed after introducing cold recovery (ACR system) compared to the AHE (0.2% *Novosphingobium* spp. and 0.03% *Legionella* spp.) and REF (0.02% *Novosphingobium* spp. and 0.01% *Legionella* spp.) systems (Fig. S6).

### 3.3. Opportunistic pathogens

In bulk water, 10–40% of the samples were positive for *Legionella* spp. (> 100 cfu/l, Fig. S7) across all systems, with no significant changes caused by applying cold recovery. In the biofilm phase, cultivable *Legionella* was detected in the REF system (3 cfu/cm<sup>2</sup>) (Table 1), but it was not detected from the ACR and AHE systems. The MALDITOF results revealed that the detected *Legionella* spp. colonies were not *L. pneumophila*.

q-PCR results showed that *L. anisa* was detected in all water samples with comparable numbers (2.6 × 10<sup>3</sup>–1.5 × 10<sup>4</sup> gene copies/l) between the systems (Fig. 6 A). In the biofilm, *L. anisa* was only detected in the biofilm formed in the system with cold recovery (ACR: 7 gene

Table 1

Colony forming units (cfu) of *Legionella* spp. and cell copies determined with qPCR, of targeted microbes in biofilm samples within pilot DWDSs, from all sampling locations (ACR: After Cold Recovery; AHE: After non-operational Heat Exchanger; REF: Reference; UD: under detection limit).

	ACR	AHE	REF
<i>Legionella</i> spp. (cfu/cm <sup>2</sup> )	0	0	3
<i>Legionella anisa</i> (copies/cm <sup>2</sup> )	7	UD	UD
<i>Vermamoeba vermiformis</i> (copies/cm <sup>2</sup> )	1.6 × 10 <sup>3</sup>	UD	UD
<i>Stenotrophomonas maltophilia</i> (copies/cm <sup>2</sup> )	UD	UD	3 × 10 <sup>1</sup>

copies/cm<sup>2</sup>) (Table 1). *V. vermiformis*, a host protozoan for *Legionella*, was also detected in all water samples at numbers between 3.5 × 10<sup>2</sup>–1.4 × 10<sup>3</sup> gene copies/l (Fig. 6 B). In the biofilm, *V. vermiformis* was detected in the system with cold recovery (ACR: 1.6 × 10<sup>3</sup> copies/cm<sup>2</sup>), but not in the systems without cold recovery (AHE, REF; Table 1).

Similarly, in all water samples *S. maltophilia* was detected with comparable concentrations, although they were slightly higher after applying cold recovery (ACR: 1.5 × 10<sup>3</sup>; AHE: 1.14 × 10<sup>3</sup>; REF: 2 × 10<sup>2</sup> gene copies/l; Fig. 6 C). In the biofilm, *S. maltophilia* was below the detection limit in all samples (Table 1). *Pseudomonas aeruginosa* and *Mycobacterium kansasii* were not detectable in all water and biofilm

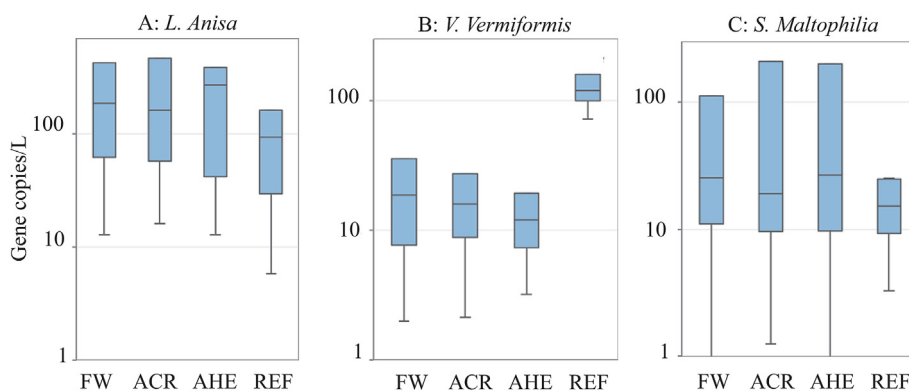

Fig. 6. Detection of selected microbes by qPCR. A) Gene copies of *Legionella anisa*, B) Genecopies of host protozoa *Vermamoeba vermiformis* and C) *Stenotrophomonas maltophilia*. The sampling locations for water are, FW: Feed Water; ACR: After Cold Recovery; AHE: After non-operational Heat Exchanger; REF: Reference.

samples.

## 4. Discussion

### 4.1. Effect of cold recovery on planktonic bacteria in drinking water

Generally, our data set revealed that introducing cold recovery technology in a pilot drinking water distribution system has minor influences on the quantity and community of planktonic microbes and the presence of selected opportunistic pathogens, thought temperature has been reported as important factor for microbes selection (Proctor et al., 2018) and microbial community assembly (Inkinen et al., 2016; Proctor et al., 2017). One example is the observed correlation between cell counts and seasonal temperature fluctuations (Fish et al., 2015; Henne et al., 2013; Lautenschlager et al., 2010; Liu et al., 2013b; Prest et al., 2016b). In our study, we also found seasonally triggered differences in drinking water microbiology, although the overall microbial active biomass (ATP) and cell numbers remain stable over the study period. However, changes were observed in microbial community composition, with certain microbial groups remaining higher in summer and relatively lower in abundance during times when temperature was lower than 14–15 °C. But, seasonal fluctuations change water temperatures for a long period, while in a cold recovery system, the water resided in the system, inside the HE, for a very short time, in this study only 60 s.

Interestingly, at the genus level, it was observed that the relative abundance of *Pseudomonas* spp. (from 0.5% to 2.5%) and *Chryseobacterium* spp. (from 0.1% to 2.3%) increased, but only when the temperature differences between feed water and water after cold recovery were higher than 9 °C, which was the case during spring and winter periods ( $\Delta T \geq 9$  °C). This is reasonable, because *Pseudomonas* spp. prefers to grow in warm tap water under oligotrophic conditions (Proctor et al., 2017). For the cold recovery system, the regrowth of *Pseudomonas* spp. might be triggered by the exposure to higher temperature on the surface of HE during winter season ( $\Delta T \geq 9$  °C). The optimal temperature for *Chryseobacterium* spp. growth is between 25 and 28 °C (Gallego et al., 2006). Our findings suggest that there are no significant effects of cold recovery on drinking water quality at the set temperature of 25 °C. Future research is needed to understand the potential impact of larger temperature differences/higher drinking water temperatures in cold recovery systems. On the basis of the seasonal change of the feed water microbiome in this study, it is desirable to continue investigating them when cold recovery technology is applied. For example, to define the threshold for drinking water temperature ( $T_{max}$ ) in distribution systems and the maximum temperature differences ( $\Delta T$ ).

### 4.2. Effect of cold recovery on biofilm bacteria

Compared to planktonic bacteria in drinking water, biofilms were more responsive to the increased temperature caused by cold recovery, which is plausible given the longer exposure time of the biofilm compared to that of bulk water (38 weeks vs. 60 s). Although there is no previous study regarding the effects of temperature changes on biofilm developed inside drinking water distribution systems, the significant impact of temperature on the physical structure, quantity and community of biofilm has been widely observed across other different aquatic systems, such as river sediment biofilm (Villanueva et al., 2011), sea water biofilm (Smale et al., 2017), biofilm/biofouling in membrane systems for water purification (Farhat et al., 2016) and biofilm in hot water premise plumbing systems (Proctor et al., 2017). The significant increase of biofilm concentration, at 38 weeks, after introducing cold recovery (5 times more ATP) is consistent with previous studies, which reported higher biofilm concentrations resulting from temperature increase, and concluded that bacterial growth kinetics were governed by temperature in the biofilm phase (van der Kooij and van der Wielen, 2014; Villanueva et al., 2011; Vital et al., 2010).

Similar to the quantitative results, significant changes in the bacterial community composition and diversity were observed, confirming the previously reported importance of temperature in structuring bacterial communities (Smale et al., 2017). This study found the system with cold recovery formed biofilm was less diverse in bacterial community than the other systems without cold recovery. The higher relative abundance of *Methylibium* spp., *Polaromonas* spp., *Leptothrix* spp., *Nitrospira* spp., *Pseudomonas* spp. and *Sphingomonas* spp. in the system without cold recovery corresponds to the early stage of biofilm development (Martiny et al., 2003; van der Kooij et al., 2018), while the less diversity, more *Novosphingobium* spp. and *Legionella* spp., less *Nitrospira* spp. and *Betaproteobacteriales* in the biofilm from the system with cold recovery agreed with later stage of biofilm development that was approaching a stabilized microbial community (Martiny et al., 2003). This may indicate that the biofilms in the system with and without cold recovery might at different stage of biofilm development due to the differences in temperature.

This shows that constantly stable and higher temperature inside the cold recovery system over the period of 38 weeks has selected for less diverse and more stable biofilm community composition compared to fluctuating temperatures inside the systems without cold recovery. However, in the present study the biofilm was sampled at the age of 38 weeks and the duplicate biofilm samples from all the three DSs showed good reproducibility in terms of microbial activity, as well as the results of biofilm samples from DSs without increase in temperature (REF and AHE) were highly similar. It is recommended to have long term studies following biofilm development dynamics to have a good understanding



on the effects of increased temperature induced by cold recovery. The present study demonstrated that the experimental setup is suitable and reliable for future long term studies.

#### 4.3. Practical implication and recommendations

The present study simulated the introduction of cold recovery into a drinking water distribution system that will increase the water temperature locally to 25 °C. According to the biomass concentrations and community compositions, no significant deterioration of microbial water quality was observed; though changes were found in the biofilms, there is no evidence of mass transfer between biofilm and bulk water causing any changes in microbial water quality irrespective of increased biofilm concentrations. The influence of the formed biofilm on the microbiological water quality needs to be studied on the long-term during the cold recovery process.

Regarding the presence of selected opportunistic pathogens in our study, under the conditions applied ( $\Delta T$  between 5 and 18 °C and a maximum temperature after cold recovery of 25 °C) and the feed water used, cold recovery does not pose a health risk. However, in the biofilm phase after cold recovery we did observe a higher concentration of *Legionella anisa* and its host protozoa, which indicates the potential growth of these temperature sensitive microbes in the biofilm phase. This needs further investigation in the biofilm phase (for example by inoculating the system with potential opportunistic pathogens) to see their behavior under different temperature settings (both  $\Delta T$  and maximum temperature after cold recovery).

For future research, besides the above recommendations of establishing temperature thresholds of  $T_{max}$  and  $\Delta T$  and conducting long term dynamic studies on biofilm development and water quality, it is recommended to investigate the contribution of nutrient levels on the effects of temperature increase and the response of an already established and old biofilm that has been developed over decades in distribution systems, to the sudden introduction of higher water temperature. A reason for this is that in a previous study it was found that the exposure to higher temperatures resulted in greater biofilm detachment (Fink et al., 2015). Therefore, it is important to study potential risks associated with such water temperature changes and subsequent biofilm detachment, which is the same as so called “transition effects” (Liu et al., 2017b; Chen et al., 2020).

The operational application of this concept in Amsterdam, the Netherlands, at a specific location (providing thermal energy for cooling to Sanquin, a company that produces products from blood plasma which requires a huge cooling capacity) is running with a temperature threshold of 15 °C as the maximum allowable drinking water temperature ( $T_{max}$ ) after cold recovery (van der Hoek et al., 2018). Based on further research on drinking water quality under various temperature profiles during cold recovery, it may be possible to push the upper temperature threshold higher (e.g. from the current 15 °C to the 25 °C in the Dutch water regulation) which will significantly enlarge the potential of energy that can be recovered. This will not only increase the potential of recoverable energy by increasing the  $\Delta T$ , but will also significantly extend the period over the year this concept can be operated.

## 5. Conclusions

From the perspectives of the bacterial quantity, community composition and the studied opportunistic pathogens, it is evident that our study showed minor effects of cold recovery on the bulk water. For the community composition of planktonic bacteria, cold recovery increased slightly the relative abundances of *Pseudomonas* spp. (0.4%–2.4%) and *Chryseobacterium* spp. (0.1%–2.1%). Regarding the selected microorganisms, increasing the temperature to 25 °C did not show any influence, except the slight increase of *S. maltophilia* gene copies ( $2 \times 10^2$  to  $1.5 \times 10^3$  gene copies/l). Some differences were observed between

the biofilm formed in the pilot distribution system with and without cold recovery (e.g. higher biomass and lower diversity of the community). A long term study (at least 2 years) on the potential influences of cold recovery on the dynamics of biofilm formation and detachments is highly recommended to have a solid understanding regarding the biofilm related processes after introducing cold recovery.

## Acknowledgment

The work was supported by Waternet, the water utility of Amsterdam and surroundings, and by the Topsector Water TKI Watertechnology Program (grant nr. 2015TUD003) of the Dutch Ministry of Economic Affairs and Climate Change. The authors would like to acknowledge the support from National Natural Science Foundation of China for International Cooperation and Exchange (51820105011), and for National Key R&D program (2018YFE0204100).

## Appendix A. Supplementary data

Supplementary data to this article can be found online at <https://doi.org/10.1016/j.envres.2020.109175>.

## References

- Berry, D., Xi, C., Raskin, L., 2006. Microbial ecology of drinking water distribution systems. *Curr. Opin. Biotechnol.* 17 (3), 297–302.
- Blokker, E.J.M., van Osch, A.M., Hogeveen, R., Mudde, C., 2013. Thermal energy from drinking water and cost benefit analysis for an entire city. *J. Water and Climate Change* 4 (1), 11–16.
- Boe-Hansen, R., Albrechtsen, H.J., Arvin, E., Jørgensen, C., 2002. Bulk water phase and biofilm growth in drinking water at low nutrient conditions. *Water Res.* 36 (18), 4477–4486.
- Callahan, B.J., McMurdie, P.J., Rosen, M.J., Han, A.W., Johnson, A.J.A., Holmes, S.P., 2016. DADA2: high-resolution sample inference from Illumina amplicon data. *Nat. Methods* 13, 581.
- Caporaso, J.G., Kuczynski, J., Stombaugh, J., Bittinger, K., Bushman, F.D., Costello, E.K., Fierer, N., Pêa, A.G., Goodrich, J.K., Gordon, J.I., Huttley, G.A., Kelley, S.T., Knights, D., Koenig, J.E., Ley, R.E., Lozupone, C.A., McDonald, D., Muegge, B.D., Pirrung, M., Reeder, J., Sevinsky, J.R., Turnbaugh, P.J., Walters, W.A., Widmann, J., Yatsunenkov, T., Zaneveld, J., Knight, R., 2010. QIIME allows analysis of high-throughput community sequencing data. *Nat. Methods* 7 (5), 335–336.
- Chen, L., Ling, F., Bakker, G., Liu, W.T., Medema, G., van der Meer, W., Liu, G., 2020. Assessing the transition effects in a drinking water distribution system caused by changing supply water quality: an indirect approach by characterizing suspended solids. *Water Res.* 168, 115159.
- Dilger, T., Melzl, J., Gessner, A., 2016. Rapid and reliable identification of waterborne *Legionella* species by MALDI-TOF mass spectrometry. *J. Microbiol. Methods* 127, 154–159.
- Elías-Maxil, J.A., van der Hoek, J.P., Hofman, J., Rietveld, L., 2014. Energy in the urban water cycle: actions to reduce the total expenditure of fossil fuels with emphasis on heat reclamation from urban water. *Renew. Sustain. Energy Rev.* 30, 808–820.
- Farhat, N., Vrouwenvelder, J.S., Van Loosdrecht, M., Bucs, S.S., Staal, M., 2016. Effect of water temperature on biofouling development in reverse osmosis membrane systems. *Water Res.* 103, 149–159.
- Fink, R., Oder, M., Rangus, D., Raspor, P., Bohinc, K., 2015. Microbial adhesion capacity. Influence of shear and temperature stress. *Int. J. Environ. Health Res.* 25 (6), 656–669.
- Fish, K.E., Collins, R., Green, N.H., Sharpe, R.L., Douterelo, I., Osborn, A.M., Boxall, J.B., 2015. Characterisation of the physical composition and microbial community structure of biofilms within a model full-scale drinking water distribution system. *PLoS One* 10 (2), e0115824.
- Fish, K.E., Osborn, A.M., Boxall, J., 2016. Characterising and understanding the impact of microbial biofilms and the extracellular polymeric substance (EPS) matrix in drinking water distribution systems. *Environ. Sci. J. Integr. Environ. Res.: Water Research & Technology* 2 (4), 614–630.
- Flemming, H.-C., Wingender, J., 2010. The biofilm matrix. *Nat. Rev. Microbiol.* 8 (9), 623–633.
- Frijns, J., Hofman, J., Nederlof, M., 2013. The potential of (waste)water as energy carrier. *Energy Convers. Manag.* 65, 357–363.
- Gallego, V., Garcia, M.T., Ventosa, A., 2006. *Chryseobacterium hispanicum* sp. nov., isolated from the drinking water distribution system of Sevilla, Spain. *Int. J. Syst. Evol. Microbiol.* 56 (Pt 7), 1589–1592.
- Gerbens-Leenes, P.W., 2016. Energy for freshwater supply, use and disposal in The Netherlands: a case study of Dutch households. *Int. J. Water Resour. Dev.* 32 (3), 398–411.
- Hammes, F., Berney, M., Wang, Y., Vital, M., Köster, O., Egli, T., 2008. Flow-cytometric total bacterial cell counts as a descriptive microbiological parameter for drinking

- water treatment processes. *Water Res.* 42 (1–2), 269–277.
- Henne, K., Kahlisch, L., Höfle, M.G., Brettar, I., 2013. Seasonal dynamics of bacterial community structure and composition in cold and hot drinking water derived from surface water reservoirs. *Water Res.* 47 (15), 5614–5630.
- Hofman, J., Hofman-Caris, R., Nederlof, M., Frijns, J., van Loosdrecht, M., 2011. Water and energy as inseparable twins for sustainable solutions. *Water Sci. Technol.* 63 (1), 88–92.
- Inkinen, J., Jayaprakash, B., Santo Domingo, J.W., Keinänen-Toivola, M.M., Ryu, H., Pitkänen, T., 2016. Diversity of ribosomal 16S DNA- and RNA-based bacterial community in an office building drinking water system. *J. Appl. Microbiol.* 120 (6), 1723–1738.
- Kelly, J.J., Minalt, N., Culotti, A., Pryor, M., Packman, A., 2014. Temporal variations in the abundance and composition of biofilm communities colonizing drinking water distribution pipes. *PLoS One* 9 (5), e98542.
- Kruit, K.S.B., Roosjen, R., Boderie, P., 2018. National Potential of Aquathermal Energy – Analysis and Review of Possibilities. (Delft, The Netherlands).
- Lautenschlager, K., Boon, N., Wang, Y., Egli, T., Hammes, F., 2010. Overnight stagnation of drinking water in household taps induces microbial growth and changes in community composition. *Water Res.* 44 (17), 4868–4877.
- Liu, G., Bakker, G.L., Li, S., Vreeburg, J.H.G., Verberk, J.Q.J.C., Medema, G.J., Liu, W.T., Van Dijk, J.C., 2014. Pyrosequencing reveals bacterial communities in unchlorinated drinking water distribution system: an integral study of bulk water, suspended solids, loose deposits, and pipe wall biofilm. *Environ. Sci. Technol.* 48 (10), 5467–5476.
- Liu, G., Ling, F., Magic-Knezev, A., Liu, W., Verberk, J.Q.J.C., Van Dijk, J.C., 2013a. Quantification and identification of particle associated bacteria in unchlorinated drinking water from three treatment plants by cultivation-independent methods. *Water Res.* 47 (10), 3523–3533.
- Liu, G., Tao, Y., Zhang, Y., Lut, M., Knibbe, W.-J., van der Wielen, P., Liu, W., Medema, G., van der Meer, W., 2017a. Hotspots for Selected Metal Elements and Microbes Accumulation and the Corresponding Water Quality Deterioration Potential in an Unchlorinated Drinking Water Distribution System. *Water Research*, pp. 435–445 124(Supplement C).
- Liu, G., Van der Mark, E.J., Verberk, J.Q.J.C., Van Dijk, J.C., 2013b. Flow Cytometry Total Cell Counts: A Field Study Assessing Microbiological Water Quality and Growth in Unchlorinated Drinking Water Distribution Systems. *BioMed Research International* 2013, 595872.
- Liu, G., Zhang, Y., Knibbe, W.-J., Feng, C., Liu, W., Medema, G., van der Meer, W., 2017b. Potential impacts of changing supply-water quality on drinking water distribution: a review. *Water Res.* 116, 135–148.
- Magic-Knezev, A., van der Kooij, D., 2004. Optimisation and significance of ATP analysis for measuring active biomass in granular activated carbon filters used in water treatment. *Water Res.* 38 (18), 3971–3979.
- Martiny, A.C., Jørgensen, T.M., Albrechtsen, H.-J., Arvin, E., Molin, S., 2003. Long-term succession of structure and diversity of a biofilm formed in a model drinking water distribution system. *Appl. Environ. Microbiol.* 69 (11), 6899–6907.
- Mol, S., Kornman, J., Kerpershoek, A., Van Der Helm, A., 2011. Opportunities for public water utilities in the market of energy from water. *Water Sci. Technol.* 63 (12).
- Pinto, A.J., Schroeder, J., Lunn, M., Sloan, W., Raskin, L., 2014. Spatial-temporal survey and occupancy-abundance modeling to predict bacterial community dynamics in the drinking water microbiome. *mBio* 5 (3) e01135-01114.
- Prest, E.I., Hammes, F., Kötzsch, S., van Loosdrecht, M.C.M., Vrouwenvelder, J.S., 2013. Monitoring microbiological changes in drinking water systems using a fast and reproducible flow cytometric method. *Water Res.* 47 (19), 7131–7142.
- Prest, E.I., Hammes, F., van Loosdrecht, M.C.M., Vrouwenvelder, J.S., 2016a. Biological stability of drinking water: controlling factors, methods, and challenges. *Front. Microbiol.* 7, 45.
- Prest, E.I., Weissbrodt, D.G., Hammes, F., van Loosdrecht, M.C.M., Vrouwenvelder, J.S., 2016b. Long-term bacterial dynamics in a full-scale drinking water distribution system. *PLoS One* 11 (10), e0164445.
- Proctor, C.R., Dai, D., Edwards, M.A., Pruden, A., 2017. Interactive effects of temperature, organic carbon, and pipe material on microbiota composition and *Legionella pneumophila* in hot water plumbing systems. *Microbiome* 5 (1), 130.
- Proctor, C.R., Reimann, M., Vriens, B., Hammes, F., 2018. Biofilms in shower hoses. *Water Res.* 131, 274–286.
- Smale, D.A., Taylor, J.D., Coombs, S.H., Moore, G., Cunliffe, M., 2017. Community responses to seawater warming are conserved across diverse biological groupings and taxonomic resolutions. *Proc. Biol. Sci.* 284 (1862), 20170534.
- Thijs, S., Op De Beeck, M., Beckers, B., Truyens, S., Stevens, V., Van Hamme, J.D., Weyens, N., Vangronsveld, J., 2017. Comparative evaluation of four bacteria-specific primer pairs for 16S rRNA gene surveys. *Front. Microbiol.* 8, 494.
- Tsao, H.-F., Scheikl, U., Herbold, C., Indra, A., Walochnik, J., Horn, M., 2019. The cooling tower water microbiota: seasonal dynamics and co-occurrence of bacterial and protist phylotypes. *Water Res.* 159, 464–479.
- Tsvetanova, Z.G., Hoekstra, E.J., 2010. The Effect of the Surface-To-Volume Contact Ratio on the Biomass Production Potential of the Pipe Products in Contact with Drinking Water. pp. 105–112.
- van der Hoek, J.P., 2012. Towards a climate neutral water cycle. *J. Water and Climate Change* 3 (3), 163–170.
- van der Hoek, J.P., Mol, S., Ahmad, J.I., Liu, G., Medema, G., 2017. In: Kroppe, J., A G O, Goričanec, D., Božičnik, S. (Eds.), *Thermal Energy Recovery from Drinking Water*. University of Maribor Press, Bled, Slovenia, pp. 23–32.
- van der Hoek, J.P., Mol, S., Giorgi, S., Ahmad, J.I., Liu, G., Medema, G., 2018. Energy recovery from the water cycle: thermal energy from drinking water. *Energy* 162, 977–987.
- van der Kooij, D., van der Wielen, P.W.J.J., 2014. In: van der Kooij, D., van der Wielen, P.W.J.J. (Eds.), *Microbial Growth in Drinking-Water Supplies: Problems, Causes, Control and Research Needs*. IWA Publishing, London, UK, pp. 1–20.
- van der Kooij, D., Veenendaal, H.R., Italiaander, R., van der Mark, E.J., Dignum, M., 2018. Primary colonizing Betaproteobacteriales play a key role in the growth of *Legionella pneumophila* in biofilms on surfaces exposed to drinking water treated by slow sand filtration. *Appl. Environ. Microbiol.* 84 (24) e01732-01718.
- van der Wielen, P.W.J.J., Italiaander, R., Wullings, B.A., Heijnen, L., van der Kooij, D., 2013. In: van der Kooij, D., van der Wielen, P.W.J.J. (Eds.), *Microbial Growth in Drinking-Water Supplies. Problems, Causes, Control and Research Needs*. IWA Publishing, London, UK, pp. 177–205.
- van der Wielen, P.W.J.J., van der Kooij, D., 2010. Effect of water composition, distance and season on the adenosine triphosphate concentration in unchlorinated drinking water in The Netherlands. *Water Res.* 44 (17), 4860–4867.
- van der Wielen, P.W.J.J., van der Kooij, D., 2013. Nontuberculous mycobacteria, fungi, and opportunistic pathogens in unchlorinated drinking water in The Netherlands. *Appl. Environ. Microbiol.* 79 (3), 825–834.
- Villanueva, V.D., Font, J., Schwartz, T., Romaní, A.M., 2011. Biofilm formation at warming temperature: acceleration of microbial colonization and microbial interactive effects. *Biofouling* 27 (1), 59–71.
- Vital, M., Stucki, D., Egli, T., Hammes, F., 2010. Evaluating the growth potential of pathogenic bacteria in water. *Appl. Environ. Microbiol.* 76 (19), 6477–6484.