

## Skin spectroscopy and imaging for cosmetics and dermatology

Ezerskaia, A.

**DOI**

[10.4233/uuid:d06dbc-dc-b1dc-4442-9862-9a3bf740203](https://doi.org/10.4233/uuid:d06dbc-dc-b1dc-4442-9862-9a3bf740203)

**Publication date**

2020

**Document Version**

Final published version

**Citation (APA)**

Ezerskaia, A. (2020). *Skin spectroscopy and imaging for cosmetics and dermatology*. [Dissertation (TU Delft), Delft University of Technology]. <https://doi.org/10.4233/uuid:d06dbc-dc-b1dc-4442-9862-9a3bf740203>

**Important note**

To cite this publication, please use the final published version (if applicable). Please check the document version above.

**Copyright**

Other than for strictly personal use, it is not permitted to download, forward or distribute the text or part of it, without the consent of the author(s) and/or copyright holder(s), unless the work is under an open content license such as Creative Commons.

**Takedown policy**

Please contact us and provide details if you believe this document breaches copyrights. We will remove access to the work immediately and investigate your claim.

# **SKIN SPECTROSCOPY AND IMAGING FOR COSMETICS AND DERMATOLOGY**

**Anna EZERSKAIA**

The work described was carried out at the Optics Research Group, Faculty of Applied Sciences, Delft University of Technology, P.O. Box 5046, 2600 GA Delft and at the Department of Personal Wellness and Care, Philips Research, HTC 11, 01, 5656 AE, Eindhoven, The Netherlands.

Ph.D Thesis, Delft University of Technology, Delft, The Netherlands, 2020  
With references – With summary in English and Dutch

Copyright © Anna Ezerskaia, 2020 All rights reserved.

Cover design by: Anna Ezerskaia

Front Cover illustration: The face depicts brick and mortar structure of stratum corneum in a symbolic manner. The plot represents absorption spectra of sebum and water – sebum in blue and water in orange.

Printed by IPSKAMP Printing, Auke Vleerstraat 145, 7547 PH, Enschede, The Netherlands.

ISBN: 978-94-6421-084-2

# **SKIN SPECTROSCOPY AND IMAGING FOR COSMETICS AND DERMATOLOGY**

## **DISSERTATION**

to obtain  
the doctor's degree at the Delft University of Technology,  
on the authority of the Rector Magnificus,  
Prof. Ir. T.H.J.J. van der Hagen,  
on account of the decision of the graduation committee,  
to be publicly defended  
on Wednesday, 28 October 2020 at 12.00 hrs.

by

**Anna EZERSKAIA**

Master of Science in Photonics,  
IMTO University<sup>1</sup> St. Petersburg, Russia  
geboren te Akhtubinsk, Rusland

---

<sup>1</sup>St. Petersburg National Research University of Information Technologies Mechanics & Optics

This dissertation has been approved by:

Promotor: Prof. dr. H.P. Urbach  
Promotor: Dr. S.F. Pereira

Composition of the doctoral committee:

Rector Magnificus, chairman  
Prof. dr. ir. W. Witteveen Technische Universiteit Delft

*Independent members:*

Prof. dr. I.A. Konyakhin ITMO University, Russia  
Prof. dr. H.J.C.M. Sterenborg Academic Medical Centre in Amsterdam  
(AMC), Netherlands  
Prof. dr. B.H.V. Hendriks Delft University of Technology and  
Philips Research  
Prof. dr. G.V. Vdovin Delft University of Technology

*Others members:*

Dr. Babu. Varghese, Philips Research



*Keywords:* Sebum, Skin hydration, Skin barrier function, Skin oiliness, Infrared spectroscopy, Hydration, Lipids, Tape stripping, Infrared spectroscopy, Gloss, Dermatology, Optical sensing, Specular and diffuse reflection.

*Printed by:* Ipskamp Printing B.V.

*Front & Back:* The face depicts brick and mortar structure of stratum corneum in a symbolic manner. The plot represents absorption spectra of sebum and water – sebum in blue and water in orange.

Copyright © 2020 by Anna Ezerskaia

ISBN: 978-94-6421-084-2

An electronic version of this dissertation is available at  
<http://repository.tudelft.nl/>.

*to Oksana*



# CONTENTS

<b>Summary</b>	<b>ix</b>
<b>Samenvatting</b>	<b>xi</b>
<b>1 Introduction</b>	<b>1</b>
1.1 Introduction . . . . .	1
1.2 Biology and morphology of the skin. . . . .	1
1.3 Skin structure . . . . .	1
1.3.1 Stratum basale . . . . .	2
1.3.2 Stratum spinosum . . . . .	2
1.3.3 Stratum granulosum . . . . .	2
1.3.4 Stratum corneum . . . . .	2
1.4 Skin oiliness: physiological function of sebaceous gland and sebum . . . . .	3
1.5 In-vivo skin hydration and oiliness measurements . . . . .	4
1.6 In-vivo skin gloss measurements . . . . .	13
1.7 Purpose of the research . . . . .	15
1.8 Outline of the thesis. . . . .	15
References . . . . .	16
<b>2 Quantitative and simultaneous non-invasive measurement of skin hydration and sebum levels*</b>	<b>21</b>
2.1 Introduction . . . . .	22
2.2 Materials and methods . . . . .	24
2.3 Results . . . . .	26
2.4 Discussion . . . . .	27
2.5 Conclusion . . . . .	30
References . . . . .	31
<b>3 Potential of short-wave infrared spectroscopy for quantitative, depth profiling of stratum corneum lipids and water in dermatology*</b>	<b>35</b>
3.1 Introduction . . . . .	36
3.1.1 Stratum corneum structure and composition . . . . .	36
3.1.2 Importance of skin barrier, lipids and water for cosmetic- and medical dermatology and skin pharmacology . . . . .	36
3.1.3 Need in quantification of skin barrier, lipids and water . . . . .	37
3.1.4 State of the art methods for quantification of skin lipids and water . . . . .	37
3.1.5 Short wave infrared spectroscopy for quantification of lipids and water in the stratum corneum . . . . .	38



3.2	Materials and methods . . . . .	39
3.3	Results . . . . .	40
3.4	Discussion . . . . .	44
3.5	Conclusion . . . . .	47
	References . . . . .	48
<b>4</b>	<b>High sensitivity optical measurement of skin gloss*</b>	<b>53</b>
4.1	Introduction . . . . .	54
4.2	Materials and methods . . . . .	55
4.2.1	Experimental set-up . . . . .	55
4.2.2	Monte Carlo simulations. . . . .	56
4.2.3	Image processing algorithms for gloss estimation . . . . .	56
4.2.4	Calibration using reference standards . . . . .	57
4.2.5	In-vivo skin gloss measurements. . . . .	58
4.3	Results . . . . .	58
4.3.1	Monte Carlo simulations. . . . .	58
4.3.2	Measurements on ISO gloss Calibration standards. . . . .	59
4.3.3	In-vivo skin gloss measurements. . . . .	59
4.4	Discussion . . . . .	61
4.5	Conclusion . . . . .	63
	References . . . . .	64
<b>5</b>	<b>Conclusions and outlook</b>	<b>67</b>
5.1	Conclusions. . . . .	68
5.2	Outlook . . . . .	69
	References . . . . .	71
	<b>Acknowledgements</b>	<b>75</b>
	<b>Curriculum Vitae</b>	<b>77</b>
	<b>List of Publications</b>	<b>81</b>

## SUMMARY

Skin is one of the most significant parts of the human body. It connects us with the environment and has a vast number of functions, among which defensive function is of a high importance. Skin structure and its layers may vary with a number of factors such as sight, age, sex, race and the overall health state of the individuals. The latter affects skin water to lipids ratio and their depth profile in the skin. Smaller changes in the water to lipids ratio may result in skin type variations. In both cases, skin appearance will change along with variations of skin conditions.

Given the great importance of the state of the skin, a number of methods and devices for measuring water and lipids content were developed over the years. The research presented in this thesis proposes methods to achieve simultaneous measurements of water and lipids content of the skin and their ratio. We also analysed the impact of these measurements on determining the skin condition. Skin appearance is also addressed through measurement of the skin gloss, using several methods such as the ratio of specular to diffuse component of the image, the slope of the gradient intensity of the image from specular to the diffuse component, and an approach based on number of weighted pixels.

The method proposed for simultaneous water and lipids content measurement is described in the Chapter 2, and is based on light measurements, comprising 3 wavelengths that are sensitive to primarily lipids, primarily water and equally sensitive to both, these wavelengths are: 1720 nm, 1770 nm, and 1750 nm, respectively. We benchmarked our measurement with those obtained with a corneometer and sebumeter – benchmark devices, on induced skin conditions corresponding to combinations of high, low and neutral levels of water and lipids content in the skin. The study showed good agreement.

The state of the protective function of stratum corneum (SC) and distribution as function of depth of skin lipids and water are addressed by means of short wave infrared spectroscopy. The method does not give information as a function of depth. This obstacle was overcome by tape stripping of one SC layer at a time. Comparative measurement was performed with Raman confocal microscopy and is described in the Chapter 3. Our proposed method showed similar pattern of the depth profile for water as obtained with the corneometer and with Raman confocal microscopy, while trans epidermal water loss measurement indicated the point of the barrier breaking point. Lipids measurements obtained with our method also showed similar trends as Raman confocal microscopy. As expected, water concentration increased and lipids concentration decreased with increasing depth into the stratum corneum.

Additionally, a low-cost method for quantifying skin appearance by measuring skin gloss is proposed in Chapter 4. The method has proven to be reliable for skin gloss measurements via comparison with benchmark devices, and it also shows a great potential for other gloss measurements in a wide range, i.e., from an almost absolutely matte surface to a mirror like one. The proposed method comprises surface imaging by hand-held low-cost camera with ring-illumination along with image post processing based on weighting specular and diffuse components of the image. A gloss value is assigned as the result of the processing.

Looking ahead, we discuss in Chapter 5 how the methods developed in this thesis could potentially be combined in one hand-held device. There will be several challenges such as the presence of other chromophores in the skin along with the low absorption coefficient of water and lipids in the spectral region suitable for the camera. The above-mentioned obstacles can be solved by measuring absorption and scattering coefficients separately by means of illumination with spatial frequency modulation. The presence of several chromophores will as well require separating their impact on the absorption coefficient, potentially using more extensive data processing algorithms than those used in this research.

## SAMENVATTING

De huid is een van de belangrijkste delen van het menselijk lichaam. Het verbindt ons met het milieu en heeft een groot aantal functies, waaronder de defensieve functie van groot belang is. De huidstructuur en de lagen kunnen variëren met een aantal factoren, zoals gezichtsvermogen, leeftijd, geslacht, ras en de algehele gezondheidstoestand van de persoon. Dit laatste heeft invloed op de verhouding tussen huidwater en lipiden en hun diepteprofiel in de huid. Kleinere veranderingen in de verhouding tussen water en lipiden kunnen leiden tot variaties in het huidtype. In beide gevallen verandert het uiterlijk van de huid samen met variaties in huidaanandoeningen.

Gezien het grote belang van de huidtoestand, zijn in de loop der jaren een aantal methoden en apparaten ontwikkeld om het water- en lipidengehalte te meten. Het hier gepresenteerde onderzoek stelt methoden voor om gelijktijdige metingen van het water- en lipidengehalte van de huid en hun verhouding te bereiken. We hebben ook de impact van deze metingen geanalyseerd om de huidconditie te bepalen. Het uiterlijk van de huid wordt ook aangepakt door meting van de huidglans, met behulp van verschillende methoden, zoals de verhouding tussen spiegelend en diffuus onderdeel van de afbeelding, helling van de gradiënt intensiteit van de afbeelding van spiegelend tot diffuus onderdeel en aantal gewogen pixels.

De voorgestelde methode voor gelijktijdige meting van water- en lipidengehalte wordt beschreven in hoofdstuk 2 en is gebaseerd op lichtmetingen, bestaande uit 3 golflengten die gevoelig zijn voor lipiden, water en even gevoelig voor beide – 1720 nm, 1770 nm en 1750 nm, respectievelijk. We vergeleken de resultaten van metingen, samen met Corneometer en Sebumeter – benchmarktoestellen, op geïnduceerde huidaanandoeningen die overeenkomen met combinaties van hoge, lage en neutrale niveaus van water en lipiden in de huid. Als resultaat wordt de glanswaarde vastgesteld.

Om de staat van de beschermende functie van de Stratum Corneum (SC) te controleren en de lipiden en het water in diepte profilering uit te drukken, wordt de methode van Nabij InfraRood Spectroscopie gebruikt. Deze methode beschikt niet over diepte resolutie. Dit obstakel werd overwonnen door tape stripping van de SC laag voor laag. Vergelijkende metingen werden uitgevoerd met Raman confocale microscopie en worden beschreven in hoofdstuk 3. Onze voorgestelde methode toonde een vergelijkbaar patroon van het diepteprofiel voor water aan als Corneometer en Raman confocale microscopie, terwijl de Trans Epidermaal Waterverlies meting het punt van het barrière breekpunt aangaf. Lipidenmetingen toonden ook vergelijkbare trends voor de voorgestelde methode in vergelijking met Raman confocale microscopie. Zoals verwacht nam de waterconcentratie toe en daalde de lipidenconcentratie binnen de diepte van het stratum corneum.

Bovendien wordt er een goedkope methode voorgesteld om de huidconditie in getallen uit te drukken door huidglansmetingen. Door vergelijking met het gebruik van de gouden standaard is deze methode betrouwbaar bewezen. De methode biedt ook mogelijkheden om een breed scala van oppervlaktes te meten van matte oppervlakken tot spiegeloppervlakken. De voorgelegde methode maakt gebruik van een goedkope handcamera met een ringverlichting en een beeldverwerking programma dat gerichte (spiegelende, glanzende) een diffuse reflectie met elkaar vergelijkt. De voorgestelde methode omvat oppervlaktebeeldvorming door een in de hand gehouden goedkope camera met ringverlichting, samen met de nabewerking van het beeld op basis van het wegen van spiegelende en diffuse componenten van het beeld. De glanswaarde wordt toegewezen als resultaat van de verwerking.

In hoofdstuk 5 worden verdere onderzoeksmogelijkheden beschreven naar aanleiding van de vondsten van dit proefschrift. Bijvoorbeeld, hoe de methoden die in dit proefschrift zijn ontwikkeld, mogelijk kunnen worden gecombineerd in één handapparaat. Er zullen verschillende uitdagingen zijn, zoals de aanwezigheid van andere chromoforen in de huid, samen met een lage absorptiecoëfficiënt van water en lipiden in het spectrale gebied dat geschikt is voor de camera. Bovengenoemde obstakels kunnen worden benaderd door absorptie- en verstrooiingscoëfficiënten afzonderlijk te meten door middel van verlichting met ruimtelijke frequentiemodulatie. De aanwezigheid van verschillende chromoforen zal ook het scheiden van hun impact op de absorptiecoëfficiënt vereisen, mogelijk met gebruikmaking van uitgebreidere gegevensverwerkingsalgoritmen dan degene die in dit onderzoek zijn gebruikt.

# 1

## INTRODUCTION

### 1.1. INTRODUCTION

Skin is the largest organ of human body, accounting for about 15% of the total body weight in adult humans [1]. The skin consists of three particular layers: hypodermis, dermis and epidermis.

### 1.2. BIOLOGY AND MORPHOLOGY OF THE SKIN

Hyperdermis is defined as the adipose tissue layer found between dermis and the aponeurosis and fasciae of the muscles. The thickness of hypodermis varies with anatomical site, age, sex, race, endocrine and nutritional status of the individual. Adipose tissue has small extracellular matrix compared to other connective tissues. Collagen fiber framework holds lipid filled cells (white adipocytes). One third of adipose tissue consists of mature adipocytes, the rest is composed by stromal-vascular cells including fibroblast, leukocytes, macrophages, and pre-adipocytes [2].

The dermis is highly vascularized and primarily consisting of connective tissue elements that is scantily populated with cells. Dermal adipose cells, mast cells, infiltrating leucocytes, sweat glands and pilo-sebaceous units are reported to be found in the dermis.

The epidermis mostly consists of keratinocytes, the rest includes melanocytes, Langerhans cells and Merkel cells. The epidermis is about 100-150  $\mu\text{m}$  thick and accumulates 20-30 ply. Epidermis can be divided on four distinct layers: stratum basale, stratum spinosum, stratum granulosum, and stratum corneum. The constant thickness and function of epidermis is maintained by continuous cell division in the basal layer [3].

### 1.3. SKIN STRUCTURE

Hypodermis consists of lipid rich clusters with variable diameter ranging between 30 and 70  $\mu\text{m}$ . Morphological structure of subcutaneous adipose tissue allows the overly-

ing skin to move as whole, both horizontally and vertically, and dispersion of externally applied pressure [4].

The dermis mainly consist of collagen fibers and can be divided into two anatomical regions: the papillary and reticular dermis. The papillary dermis is the thin (100-400  $\mu\text{m}$ ) outermost layer [5]. The reticular dermis is thicker (1-4 mm) inner layer of the dermis [6].

Epidermis is an outermost layer of the skin that separate body and ambience. Its thickness vary from body side to side in the range of 0.05 mm (eyelids) to 1.5 mm (palm). This layer consists of 4 layers as described below.

### 1.3.1. STRATUM BASALE

The *stratum basale* consists of epidermal stem cells and transiently amplifier cells derived from them.

### 1.3.2. STRATUM SPINOSUM

The *stratum spinosum* is abundantly populated by desmosomes. This layer shows common cells for Stratum basale combined with Odland bodies (lamellar bodies), keratinosomes, membrane-coating granules.

### 1.3.3. STRATUM GRANULOSUM

The *stratum granulosum* predominantly consists of keratohyalin granules, which consists of profillagrin, loricrin, cysteine-rich protein, keratin 1 and 10. Granules tend to enlarge in the upper layers of Stratum granulosum.

### 1.3.4. STRATUM CORNEUM

The *stratum corneum* can be shown as widely used brick & mortar organization [7], where corneocytes serve as bricks and lamellar bodies secreted content serves as mortar. Its structure may vary in dimensions, depending on body site and the location inside of the Stratum corneum. The barrier structure of the stratum corneum in human skin has four major components, from the inside of cornified cells to the outside: keratin/filaggrin and their degradation products filling the cytoplasm of cornified cells, the cornified cell envelope, the corneocyte lipid envelope and the intercellular lipid layers [7, 8]. The cornified lipid envelop and the intercellular lipid layers consists essentially of ultra-long-chain ceramides (~50%). They are of a specific composition required to form the highly ordered lipid lamellae, which are crucial for the barrier function. Other half of intercellular lipids mater of not least importance is shared between cholesterol (~25%), free fatty acids (~10-20%) and a fraction of phospholipids [9].

Next to the lipid matrix originating from lamella bodies of corneocytes, sebum secreted by sebaceous gland also contributes to the overall lipid profile at the surface of the stratum corneum [10].

The corneocytes of the stratum corneum contain not only insolubale components described above, but also soluble part called natural moisturizing factor (NMF), the main component binding water directly. NMF accounts for ~10-25% of the total dry weight for the stratum corneum [11].

The stratum corneum is thus a complex structure, which integrity and barrier function depend on cohesion of corneocytes, the presence and organization of lipids between them and their water-holding capacity.

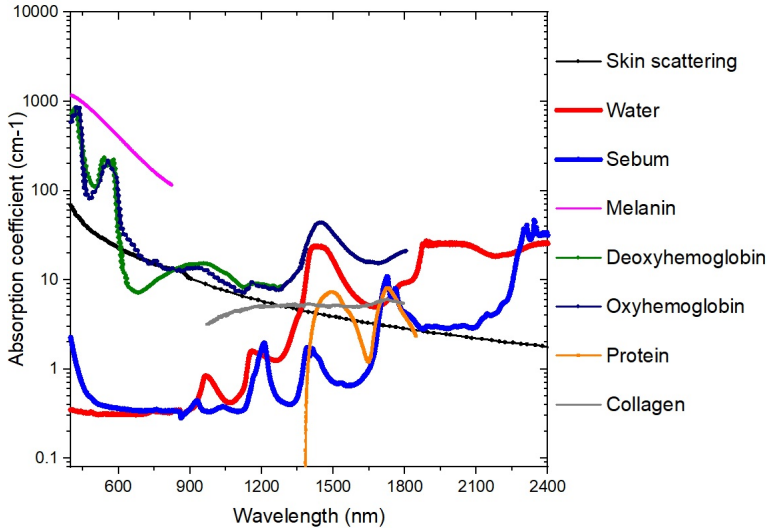
#### 1.4. SKIN OILINESS: PHYSIOLOGICAL FUNCTION OF SEBACEOUS GLAND AND SEBUM

Skin has broad range of functions to perform: thermoregulation, sensory function, endocrine function, communication function, etc. Among them the primary function is the protective one. It covers physical, biological, chemical, immune, pathogen, UV radiation and free radicals defense [12]. This protective barrier is mainly provided by Stratum corneum, where it is maintained by water-lipids bounding system [13].

Oily lipids secretory function is mainly associated with sebaceous glands, which usually are joined with hair follicle. A variety of functions had been assigned to human sebum; in addition to its protective function, it was considered to be anti-bacterial and anti-fungal and performs a role in the regulation of transepidermal water loss. Sebaceous glands vary in size and density of distribution depending on age, gender, physiological side, etc. and cover almost whole human body, except palms and soles [12].

Naturally, skin sebum and other lipids are linked to skin oiliness, which plays essential role together with skin hydration in skin integrity as well as in skin appearance. Skin glossiness, color, texture, radiance (balance of reflective and scattering properties), etc. are influential aspects in social life; they depend on several factors, and skin chromophores (Fig. 1.1) are on the top of the list. Where Figure (1.1) shows the wavelength dependent absorption coefficient of skin chromophores and skin scattering coefficient in the wavelength range from 400 - 2400 nm. The optical absorption properties of skin in the short wavelength region is primarily defined in terms of melanin and hemoglobin absorption proportional to the volume fractions of melanosomes and whole blood. The influence of these chromophores is expected to be lower in the infrared spectral range, where water and lipids are main absorbing chromophores. The skin scattering is described in terms of relative contributions of Mie and Rayleigh scattering due to collagen fibers in dermis. The epidermal scattering is close to that of dermal scattering and epidermal thickness is small to be not critical in light propagation. The skin colour mainly depends on melanin and blood [14, 15]. Skin coloration due to lesion or trauma (for example, a bruise) can cause yellow, blue, green, and other coloration which is stipulated by one or several chromophores like oxi-, deoxy-hemoglobin, heme, biliverdin, bilirubin, etc. [16]. Skin color can be affected also by skin hydration and texture by influencing skin scattering properties. For example, dry skin is characterized by dull color (usually gray-white), rough texture, and an elevated number of ridges [15].





**Figure 1.1:** Absorption spectra of skin chromophore: water, sebum [17, 18], skin scattering [19], collagen [20], blood [21], proteins [22] and melanin [23].

## 1.5. IN-VIVO SKIN HYDRATION AND OILINESS MEASUREMENTS

Characterization of the skin barrier is of central importance in several fields including dermatology, skin pharmacology and personal care. Skin barrier function is affected in patients with extensive list of dermatological diseases including lamellar ichthyosis, psoriasis, Netherton syndrome, Chanarin-Dorfman and atopic dermatitis (AD) [23].

Skin barrier abnormalities such as reduced structural proteins and lipids, altered composition of epidermal lipids and heterogeneity in lipid/protein composition at micrometer scale, changes in trans-epidermal water loss (TEWL) are observed in the majority of the known dermatological disorders [24]. The balance of water and lipids is a concern for personal care and cosmetic dermatology: alterations in skin water holding capacity, water and lipids concentrations are thought to be implicated in various skin conditions [25]. High importance of the water-lipids balance led to development of a series of measuring techniques and devices.

**Table 1.1:** Summary of the methods used for lipids detection

	<b>Measurement principle</b>	<b>Output</b>	<b>Probing depth</b>	<b>Advantages</b>	<b>Limitations</b>	<b>Invasive</b>	<b>Ref.</b>
<b>Photometry</b>	A probe containing an opaque plastic strip is pressed on the skin for 30 s. Amount of the absorbed by the strip sebum affects its transparency, this indicates the sebum level on the skin.	Lipids content on the skin surface, arbitrary units.	Superficial	Easy-to-use. Small-sized probes for measurement of body parts. Relatively inexpensive.	Influenced by environment and skin parameters.	No	[26]
<b>Gravimetry</b>	Generically method involves ether extraction of the sebum. There are also more direct methods by pre- and post-weighting.	Weight of extracted / absorbed lipids.	Superficial	Precise	Cumbersome	Yes	[27]
<b>Infrared spectroscopy</b>	The presence and amount of lipids is determined by spectral peaks (such as 1208, 1414, 1726, and 1758 nm) and their intensity measured with a calibrated spectrometer.	Intensity	Wavelength dependent in the range of 0.01 - 3 mm.	Wavelength dependent in the range of 0.01 - 3 mm.	Influenced by other present chromophores.	No	[28]

<b>Raman Confocal Spectroscopy</b>	The presence and amount of lipids is determined by corresponding Raman spectral lines (such as $2880\text{ cm}^{-1}$ ) and their intensity measured against reference line (usually protein - $2930\text{ cm}^{-1}$ ).	Intensity	$100\ \mu\text{m}$	Composition sensitive, precise, depth resolving.	Expensive	No	[29, 30]
<b>Electron paramagnetic resonance</b>	Electron paramagnetic measures the freedom of anisotropic molecular motion, and the polarity of the spin labeled molecule in a way similar to spectroscopy.	Intensity	0.1 - 7 cm	Sensitive to structural changes of molecules. High spatial resolution.	Not sensitive to non-resonant absorption alike water molecular absorption of microwaves.	No	[31]
<b>X-ray</b>	Lipids are extracted by solvents. Lipid's structure is reconstructed from x-ray diffraction pattern.	Diffraction pattern	1 - 100 cm depends on energy	Enables retrieve structural information.	Cumbersome	Yes	[32]

<b>SWIR spectroscopy</b> <sup>1</sup>	Uses differential approach: relies on ratio of absorption of lipids to water, then individual absorption lines. Amount of lipids is retrieved from intensity of characteristic lines of lipid/water absorption ratio, such as 1720 nm (ratio ~ 2) and 1770 nm (ratio ~ 0.5).	Intensity	~ 350 $\mu\text{m}$	Simultaneous measurement of lipids and water.	Can be influenced by other present chromophores.	No	[33]
---------------------------------------	--	-----------	---------------------	---	--	----	------

---

<sup>1</sup>This is the proposed method.

**Table 1.2:** Summary of the methods used for water detection

	<b>Measurement principle</b>	<b>Output</b>	<b>Probing depth</b>	<b>Advantages</b>	<b>Limitations</b>	<b>Invasive</b>	<b>Ref.</b>
<b>Capacitance</b>	Capacitance based measurements assuming dielectric constant of water 81 and the rest of the skin < 7.	Hydration of the skin surface expressed in arbitrary units of the device.	20 - 45 $\mu\text{m}$	Easy-to-use small-sized probes for measurement of body parts. Relatively inexpensive.	Influenced by environment and skin parameters Sensitive to repetitive measurements in the same area. Pressure sensitive.	No	[34]
<b>Raman Confocal Spectroscopy</b>	The presence and amount of water is determined by corresponding Raman spectral lines (such as $3350\text{ cm}^{-1}$ - $3550\text{ cm}^{-1}$ - water) and their intensity measured against reference line: $2930\text{ cm}^{-1}$ - protein).	Intensity	Adjustable, depends on wavelength, 1 - $5000\text{ }\mu\text{m}$	Composition sensitive, precise, depth resolving.	Expensive	No	[35-37]
<b>Conductance</b>	The principle is based on conductance method, operating at a single frequency (3.5 MHz).	Electric conductance	15 $\mu\text{m}$	Easy-to-use small-sized probes for measurement of body parts.	Influenced by environment and skin parameters. Sensitive to repetitive measurements in the same area.	No	[38]

<b>Capacitance mapping</b>	Mapping of dielectric permittivity, similar to the principle used in capacitive fingerprint sensing	Dielectric permittivity.	20 $\mu\text{m}$	Easy-to-use small-sized probes with and option of recording 2-d map of the skin hydration.	Pressure sensitive.	No	[39]
<b>Infrared spectroscopy</b>	The presence and amount of water is determined by spectral peaks (such as 970, 1450, 1950 nm, etc.) and their intensity measured with a calibrated spectrometer.	Intensity	Wavelength dependent in the range of 0.01 - 3 mm.	Composition sensitive.	Influenced by other present chromophores.	No	[40]
<b>TEWL</b>	Flux of evaporated fluids from skin is measured as indication of trans epidermal water loss.	Flux	Superficial	Easy-to-use small-sized probes for measurement of body parts. Relatively inexpensive.	Easy-to-use small-sized probes for measurement of body parts. Relatively inexpensive.	No	[41, 42]

<b>Impedance</b>	Impedance-based measurement principle.	Impedance	$\sim 20 \mu\text{m}$	Easy-to-use small-sized probes for measurement of body parts. Relatively inexpensive.	Influenced by environment and skin parameters. Sensitive to repetitive measurements in the same area.	No	[43, 44]
<b>SWIR spectroscopy<sup>1</sup></b>	Uses differential approach: relies on ratio of absorption of lipids to water, then individual absorption lines. Amount of water is retrieved from intensity of characteristic lines of lipid/water absorption ratio, such as 1720 nm (ratio $\sim 2$ ) and 1770 nm (ratio $\sim 0.5$ ).	Intensity	$\sim 350 \mu\text{m}$	Simultaneous measurement of lipids and water.	Can be influenced by other present chromophores.	No	[33]

**Table 1.3:** Summary of the depth profile measurements.

	<b>Measurement principle</b>	<b>Output</b>	<b>Probing depth</b>	<b>Advantages</b>	<b>Limitations</b>	<b>Invasive</b>	<b>Ref.</b>
<b>Raman Confocal Spectroscopy</b>	The presence and amount of lipids and/or water is determined by corresponding Raman spectral lines (such as 2880 $\text{cm}^{-1}$ - lipids and 3350 $\text{cm}^{-1}$ - 3550 $\text{cm}^{-1}$ - water) and their intensity measured as a ratio to reference line (usually protein - 2930 $\text{cm}^{-1}$ ) on the certain depth provided by the confocal method.	Intensity	100 $\mu\text{m}$	Composition sensitive, precise, depth resolving.	Expensive	No	[37, 45–48, 48]
<b>Confocal Spectroscopy</b>	Image is reconstructed from detected light spatially filtered with a pinhole light coming from the focal point on the measured object. The presence and amount of substance of interest is determined by spectral peaks and their intensity.	Intensity	100 $\mu\text{m}$	Composition sensitive, high resolution.	Influenced by other present chromophores.	No	[49]



<b>SWIR spectroscopy</b> <sup>1</sup>	Uses differential approach: relies on ratio of absorption of lipids to water, then individual absorption lines. Amount of lipids is retrieved from intensity of characteristic lines of lipid/water absorption ratio, such as 1720 nm (ratio ~ 2) and 1770 nm (ratio ~ 0.5). The depth resolution is provided by stripping 1 layer of stratum corneum with tapes at the time.	Intensity	Adjustable, 1 $\mu\text{m}$ to depth of penetration.	Composition sensitive, high resolution.	Influenced by other present chromophores.	No	<a href="#">[50]</a>
---------------------------------------	---	-----------	--	---	---	----	----------------------

## 1.6. IN-VIVO SKIN GLOSS MEASUREMENTS

Skin refractive index and texture are influenced by internal and external factors such as skin hydration and amount of superficial lipids as well as environmental conditions and the air pollution level [51]. The market of professional skin gloss measurement devices offers limited choice and is represented by devices based on intensity measurement or differential polarisation measurements (Table 1.4). The visual grading method remains the main tool for evaluating gloss attributes [52]. Apart from above mentioned methods, we describe two recently reported methods for human skin gloss measurements based on the ratio of specular to diffuse intensity and gradient of the intensity change from specular to diffuse reflection of the skin.

**Table 1.4:** Summary of the skin gloss measurements.

	<b>Measurement principle</b>	<b>Output</b>	<b>Advantages</b>	<b>Limitations</b>	<b>Invasive</b>	<b>Ref.</b>
<b>Photometry</b>	Measurement is based on detection intensity of directly (specular) reflected light with a correction of diffuse reflected light intensity.	Dimensionless quantity.	Fast, relatively inexpensive, easy-to-use.	Contact measurement, color influence.	No	[53, 54]
<b>Differential polarization imaging</b>	Differential polarization measurement. Differential image is converted to gray scale and pixel values of the region of interest are summed up.	Dimensionless quantity.	Fast, precise, reproducible, allows large area measurement.	Expensive	No	[52]
<b>Angle/slope approach</b>	Measurement is based on steepness of the intensity gradient slope in the 2-d image of the area of the interest.	Angle	Fast, relatively inexpensive, easy-to-use	Contact measurement, color influence.	No	[51]
<b>Specular/diffuse ratio approach</b>	Measurement is based on detection intensity of the ratio of specular reflected light intensity to diffuse reflected light intensity.	Dimensionless quantity	Fast, relatively inexpensive, easy-to-use	Contact measurement, color influence.	No	[51]

## 1.7. PURPOSE OF THE RESEARCH

In spite of many technological developments throughout the years, until now no non-contact devices and methods have been reported for the quantitative and simultaneous measurement of skin superficial lipids and water. Development of a non-contact method for measuring skin hydration and sebum simultaneously will enable to assess the balance between these factors related to skin health and to select the appropriate skin care treatment and products and will make it possible to monitor the progress during treatment [55]. Not least important is the assessment of the skin appearance for dermatological or cosmetological purposes [56]. Proposed quantitative assessment of the appearance of human skin resulting from complex optical interactions involving surface specular and subsurface diffuse reflections enables quantitative skin gloss assessment [51].

## 1.8. OUTLINE OF THE THESIS

**Chapter 2** is dedicated to a noninvasive infrared spectroscopic method comprising three wavelengths (1720 nm, 1750 nm and 1770 nm) for simultaneous detection of the skin lipids and hydration levels and comparison with a benchmark devices (Sebumeter and Corneometer, correspondingly) in-vivo for a number of skin types.

**Chapter 3** addresses the stratum corneum lipid and water profiles by means of infrared spectroscopy (depth profiling is realised via tape stripping), Raman confocal microscopy, and conventional devices for skin lipids (Sebumeter) and hydration (Corneometer) measurements in conjunction with TEWL measurement. IR spectroscopic method showed superior potential for the depth profile measurement employing tape stripping in comparison with conventional devices due to method intrinsic sensitivity and specificity.

**Chapter 4** proposes a low-cost method for measuring the gloss properties with improved sensitivity in the low gloss regime, relevant for skin gloss properties. The comparison with conventional methods (comprised in devices) is presented and shows a great potential for the proposed method in the niche of skin gloss measurement as well as other types of gloss measurements due to the method's performance sensitivity in a large range of gloss values. The proposed method is shown to be feasible for skin gloss kinetics measurements in-vivo.

Finally, **Chapter 5** describes a summary of the results of this research project and discusses the future applications and potentials of the results described in this thesis.

## REFERENCES

- [1] J. Kanitakis, *Anatomy, histology and immunohistochemistry of normal human skin*, European journal of dermatology **12**, 390 (2002).
- [2] W. Kim, B. Park, J. Sung, J. Yang, S. Park, S. Kwak, and P. J., *Wound healing effect of adipose-derived stem cells: A critical role of secretory factors on human dermal fibroblasts*, Journal of Dermatological Science **48**, 15 (2007).
- [3] A. Slominski, P. Manna, and R. Tuckey, *On the role of skin in the regulation of local and systemic steroidogenic activities*, Steroids **103**, 72 (2015).
- [4] A. Sbarbati, D. Accorsi, D. Benati, L. Marchetti, G. Orsini, G. Rigotti, and P. Panetiere, *Subcutaneous adipose tissue classification*, Eur J Histochem **54**, e48 (2010).
- [5] F. Silver, J. Freeman, and D. DeVore, *Viscoelastic properties of human skin and processed dermis*, Skin Res Technol **7**, 18 (2001).
- [6] N. Krejci, C. Cuono, R. Landon, and J. McGuire, *In vitro reconstitution of skin: Fibroblasts facilitate keratinocyte growth and differentiation on acellular reticular dermis*, Journal of Investigative Dermatology **97**, 843 (1991).
- [7] G. Menon, G. Cleary, and M. Lane, *The structure and function of the stratum corneum*, International Journal of Pharmaceutics **435**, 3 (2012).
- [8] C. Harding and R. Clive, *The stratum corneum: structure and function in health and disease*, Dermatologic Therapy **17**, 6 (2004).
- [9] D. Swartzendruber, P. Wertz, D. Kitko, K. Madison, M. Donald, and T. Downing, *Molecular models of the intercellular lipid lamellae in mammalian stratum corneum*, Journal of Investigative Dermatology **92**, 251 (1989).
- [10] N. K. Brogden, L. Mehalick, C. L. Fischer, P. W. Wertz, and K. A. Brogden, *The emerging role of peptides and lipids as antimicrobial epidermal barriers and modulators of local inflammation*, Skin Pharmacol Physiol **25**, 167 (2012).
- [11] A. Watabe, T. Sugawara, K. Kikuchi, K. Yamasaki, S. Sakai, and S. Aiba, *Sweat constitutes several natural moisturizing factors, lactate, urea, sodium, and potassium*, Journal of Dermatological Science **72**, 177 (2013).
- [12] V. R. Wheatley, *The sebaceous glands*, The physiology and pathophysiology of the skin, vol 9, A. Jarrett, ed. (1986).
- [13] P. Elias, *Stratum corneum defensive functions: An integrated view*, Journal of General Internal Medicine **20**, 183 (2005).
- [14] G. Krishnaswamy and G. Baranoski, *A biophysically based spectral model of light interaction with human skin*, Computer graphics forum **23**, 331 (2004).
- [15] A. Barel, M. Paye, and H. Maibach, *Handbook of Cosmetics, Science and Technology* (Informa Healthcare USA, 2009).

- [16] I. Saknite, *Optical non-invasive estimation and mapping of skin bilirubin, hemoglobin and water*, Ph.D. thesis, University of Latvia, Riga (2015).
- [17] R. R. Anderson, W. Farinelli, H. Laubach, D. Manstein, A. N. Yaroslavsky, J. Gubeli, K. Jordan, G. R. Neil, M. Shinn, W. Chandler, *et al.*, *Selective photothermolysis of lipid-rich tissue: a free electron laser study*, *Lasers in Surgery and Medicine* **38**, 913 (2006).
- [18] G. B. Altshuler, R. R. Anderson, and D. Manstein, *Method and apparatus for the selective targeting of lipid-rich tissues*, (2003), U.S. Patent 09,277,307.
- [19] S. L. Jacques, *Optical properties of biological tissues: a review*, *Physics in Medicine and Biology* **58**, 37 (2013).
- [20] C. P. Fleming, J. Eckert, and E. F. Halpern, *Depth resolved detection of lipid using spectroscopic optical coherence tomography*, *Biomedical optics express* **4**, 1269 (2013).
- [21] A. M. Smith, M. C. Mancini, and S. Nie, *Bioimaging: second window for in vivo imaging*, *Nature nanotechnology* **4**, 710 (2009).
- [22] K. Maruo and Y. Yamada, *Near-infrared noninvasive blood glucose prediction without using multivariate analyses: introduction of imaginary spectra due to scattering change in the skin*, *Journal of biomedical optics* **20**, 047003 (2015).
- [23] S. L. Jacques and D. J. McAuliffe, *The melanosome: threshold temperature for explosive vaporization and internal absorption coefficient during pulsed laser irradiation*, *Photochemistry and Photobiology* **53**, 769 (1991).
- [24] S. Luebberding, N. Krueger, and M. Kerscher, *Skin physiology in men and women: in vivo evaluation of 300 people including tawl, sc hydration, sebum content and skin surface ph*, *International Journal of Cosmetic Science* **35**, 477 (2013).
- [25] J. Fluhr, S. Lazzarini, F. Distanto, M. Gloor, and E. Berardesca, *Effects of prolonged occlusion on stratum corneum barrier function and water holding capacity*, *Skin pharmacology and physiology* **12**, 193 (1999).
- [26] D. P. Lookingbill and W. J. Cunliffe, *Method for quantification of oils and sebum levels on skin using the sebumeter*, *International journal of cosmetic science* **38**, 210 (2016).
- [27] D. P. Lookingbill and W. J. Cunliffe, *A direct gravimetric technique for measuring sebum excretion rate*, *British Journal of Dermatology* **114**, 75 (1986).
- [28] A. R. Msabbri, M. Mohamad, M. Z. MatJafri, and A. F. Omar, *Development of optical near-infrared spectroscopy instruments for human skin sebum measurement*, in *Biophotonics: Photonic Solutions for Better Health Care IV*, Vol. 9129 (International Society for Optics and Photonics, 2014) p. 91293M.

- [29] M. Janssens, J. van Smeden, and G. J. Puppels, *Lipid to protein ratio plays an important role in the skin barrier function in patients with atopic eczema*, *British Journal of Dermatology* **170**, 1248 (2014).
- [30] S. Naito, Y. K. Min, and K. Sugata, *In vivo measurement of human dermis by 1064-nm-excited fiber raman spectroscopy*, *Skin Research and Technology* **14**, 18 (2008).
- [31] E. Yagi, K. Sakamoto, and K. Nakagawa, *Depth dependence of stratum corneum lipid ordering: A slow-tumbling simulation for electron paramagnetic resonance*, *Journal of Investigative Dermatology* **127**, 895 (2007).
- [32] T. McIntosh, M. Stewart, and D. Downing, *X-ray diffraction analysis of isolated skin lipids: reconstitution of intercellular lipid domains*, *Biochemistry* **35**, 3649 (1996).
- [33] A. Ezerskaia, S. F. Pereira, H. P. Urbach, R. Verhagen, and B. Varghese, *Quantitative and simultaneous non-invasive measurement of skin hydration and sebum levels*, *Biomedical Optics Express* **7**, 2311 (2016).
- [34] U. Heinrich, U. Koop, and M. C. Leneveu-Duchemin, *Multicentre comparison of skin hydration in terms of physical, physiological and product-dependent parameters by the capacitive method (corneometer cm 825)*, *International Journal of Cosmetic Science* **25**, 45 (2003).
- [35] W. Mason and J. Gallin, *Fluorescent and Luminescent Probes for Biological Activity* (Academic Press, Cambridge, 1999).
- [36] C. Ash, M. Dubec, K. Donne, and T. Bashford, *Effect of wavelength and beam width on penetration in light-tissue interaction using computational methods*, *Lasers in Medical Science* **32**, 1908 (2017).
- [37] P. Caspers, G. Lucassen, H. Bruining, and G. Puppels, *Automated depth-scanning confocal raman microspectrometer for rapid in vivo determination of water concentration profiles in human skin*, *Journal of Raman Spectroscopy* **31**, 813 (2000).
- [38] N. Dayan, *Skin Aging Handbook* (William Andrew, Norwiche, USA, 2008).
- [39] J. Logger, C. Münchhoff, J. Olydam, M. Peppelman, and P. van Erp, *Anatomical site variation of water content in human skin measured by the epsilon: A pilot study*, *Skin Research and Technology* **25**, 333 (2019).
- [40] E. Attas, M. Sowa, T. Posthumus, B. Schattka, H. Mantsch, and S. Zhang, *Near-ir spectroscopic imaging for skin hydration: The long and the short of it*, *Biopolymers* **67**, 96 (2002).
- [41] P. Thune, T. Nilsen, I. Hanstad, H. Gustavsen, and H. D. Lövig, *The water barrier function of the skin in relation to the water content of stratum corneum, ph and skin lipids. the effect of alkaline soap and syndet on dry skin in elderly, non-atopic patients*, *Acta Dermato-Venereologica* **68**, 277 (1988).

- [42] G. Yosipovitch, G. Xiong, E. Haus, L. Sackett-Lundeen, I. Ashkenazi, and H. Maibach, *Time-dependent variations of the skin barrier function in humans: Transepidermal water loss, stratum corneum hydration, skin surface pH, and skin temperature*, *Journal of Investigative Dermatology* **110**, 20 (1998).
- [43] J. Fluhr, M. Gloor, S. Lazzerini, P. Kleesz, R. Grieshaber, and E. Berardesca, *Comparative study of five instruments measuring stratum corneum hydration (corneometer cm 820 and cm 825, skicon 200, nova dpm 9003, dermalab). part i. in vitro*, *Skin Research and Technology* **5**, 161 (1999).
- [44] P. Clarys, A. Barel, and B. Gabard, *Non-invasive electrical measurements for the evaluation of the hydration state of the skin: comparison between three conventional instruments - the comeometer®, the skicon® and the nova dpm®*, *Skin research and Technology* **5**, 14 (1999).
- [45] M. Egawa and H. Tagami, *Comparison of the depth profiles of water and water-binding substances in the stratum corneum determined in vivo by raman spectroscopy between the cheek and volar forearm skin: effects of age, seasonal changes and artificial forced hydration*, *British Journal of Dermatology* **158**, 251 (2008).
- [46] M. Egawa, T. Hirao, and M. Takahashi, *In vivo estimation of stratum corneum thickness from water concentration profiles obtained with raman spectroscopy*, *Acta Dermato-Venereologica* **87**, 4 (2007).
- [47] N. Nakagawa, M. Matsumoto, and M. Sakai, *In vivo measurement of the water content in the dermis by confocal raman spectroscopy*, *Skin Research and Technology* **16**, 137 (2010).
- [48] P. Caspers, H. Bruining, G. Puppels, G. Lucassen, and E. Carter, *In vivo confocal raman microspectroscopy of the skin: Noninvasive determination of molecular concentration profiles*, *Journal of Investigative Dermatology* **116**, 434 (2001).
- [49] F. Jean, G. Bourg-Heckly, and B. Viellerobe, *Fibered confocal spectroscopy and multicolor imaging system for in vivo fluorescence analysis*, *Optics Express* **15**, 4008 (2007).
- [50] A. Ezerskaia, N. Uzunbajakava, G. Puppels, J. de Sterke, P. Caspers, P. Urbach, and B. Varghese, *Potential of short-wave infrared spectroscopy for quantitative depth profiling of stratum corneum lipids and water in dermatology*, *Biomedical Optics Express* **9**, 2436 (2018).
- [51] A. Ezerskaia, A. Ras, P. Bloemen, S. F. Pereira, H. P. Urbach, and B. Varghese, *High sensitivity optical measurement of skin gloss*, *Biomed Opt Express* **8**, 3981 (2017).
- [52] A. Matsubara, *Differences in the surface and subsurface reflection characteristics of facial skin by age group*, *Skin Research and Technology* **18**, 29 (2012).
- [53] P. Elsner, H. Maibach, and H. Merk, *Cosmetics* (Springer-Verlag Berlin Heidelberg, 1999).



- [54] P. Humbert, F. Fanian, H. Maibach, and P. Agache, *Agache's Measuring the Skin* (Springer International Publishing Switzerland, 2017).
- [55] D. Lee, C. Huh, and J. Ra, *Clinical evidence of effects of lactobacillus plantarum hy7714 on skin aging: A randomized, double blind, placebo-controlled study*, *Journal of Microbiology and Biotechnology* **25**, 2160 (2015).
- [56] G. Nam, J. Baek, J. Koh, and J. Hwang, *The seasonal variation in skin hydration, sebum, scaliness, brightness and elasticity in korean females*, *Skin Research and Technology* **21**, 1 (2015).

# 2

## QUANTITATIVE AND SIMULTANEOUS NON-INVASIVE MEASUREMENT OF SKIN HYDRATION AND SEBUM LEVELS\*

*We report a method on quantitative and simultaneous non-contact in-vivo hydration and sebum measurements of the skin using an infrared optical spectroscopic set-up. The method utilizes differential detection with three wavelengths 1720, 1750, and 1770 nm, corresponding to the lipid vibrational bands that lay "in between" the prominent water absorption bands. We have used an emulsifier containing hydro- and lipophilic components to mix water and sebum in various volume fractions which was applied to the skin to mimic different oily-dry skin conditions. We also measured the skin sebum and hydration values on the forehead under natural conditions and its variations to external stimuli. Good agreement was found between our experimental results and reference values measured using conventional biophysical methods such as Corneometer and Sebumeter.*

---

\*Parts of this chapter have been published in Biomedical Optics Express 7, (6), 2311-2320 (2016) [1].

## 2.1. INTRODUCTION

Skin hydration (moisture) and sebum (skin surface lipids) are considered to be important factors in skin health; a right balance between these components is an indication of healthy skin and plays a central role in protecting and preserving skin integrity [2]. Optimal balance between hydration and sebum levels provides the skin with a radiant, smooth texture and a natural pigmentation appearance, which is important from a cosmetic perspective. Hydration and sebum retaining ability of the skin is primarily related to the stratum corneum (SC). The SC plays the role of the barrier to water loss and is composed of the corneocytes and an intercellular lipid bilayer matrix. The water retaining property of the SC is dependent on these two major components. The presence of natural hygroscopic agents collectively referred to as natural moisturizing factor (NMF) and the SC intercellular lipids arrange orderly to form a barrier to prevent transepidermal water loss. Epithelium remains flexible when it contains 10-20% water, but becomes brittle, when it drops below 10% [3]. Stratum corneum receive hydration underneath skin layers and to a lesser extent from the atmosphere [4]. Skin conditions such atopic dermatitis shows drop in skin hydration level reflecting in a drop of water holding capacity of the skin, increased transepidermal water loss (TEWL) and defect in barrier function [5–7]. The same symptoms are seen in individuals suffering from psoriasis, eczema and ichthyosis vulgaris [8, 9]. This similarity in symptoms leads to complications with diagnostics, which often requires a biopsy, an invasive approach [10]. Nevertheless, these mentioned disorders show peculiar skin conditions with respect to the balance between hydration and oiliness. Eczema leads to minor water loss (few percent) combined with noticeable oiliness drop (~25%) [11, 12], whereas psoriasis shows dramatic decrease of hydration (~70%) and oiliness (~40-70%) levels [13]. Ichthyosis vulgaris shows decrease of hydration level (~63%) while the level of superficial skin lipids does not vary significantly ( $\pm 15\%$ ) [14, 15].

Studies show that superficial lipids play an important role in the barrier function, creating a filter for interaction with the external environment. Skin health is associated with the stability of the functioning of the skin barrier, which depends on the continuity of the skin's superficial lipids structure [16, 17]. Lipid phase behavior in the stratum corneum is considered to be crucial for the skin barrier function [18]. Skin superficial lipids have been found to serve as water modulator in the stratum corneum [19]. Thus, the water-sebum system determines the condition of the skin and can be used as an indicator of skin health.

Sebum is a mixture of fatty acids, triglycerides, proteins, and other molecules produced by the sebaceous glands in the dermis. Sebum keeps the skin smooth and flexible by sealing and preserving moisture in the corneal layer and preventing evaporation and bacterial infections. The sebum excretion rate (SER) reflects the amount of sebum production and is closely related to the physiological activities of the sebaceous glands. This is important information in the pathogenesis of sebaceous glands disorders and pimples and acne. Excessive sebum production can cause clogged pores possibly resulting in blemishes. Sufficient amount of skin hydration and sebum makes the skin appear smooth, soft and supple whereas the lack of moisture can cause the skin to look dull and cracked, appearing older [20]. The reduction in the efficiency of the barrier and moisture-maintaining functions of the skin results in easily dried, roughened skin which

can be potentially more vulnerable to risk of infection [16].

The most well-established commercially available moisture detectors measure electrical properties such as capacitance and alternating current conductivity on the skin surface. Transepidermal water loss (TEWL) expressed in grams per square meter and per hour is used for studying the water barrier function of the human skin. However the method is very sensitive to environmental changes and requires several minutes to retrieve stable readings. The most commonly used skin hydration measuring devices are Skicon<sup>®</sup> 200, Corneometer<sup>®</sup> CM820, Nova DPM<sup>®</sup> 9003. These devices use rigid probes which must be in contact with the skin. Furthermore, the measurements are influenced by the amount of electrolytes, contact area, applied pressure and are sensitive to the external temperature and humidity. Furthermore these methods are not suitable for measuring changes in the hydration levels over time and to visualize the spatial distribution and heterogeneity of the skin moisturizing-ability of the whole face [21]. Near infrared multispectral imaging is an optical method that measures skin hydration based on the prominent water absorption peaks in the absorption spectrum. For methods which use shorter wavelengths, the absorption of water is very low while the scattering volume is high, resulting in a higher light scattering and influence of other skin chromophores on the measured hydration levels [22]. The measured values of hydration are influenced by the presence of other chromophores in methods using a single wavelength. In order to correct for the influence and artefacts arising from other chromophores, an analytic method based on the difference in absorbance of two NIR wavelength bands (1060 nm and 1450 nm) have been reported [23]. These methods use widely spaced wavelengths where the variation in wavelength dependent scattering effects also influences the measurement results. In all optical methods reported above, the results are influenced by various factors such as wavelength dependent scattering effects, the presence of other chromophores and none of them are able to measure sebum and hydration simultaneously.

Presently available sebum measuring devices are based on grease-spot photometry and gravimetric analysis that are both tedious and time-consuming [24–26]. The most well-established commercially available devices measure optical properties such as skin gloss, and sebutape transparency. The gravimetric method provide more accurate results along with increased complexity of obtaining data [26]. The most commonly used skin surface lipids measuring devices are Sebumeter and Glossometer. These devices need to be in contact with the skin and use non-disposable rigid probes. Furthermore, measurements can be influenced by contact area, applied pressure and time of applying. Furthermore, they are sensitive to skin pollution and can be sensitive to atmosphere humidity changes. Moreover, they are not suitable for measuring changes in the sebum levels over time and for visualizing the spatial distribution and heterogeneity of the skin oiliness of the whole face.

In short, in spite of many technological developments throughout the years, until now no non-contact devices and methods have been reported for the quantitative and simultaneous measurement of skin superficial lipids and water. Development of a non-contact method for measuring skin hydration and sebum simultaneously will enable to assess the balance between these factors related to skin health and to select the appropriate skin care treatment and products and will make it possible to monitor the progress

during treatment.

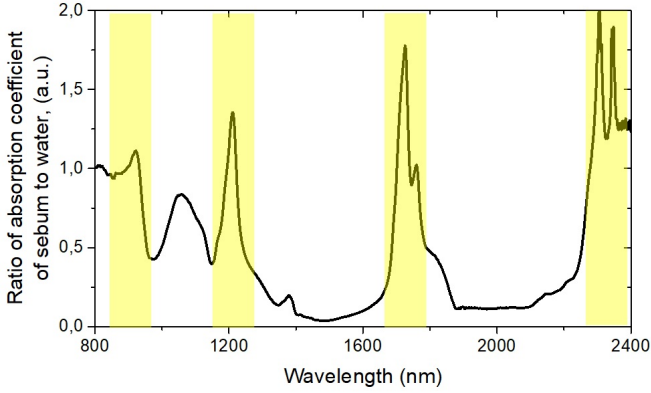
In this chapter, we report on quantitative and simultaneous non-contact in-vivo sebum and hydration measurements using a short wave infrared optical spectroscopic set-up using differential detection between three wavelengths 1720, 1750, 1770 nm. Initially, we measured the absorption properties of artificial sebum and water in the spectral range from 400-2000 nm and identified the spectral bands around 1720 nm corresponding to the lipid vibrational bands that lay “in between” the prominent water absorption bands. We built an experimental set-up that was employed to shine light at these three wavelengths to the skin and detect the light backscattered from the skin using a Ge photodiode. We have applied  $20 \mu\text{g}/\text{cm}^2$  of sebum-water mixtures in different volume fractions on the skin to mimic different oily-dry skin conditions. The estimated sebum and hydration levels were compared with conventional devices Corneometer CM825 (Courage & Khazaka electronic) and Sebumeter SM 815 (Courage & Khazaka electronic). Good agreement between experimental results and reference measurements were found.

## 2.2. MATERIALS AND METHODS

We measured absorption spectra of skin surface lipids (artificial sebum) and water using an integrating sphere spectrophotometer (PerkinElmer Lambda 900, 150 mm) and calculated the ratio of absorption coefficients (Fig. 2.1) which shows a good agreement with the known spectrum of human adipose tissue [27, 28]. Artificial sebum showed sufficiently high contrast and absorption peaks near 1210, 1728, 1760, 2306 and 2346 nm. This is in agreement with previous studies that report values of optimal wavelengths that potentially are able to target lipid rich tissue such as sebaceous glands and subcutaneous fat [27, 28]. The spectral band for simultaneous sensing of hydration and sebum levels is optimally chosen to have high absorption coefficients of water and sebum and at the same time a large ratio of these absorption coefficients to obtain high contrast between the two chromophores. The spectral window around 1700 nm have high absolute values of the absorption coefficient and a high ratio of the absorption coefficient of sebum to the one of water and, simultaneously, a minimal influence of other skin chromophores such as melanin and blood.

The experimental setup (Fig. 2.2) used for the skin hydration and oiliness level measurement comprises three quasi continuous laser sources, beam shaping optics and mirrors to guide the laser beam via the beam path. The laser sources (LD 1, LD 2, LD 3) were short wave infrared semiconductor lasers diodes emitting a wavelength of  $1720 \pm 4$  nm,  $1750 \pm 5$  nm,  $1770 \pm 20$  nm emitting approximately 40 mW at each wavelength. The lasers are spatially combined along the same optical path using flipping mirrors (FM1, FM2). The beams are focused one by one through a central aperture in the mirror (M5) before it illuminates an area of approximately  $12.6 \text{ mm}^2$  on the skin surface with a power of approximately 10 mW for each wavelength. This corresponds to  $0.08 \text{ W}/\text{cm}^2$ , which is below the acceptable safety limit of  $0.1 \text{ W}/\text{cm}^2$  in this spectral range. Light backscattered from the skin is collimated and reflected by the mirror (M5) and focused at the detector (PD) using a focusing lens (L10). The polarizers (P1<sup>s</sup> and P2<sup>p</sup>) are set in crossed polarization configuration.

To mimic different natural dry and oily skin conditions, we applied mixtures of water



**Figure 2.1:** Ratio of absorption coefficient of sebum to water measured in the shown spectral range between 800 to 2400 nm. Yellow bands represent the optimal spectral bands for simultaneous hydration and sebum sensing defined by high absorption coefficients of water and sebum and a large ratio of the absorption coefficients to obtain high contrast.

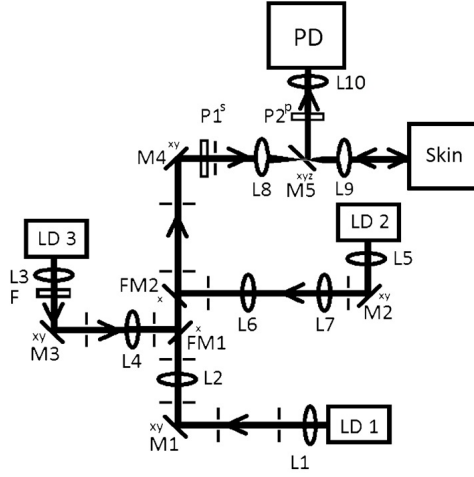
and sebum in various volume fractions ranging from 0-100% on the skin of forearms of two healthy volunteers (skin type I-II). Water and sebum (wfk Testgewebe GmbH) were mixed using an emulsifier (Triton-X 100, 5%). The study was approved by the ethical committee and all volunteers gave written informed consent. Measurements were repeated five times for each volume fraction. Corneometer and Sebumeter was used for hydration and sebum reference measurements respectively.

We calculated the volume fraction of sebum and water for all applied mixtures from the ratio of backscattered light to the incident light intensity for each wavelength. The amount of water ( $c_w$ ) and lipids ( $c_s$ ) were calculated from this ratio using an algorithm based on Beer-Lambert's law for light propagation in scattering media. The wavelengths 1720 nm and 1750 nm are used for estimating the sebum content and 1750 nm and 1770 nm for the water content.

$$I_1 = I_{0_1} \cdot \exp\left(-\left(\mu'_{s_1} + \mu_{a_{s_1}} \cdot c_s \cdot \mu_{a_{w_1}} \cdot c_w\right) \cdot z\right) \quad (2.1)$$

$$I_2 = I_{0_2} \cdot \exp\left(-\left(\mu'_{s_2} + \mu_{a_{s_2}} \cdot c_s \cdot \mu_{a_{w_2}} \cdot c_w\right) \cdot z\right) \quad (2.2)$$

where  $c_s$  – volume fraction of sebum,  $c_w$  – volume fraction of water,  $z$  – depth of penetration,  $\mu_{a_{s_1}}$  – absorption coefficient for sebum at  $\lambda_1$ ,  $\mu_{a_{s_2}}$  – absorption coefficient for sebum at  $\lambda_2$ ,  $\mu_{a_{w_1}}$  – absorption coefficient for water at  $\lambda_1$ ,  $\mu_{a_{w_2}}$  – absorption coefficient for water at  $\lambda_2$ ,  $\mu'_{s_1}$  – scattering coefficient at  $\lambda_1$ ,  $\mu'_{s_2}$  – scattering coefficient at  $\lambda_2$ ,  $I_{0_x}$  – intensity of incident radiation,  $I_1$  – intensity detected at  $\lambda_1$ ,  $I_2$  – intensity detected at  $\lambda_2$ . From these equations, the volume fraction of sebum and water are estimated as follows:



**Figure 2.2:** Schematic of the experimental set-up: LD1 - Laser Diode ( $1720 \pm 4$  nm, Roithner Laser), LD2 - Laser Diode ( $1750 \pm 5$  nm, Roithner Laser), LD3 - Laser Diode ( $1770 \pm 20$  nm, Roithner Laser), F - Narrowband filter ( $1770 \pm 5$  nm, Spectrogon), M1, M2, M3, M4 - mirrors, M5 - Mirror with a central aperture, FM1, FM2 - Flipping mirrors, L1, L3, L5 - Aspheric lenses, L2 ( $f = 300$  mm), L4 ( $f = 300$  mm), L6 ( $f = 75$  mm), L7 ( $f = 150$  mm), L8 ( $f = 35$  mm) - Plano convex lenses, L9 ( $f = 35$  mm) - Biconvex lens, L10 ( $f = 25.4$  mm, LA1951-C), P1<sup>s</sup>, P2<sup>P</sup>, PD - photodiode (DET30B/M).

$$c_s = \frac{\ln\left(\frac{I_{o2}}{I_2}\right) \cdot \frac{1}{z \cdot \mu_{aw2}} - \frac{\mu'_{s2}}{\mu_{aw2}} - n\left(\frac{I_{o1}}{I_1}\right) \cdot \frac{1}{z \cdot \mu_{aw1}} + \frac{\mu'_{s1}}{\mu_{aw1}}}{\frac{\mu_{as2}}{\mu_{aw2}} - \frac{\mu_{as1}}{\mu_{aw1}}} \quad (2.3)$$

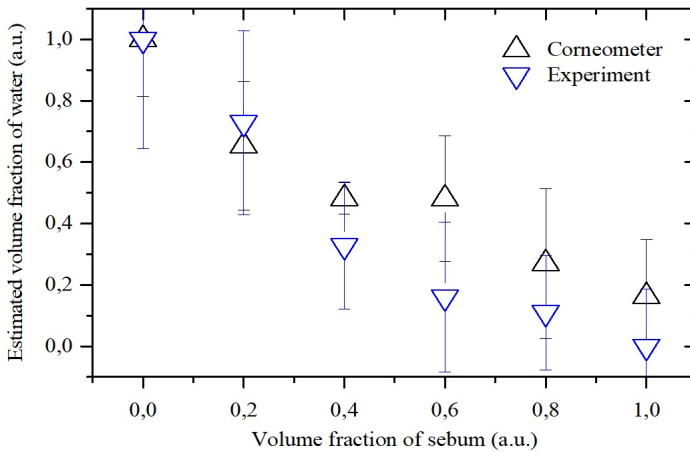
$$c_w = \frac{\ln\left(\frac{I_{o1}}{I_1}\right) \cdot \frac{\mu'_{s2}}{z} - z \cdot \mu'_{s1} \cdot \left(\mu_{as2} - 2 \cdot \mu_{aw2} \cdot \mu_{as1} \cdot \mu_{aw1}\right) - \ln\left(\frac{I_{o2}}{I_2}\right) \cdot \frac{\mu_{as1}}{z} + \mu_{as1} \cdot \mu'_{s2}}{\mu_{as2} \cdot \mu_{aw1} - \mu_{as1} \cdot \mu_{aw2}} \quad (2.4)$$

To measure the natural skin condition and its response to different stimuli, experiments were carried out on the forehead. In order to simulate different levels of oiliness and hydration of the conditions standard techniques were used [29, 30]. High hydration level of the skin was reached by applying a wet wool fabric for 30 minutes. 70% isopropanol was used for decreasing hydration and oiliness level of the skin. Natural levels of sebum on the T-zone for oily skin corresponds to  $20 \mu\text{g}/\text{cm}^2$  [30]. The condition dry skin with excessive oiliness was replicated by applying artificial sebum on the treated area. Measurements were performed using our experimental prototype device and with Corneometer and Sebumeter for reference measurements.

### 2.3. RESULTS

The volume fraction of water and sebum measured for different sebum-water mixtures applied onto the skin are shown in Figures (2.3) and (2.4) respectively. The vertical

axis corresponds to the estimated amount of water (Fig. 2.3) and sebum (Fig. 2.4), while the horizontal axis corresponds to volume fraction of sebum in the applied sebum-water mixture. Hydration measured with Corneometer and sebum measured with Sebometer are also shown in the figure for comparison. The error bars represent the standard deviation of three measurements. The results show direct dependency of estimated sebum fraction on the concentration of sebum in the applied emulsion. The same behavior is observed for water concentration variations in the emulsions. The measurements show good correlation between the experimental setup and standard devices. The correlation coefficients of our results for water and sebum with Corneometer and Sebometer measurements are  $R \sim 0.95$ ,  $p = 0.0028$  and  $R \sim 0.99$ ,  $p = 0$  respectively.



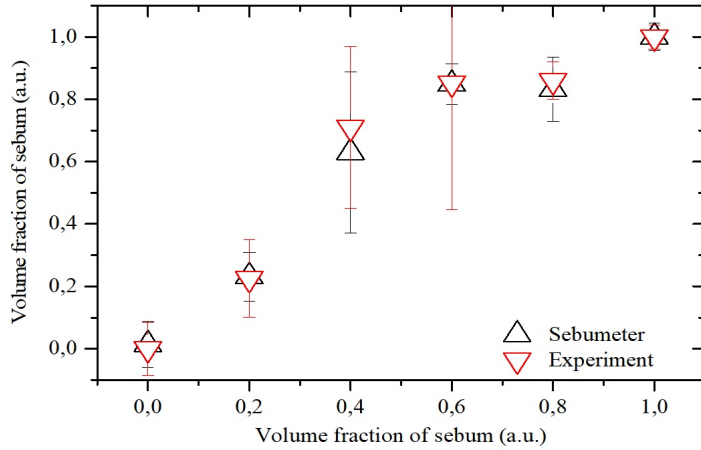
**Figure 2.3:** Volume fraction of water measured in-vivo using our experimental set-up and Corneometer for different water-sebum mixture samples.

Figure (2.5) depicts five types of skin conditions depending on the hydration and sebum levels on the skin. The horizontal axis shows hydration and the vertical axis shows the oiliness of the investigated skin area; solid bullets are reference measurements using standard devices, and open symbols represent our experimental results. The measurement of the T-zone on the forehead measured under natural conditions are shown in green circles.

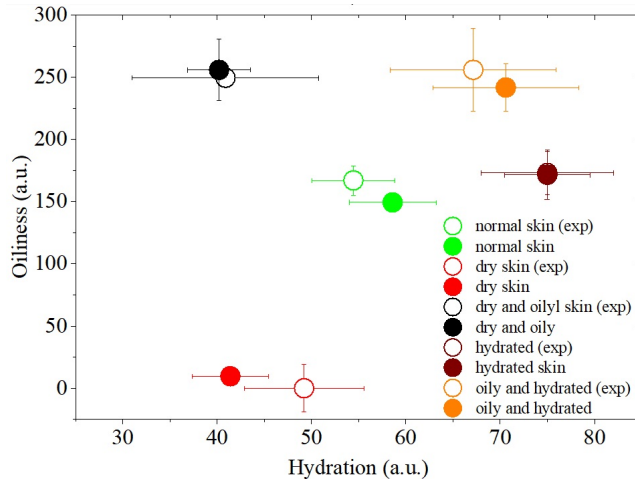
## 2.4. DISCUSSION

The experimental results of our non-invasive infrared spectroscopic method to simultaneously determine skin surface lipids and hydration volume fractions show good agreement with the commercial instruments Corneometer and Sebometer. In our study, we have used wavelengths near 1720 nm because the absorption coefficient of sebum and water and the corresponding ratio of absorption coefficients are high in this spectral range. Also, the influence of other skin chromophores such as melanin and blood is expected to be lower in this spectral range compared to other shorter wavelengths. The lipid absorption bands around 1210 nm and 2200 nm are also interesting based on the higher values of absorption contrast between sebum and water that varies significantly





**Figure 2.4:** Volume fraction of sebum measured in-vivo using our experimental set-up and Sebumeter for different water-sebum mixture samples.



**Figure 2.5:** Mapping of various skin conditions on the forehead and its variations to different stimuli and comparison with Corneometer and Sebumeter.

in narrow spectral band of 50 nm. Even though the other absorbers such as collagen [31], blood [32] and proteins [33] can also influence our experimental results in this spectral region around 1720 nm the absolute values of absorption coefficient and the amount of these chromophores present in the measurement volume of our set-up is relatively lower compared to water and sebum [12]. The maximum water content in the skin changes from 30% in stratum corneum to 70% in epidermis. The spectral band around 1700 nm is expected to be less sensitive for other chromophores when the sampling depth [34] of the optical set-up is chosen to be optimized for measuring skin barrier function, which in turn depends on the properties of stratum corneum. Nevertheless, the influence of

protein absorption has to be considered in this spectral band around 1720 nm for the application focused on determination of stratum corneum hydration and oiliness. The ratio of sebum to proteins can be in the range of 1/3 to 2/3 for clinically healthy individual [35] and thus absorption losses can be primarily related to three chromophores: water, sebum and protein. Protein content is nearly constant for healthy individual, so it can be accounted as a baseline correction factor in the calculations.

The strong absorption of lipids at the wavelengths near 1720 nm is caused by vibrational overtone modes, in particular from the C-H stretching [36–38]. Although artificial sebum has a chemical composition that differs from natural sebum, the absorption spectra of artificial and natural sebum shows absorption maxima at 1210 nm, 1728 nm, 2306 nm and 2346 nm [27, 28]. In our calculations, we have used combination of the wavelengths 1720 nm and 1750 nm for estimating the sebum content and 1750 nm and 1770 nm for the water content. The same results can also be obtained by using the combination of  $\lambda_s = 1720$  nm,  $\lambda_0 = 1705$  nm,  $\lambda_w = 1694$  nm. In general, for this application any set of sources with wavelengths corresponding to maximal ( $\lambda_s$ ), minimal ( $\lambda_w$ ) and equal ( $\lambda_0$ ) ratio of absorption coefficient of sebum to water could be used. The accessibility of certain light sources was the final criterion in choosing the first set of wavelengths.

Even though our measurements show agreement with the reference measurements obtained with Corneometer and Sebumeter, direct comparison of our results with these commercial devices is difficult as the techniques sample different depths inside the skin. To investigate the measuring depth of our experimental set-up, experiments were performed on layers of sebum of various thicknesses applied to the skin. The experiments were performed by applying water-sebum emulsion (40% vol. of sebum & 60% vol. of water) in increasing layer of thickness from 0 to 1 mm in steps of 100  $\mu\text{m}$  on a highly absorbing layer to avoid the possible long path length photons that may penetrate beyond the first layer. These experiments suggest that the imaging depth of our experimental set-up is approximately 350  $\mu\text{m}$  and that the light backscattered from the epidermis also contributes to the measured values. Nevertheless the estimation of imaging depth can be influenced by the factors such as varying scattering properties of mixture, thickness of applied emulsion. The sampling volume can be optimized for various dermatological applications by changing the illumination-detection geometry of our experimental set-up such as oblique incidence, source-detector separation [39].

The large error bars observed in our measurements are due to the non-homogeneity of the water-sebum mixture and variation in the thickness of the applied layer. Most detected light in this experimental configuration is coming from the layer applied on the skin and therefore can be highly dependent on the non-homogeneity of the mixture and layer thickness. Our approach to mix sebum and water using an emulsifier does not guarantee perfect uniformity and thickness of the applied layer. In addition to this, when sebum and water are mixed in various volume fractions, we observe significant differences in the scattering properties of the sample. This becomes prominent when the volume fractions of the individual components are comparable. One of the potential advantages of our method is that it is insensitive to the presence and variation of other skin chromophores such as blood and melanin. Hence our optical method can be applied independent of skin type. Moreover, the probe does not need to be in contact with the skin so that the repeated measurements can be performed on the same location

without changing the skin conditions.

Further in-vivo studies were performed with this prototype device in a panel test to measure inter-and intra-individual variations in skin sebum and hydration levels and its variations to external stimuli and to compare these results with standard devices. These results will be reported separately in the near future. Quantitative and simultaneous determination of these two biophysical parameters as demonstrated in this study will enable the clinicians to classify the skin types into Normal skin (N), Dry skin (D), Oily Skin (O), Oily-Hydrated skin (OH) and oily-dry skin (OD) and can provide personalized skin treatment solutions.

## 2.5. CONCLUSION

This study presents a novel non-invasive short wave infrared spectroscopic technique for simultaneous measurement of oiliness and hydration levels of the skin. We have built an experimental set-up operating in the spectral region around 1720 nm, utilizing the lipid vibrational bands that lay “in between” the prominent water absorption bands. Sebum and water was mixed in various volume fractions using an emulsifier and was applied onto the skin to mimic different dry-oily skin conditions. The amount of sebum and water estimated from the backscattered light measurements from the skin using this short wave infrared spectroscopic set-up showed good agreement with the values measured with both the commercially available Sebumeter and Corneometer. Furthermore the method is, to a large extent, independent of the presence of other chromophores such as blood and melanin. The natural sebum and hydration levels measured on the T-zone of the forehead and its variations due to external stimuli as measured with our set-up are in good agreement with the reference measurements obtained using the above mentioned commercial devices. To summarize, the preliminary results demonstrate the feasibility of this novel noninvasive optical method for simultaneously measuring the hydration and sebum retaining ability of the skin.

## REFERENCES

- [1] A. Ezerskaia, S. F. Pereira, H. P. Urbach, B. Verhagen, and B. Varghese, *Quantitative and simultaneous non-invasive measurement of skin hydration and sebum levels*, *Biomedical Optics Express* **7**, 2311 (2016).
- [2] N. Dayan, *Skin Aging Handbook* (William Andrew Inc, New York, 2008).
- [3] I. H. Blank, *Further observations on factors which influence the water content of the stratum corneum*, *Journal of Investigative Dermatology* **21**, 259 (1985).
- [4] I. H. Blank, *Factors which influence the water content of the stratum corneum*, *Journal of Investigative Dermatology* **18**, 433 (1952).
- [5] Y. L. Werner, *The water content of the stratum corneum in patients with atopic dermatitis*, *AActa Dermato-Venereologica* **66**, 281 (1986).
- [6] G. N. Stamatias and E. Boireau-Adamezyk, *Development of a non-invasive optical method for assessment of skin barrier to external penetration*, in *Biomedical Optics and 3-D Imagin* (Optical Society of America, 2012) pp. JM3A–42.
- [7] Y. L. Werner and M. Lindberg, *Transepidermal water loss in dry and clinically normal skin in patients with atopic dermatitis*, *Acta Dermato-Venereologica* **65**, 102 (1985).
- [8] S. H. Takada, S. Naito, J. Sonda, and Y. Miyauchi, *Measurement of natural moisturizing factor content in stratum corneum of human skin by attenuated total reflection infrared spectroscopy*, *Applied Spectroscopy* **66**, 26 (2012).
- [9] J. Ring, T. Ruzicka, and B. Przybilla, *Handbook of atopic eczema* (Springer-Verlag Berlin, 2006).
- [10] A. Menter, A. Gottlieb, S. Feldman, S. van Voorhees, C. L. Leonardi, K. B. Gordon, M. Lebwohl, J. Y. M. Koo, C. A. Elmets, N. J. Korman, K. R. Beutner, and R. Bhushan, *Guidelines of care for the management of psoriasis and psoriatic and arthritis. section 1. overview of psoriasis and guidelines of care for treatment of psoriasis with biologic*, *Journal of the American Academy of Dermatology* **58**, 826 (2008).
- [11] J. Ring, B. Eberlein-König, T. Schäfer, J. Huss-Marp, U. Darsow, M. Möhrenschrager, O. Herbert, D. Abeck, U. Krämer, and H. Behrendt, *Skin surface pH, stratum corneum hydration, trans-epidermal water loss and skin roughness related to atopic eczema and skin dryness in a population of primary school children: clinical report*, *Acta Dermatology-Venerology* **80**, 188 (2000).
- [12] M. Janssens, J. van Smeden, G. Puppels, A. P. M. Lavrijsen, P. J. Caspers, and J. A. Bouwstra, *Lipid to protein ratio plays an important role in skin barrier function in patients with atopic eczema*, *British Journal of Dermatology* **170**, 1248 (2014).
- [13] J. Kim, J. Jeon, and H. Song, *Evaluation of the degree of skin dryness and the effect of moisturizing therapy in scalp psoriasis*, *Annual Global Pharma Summit, Philadelphia, USA* **66**, 338 (2015).

- [14] Y. Tomita, M. Akiyama, and H. Shimizu, *Stratum corneum hydration and flexibility are useful parameters to indicate clinical severity of congenital ichthyosis*, *Experimental Dermatology* **14**, 619 (2005).
- [15] A. Lavrijsen, J. Bouwstra, G. Gooris, A. Bodde, and M. Ponec, *Reduced skin barrier function parallels abnormal stratum corneum lipid organization in patients with lamellar ichthyosis*, *Journal of Investigative dermatology* **105**, 619 (1995).
- [16] F. A. Addor and V. Aoki, *Skin barrier in atopic dermatitis*. *Annals of Dermatology* **85**, 184 (2010).
- [17] J. A. Bouwstra, P. L. Honeywell-Nguyen, G. S. Gooris, and M. Ponec, *Structure of the skin barrier and its modulation by vesicular formulations*, *Progress in Lipid Research* **42**, 1 (2003).
- [18] G. Zhang, A. Papillon, E. Ruvolo Jr., P. R. Bargo, and N. Kollias, *In vivo comparative documentation of skin hydration by confocal raman microscopy, skinsensor, skicon, and novameter*, in *Photonic Therapeutics and Diagnostics VI*, Vol. 7548 (International Society for Optics and Photonics, 2010) p. 75480M.
- [19] G. Imokawa, H. Kuno, and M. Kawai, *Stratum corneum lipids serve as a bound-water modulator*, *Journal of Investigative Dermatology* **96** (1991).
- [20] A. O. Barel, M. Paye, and H. I. Maibach, *Handbook of Cosmetic science and technology* (Informa Healthcare, New York, 2009).
- [21] M. Yasin, S. W. Harun, and H. Arof, *Selected Topics on Optical Fiber Technology* (In-Tech, Rijeka, 2012).
- [22] Y. Shirai, *Skin condition observation apparatus*, (2003), U.S. Patent 10,642,683.
- [23] H. Iwasaki, K. Miyazawa, and S. Nakauchi, *Visualization of the human face skin moisturizing-ability by spectroscopic imaging using two near-infrared bands*, in *Spectral Imaging: Eighth International Symposium on Multispectral Color Science*, Vol. 6062 (International Society for Optics and Photonics, 2006) p. 606203.
- [24] D. P. Lookingbill and W. J. Cunliffe, *A direct gravimetric technique for measuring sebum excretion rate*, *British Journal of Dermatology* **114**, 75 (1986).
- [25] S. Y. Pande and R. Miari, *Sebumeter*, *Indian Journal of Dermatology venerology and leprosy* **71**, 444 (2005).
- [26] *Courage + Khazaka electronic GmbH, Gcientific Devices, Skin Glossymeter GL 200*, <http://www.courage-khazaka.de/index.php/en/products/scientific/134-skin-glossymeter> (2015), (Accessed 30 November).
- [27] G. B. Altshuler, R. R. Anderson, and D. Manstein, *Method and apparatus for the selective targeting of lipid-rich tissues*, (2003), U.S. Patent 09,277, 307.

- [28] R. R. Anderson, W. Farinelli, L. Laubach, D. Manstein, A. N. Yaroslavsky, J. Gubeli, K. Jordan, G. R. Neil, M. Shinn, W. Chandler, G. P. Williams, S. V. Benson, D. R. Douglas, and H. F. Dylla, *Selective photothermolysis of lipid-rich tissue: a free electron laser study*, *Lasers in Surgery and Medicine* **38**, 913 (2006).
- [29] U. D. of Labor, *Occupational health guideline for isopropyl alcohol*, (1978).
- [30] M. Egawa, T. Hirao, and M. Takahashi, *In vivo estimation of stratum corneum thickness from water concentration profile obtained with raman spectroscopy*, *Acta Dermato-Venereologica* **87**, 4 (2007).
- [31] C. P. Fleming, J. Eckert, and E. F. Halpern, *Depth resolved detection of lipid using spectroscopic optical coherence tomography*, *Biomedical optics express* **4**, 1269 (2013).
- [32] A. M. Smith, M. C. Mancini, and S. Nie, *Bioimaging: second window for in vivo imaging*, *Nature nanotechnology* **4**, 710 (2009).
- [33] K. Maruo and Y. Yamada, *Near-infrared noninvasive blood glucose prediction without using multivariate analyses: introduction of imaginary spectra due to scattering change in the skin*, *Journal of biomedical optics* **20**, 047003 (2015).
- [34] S. K. Han, *Innovations and advances in wound healing* (Springer, Heidelberg, 2016).
- [35] N. Nakagawa, M. Matsumoto, and S. Sakai, *In vivo measurement of the water content in the dermis by confocal raman spectroscopy*, *Skin Research and Technology* **16**, 137 (2010).
- [36] D. P. Law and T. Tkachuk, *Near infrared diffuse reflectance spectra of wheat and components*, *Cereal Chemistry Journal* **54**, 256 (1976).
- [37] J. Workman and J. L. Weyer, *Practical Guide to Interpretive Near-Infrared Spectroscopy* (CRC Press, 2007).
- [38] H. I. Chung and H. J. Kim, *Near-infrared spectroscopy: Principles*, *Analytical science & Technology* **13**, 1 (2000).
- [39] V. V. Tuchin, *Handbook of Photonics for Biomedical Science* (Taylor & Francis, Boca Raton, 2010).



# 3

## POTENTIAL OF SHORT-WAVE INFRARED SPECTROSCOPY FOR QUANTITATIVE, DEPTH PROFILING OF STRATUM CORNEUM LIPIDS AND WATER IN DERMATOLOGY\*

*We demonstrate the feasibility of short wave infrared (SWIR) spectroscopy combined with tape stripping for depth profiling of lipids and water in the stratum corneum of human skin. The proposed spectroscopic technique relies on differential detection at three wavelengths of 1720, 1750, and 1770 nm, with varying ratio of the lipid-to-water absorption coefficient and an 'isosbestic point'. Comparison of the data acquired using SWIR spectroscopy with that obtained by a gold standard for non-invasive quantitative molecular-specific skin measurements, namely confocal Raman spectroscopy (CRS), revealed specificity of the proposed modality for water and lipid quantification. At the same time, we provide evidence showing aberrant sensitivity of Corneometer hydration read-outs to the presence of skin surface lipids, and a lack of sensitivity of the Sebumeter when attempting to measure the lipids of the cornified lipid envelope and intracellular lipid layers. We conclude that a spectroscopic SWIR-based spectroscopic method combined with tape stripping has the potential for depth profiling of the stratum corneum water and lipids, due to superior measurement sensitivity and specificity compared to the Corneometer and Sebumeter.*

---

\*Parts of this chapter have been published in Biomedical Optics Express 9, (5), 2436-2450 (2018) [1].



### 3.1. INTRODUCTION

#### 3.1.1. STRATUM CORNEUM STRUCTURE AND COMPOSITION

From an anatomic and physiological perspective, human skin represents a complete biologic universe. Not only does it house the skin appendages, such as sweat glands and pilosebaceous units, but also blood vessels, muscle tissue, nerves, components of immuno-competence and endocrine function [2]. Furthermore research over the past ten years has demonstrated the skin's remarkable stress sensing capacity [3].

While the function of human skin goes far beyond a guardian of water-holding capacity and mechanical integrity, evidently its most traditional mission remains to be forming a barrier to the hostile external environment [4], protecting against physical, chemical and microbial insults, as well as against water- and electrolyte loss [4, 5]. The barrier function of the skin is primarily fulfilled by the stratum corneum (SC), the outermost layer formed by corneocytes (keratinocytes that have migrated from the basal layer to the very top of the skin and acquired a phenotype of terminally differentiated, denucleated cells).

The barrier structure of the stratum corneum in human skin has four major components, from the inside of cornified cells to the outside: (i) keratin, filaggrin, involucrin and loricrin and their degradation products filling the cytoplasm of cornified cells, (ii) the cornified cell envelope (CCE), (iii) the corneocyte lipid envelope (CLE) and (iv) the intercellular lipid layers [6]. Of these structures, the CLE and the intercellular lipid layers consist of essential epidermal lipid components. Ceramides are one of the three major lipid classes (among free fatty acids and cholesterol/chol-esters), each representing approximately about one third of the total SC lipids and this specific composition is required to form the highly ordered lipid lamellae, which are crucial for the barrier function.

The extracellular space of cornified cell layers is occupied by multiple lipid layers called "intercellular lipid layers" that consist mainly of ceramides (50%), cholesterol (25%) and free fatty acids (10%-20%) with very little phospholipid [2, 4, 5, 7] arranged in parallel layers (lamellae) between the corneocytes and is essential for permeability barrier. Next to the lipid matrix originating from lamella bodies of corneocytes, sebum secreted by sebaceous gland also contributes to the overall lipid profile at the surface of the stratum corneum.

The corneocytes are filled with water, keratins and a mixture of highly hygroscopic substances known as natural moisturizing factor (NMF) [6, 8]. The water-binding property of NMF contributes to the hydration of the stratum corneum, which is essential for hydrolytic enzymatic processes, required for normal desquamation to take place [6].

The stratum corneum thus is a complex structure, which integrity and barrier function depends on cohesion of corneocytes, the presence and organization of lipids between them and their water-holding capacity.

#### 3.1.2. IMPORTANCE OF SKIN BARRIER, LIPIDS AND WATER FOR COSMETIC- AND MEDICAL DERMATOLOGY AND SKIN PHARMACOLOGY

Characterization of the skin barrier is of central importance in several fields including dermatology, skin pharmacology and personal care. Skin barrier function is affected

in patients with extensive list of dermatological diseases including lamellar ichthyosis, psoriasis, Netherton syndrome, Chanarin-Dorfman and atopic dermatitis (AD) [9] and has been suggested to play a role in sensitive skin [10–12].

For example, barrier defect abnormalities (contributing to increased transepidermal water loss in addition to increased allergen exposure), such as a shared filaggrin mutation were noted in ichthyosis vulgaris [6] and atopic dermatitis, where reduced structural proteins and lipids (e.g., ceramides), have been discovered as well [13]. Altered composition of epidermal lipids was also found to be correlated with *Staphylococcus aureus* colonization status in atopic dermatitis [14]. It was also proposed that information on biomarkers including lipids could be essential in distinguishing allergic contact dermatitis from other types of dermatitis, for example irritant and atopic dermatitis [15]. In psoriatic skin, a chronic inflammatory disease associated with a variety of co-morbid conditions, including cardiovascular disease, heterogeneity in lipid/protein composition at the micrometer scale [16] and changes in TEWL, free fatty acids and sebum [17] have been reported. In skin pharmacology, new transdermal drug delivery methods have to overcome the skin barrier while maintaining its integrity [18] or deliver optimized formulations [19].

In personal care, skin care and shaving routines, such as shaving, exfoliation, microdermabrasion, and hair removal, need to carefully balance their effectiveness and mildness towards SC barrier in order to prevent excessive discomfort and skin irritation. Looking from a perspective of cosmetic dermatology, alterations in skin water holding capacity, water and lipids concentrations are thought to be implicated in aging skin [20] and in dry skin [21]. To continue, in cosmetic industry, skin appearance is traditionally and at least partly judged based on skin oiliness or/and glossy appearance, where the latter one is caused by a presence of emulsified film composed of lipids of sebum, cornfield envelope, cosmetics and environment pollution with sweat [22, 23]. While extensive skin oiliness or/and gloss are often attributed to decreased appearance, their suboptimal levels are associated with itchy and dry-feeling skin, which looks lusterless, erythematous, and scaly [24, 25].

### 3.1.3. NEED IN QUANTIFICATION OF SKIN BARRIER, LIPIDS AND WATER

All this requires *in vivo*, non-invasive, quantitative tools assessing skin barrier function and in particular its water and lipid composition. Furthermore a continuously increasing demand towards personalized-aesthetics treatments [26], further emphasizes a need for non-invasive, quantitative skin measurements of the stratum corneum water and lipids.

### 3.1.4. STATE OF THE ART METHODS FOR QUANTIFICATION OF SKIN LIPIDS AND WATER

In the past years, quantification of the amount and composition of the extracted stratum corneum has been performed using a range of different methods such as weighing, optical spectroscopy, electron microscopy, X-ray diffraction [27]. For example, electron microscopy and X-ray diffraction studies have been carried out to investigate the degree of organization of intercellular lipids and its composition [28]. An optical method based on measurement of the pseudo absorption determined by scattering, reflection

and diffraction of the corneocytes in the visible range was described by Weigmann et al. [29].

Several easy-to-use and high throughput in vivo non-invasive methods for skin barrier assessment are well accepted in the dermatologist's office and in the mainstream of the cosmetic industry. They include transepidermal water loss (TEWL)-, capacitance- and conductance measurements for assessment of skin water content and its water-holding capacity and Sebumeter and gloss meter for assessment of skin lipids and gloss [30, 31].

The simplicity of these traditional, easy-to-use techniques comes, however, at a cost of their specificity. The data interpretation is not straightforward, as read-outs might be affected by external and internal factors not taken into account by these techniques. In particular, in the case of the electrical techniques, substances or treatments that interact with the keratin-water network of the stratum corneum can change the electrical properties of the skin without actually altering the water content [32]. Moreover, despite the apparent ease of use, measurements have to be performed under strictly controlled conditions in order to obtain reliable results, minimizing the influence of biasing factors, such as ambient temperature and humidity as well as skin appendages [33, 34].

Also knowing that the stratum corneum is a non-uniform, inhomogeneous membrane, the question "whether the lipid and water composition is distributed uniform across the stratum corneum thickness?" is not well addressed by existing methods. In particular, quantitative information on how the lipid and water composition changes with the depth in the stratum corneum is very limited.

In contrast, optical method based on light absorption and/or scattering by specific molecules, such as Raman microspectroscopy [35, 36] is well known for their chemical specificity and high spatial resolution and, thus, are inherently superior to traditional indirect electrical methods. Until now, confocal Raman microspectroscopy remains to be the gold standard for non-invasive quantitative, spatially-resolved measurements of concentration profiles of molecular components through the skin, including water and lipids. Confocal Raman microspectroscopy has been successfully used for several dermatological applications. With further developments for reducing the cost, CRS has the potential to enter the mainstream of clinical and dermatological practice with even wider range of applications [37–40].

### 3.1.5. SHORT WAVE INFRARED SPECTROSCOPY FOR QUANTIFICATION OF LIPIDS AND WATER IN THE STRATUM CORNEUM

Near-infrared microspectroscopy is an alternative lower cost approach to confocal Raman microspectroscopy for quantification of the molecular composition of the skin. While this technique offers far less molecular specificity compared to Raman scattering, near-infrared microspectroscopy can provide quantitative and molecular-specific information on water and lipids in the skin-two components that play an important role in skin condition (e.g., oily skin versus dry skin) as well as skin barrier and its disorders.

Recently we reported two highly sensitive optical methods for quantitative assessment of the skin gloss in the low value regime of relevance for daily applications [41]. Subsequently, we reported preliminary results demonstrating the feasibility of a novel non-invasive optical method for simultaneously measuring the hydration and sebum re-

taining ability of the skin [42]. The methods rely on the detection of signals at three carefully selected wavelengths in the spectral region around 1720 nm, with ratio of sebum-to-water absorption coefficient greater than 1; lower than 1 and an 'isosbestic point', where lipids and water absorb equally.

To gain spectroscopic information from the deeper layers of stratum corneum, we used tape-stripping, a well-established method for the investigation of skin permeability and barrier function, evaluation of dermatological disorders and assessment of penetration profile and efficacy of various cosmetic and dermatological formulations.

As a follow-up, in this study, we show the feasibility of short wave infrared spectroscopy as a novel method for analyzing the stratum corneum components, lipids and water, as a function of depth where the stratum corneum layers were removed using a double-sided adhesive tape. We also compared the results with the gold standard of skin measurements, confocal Raman spectroscopy, and with traditionally accepted, mainstream biophysical devices such as Corneometer, TEWL and Sebumeter.

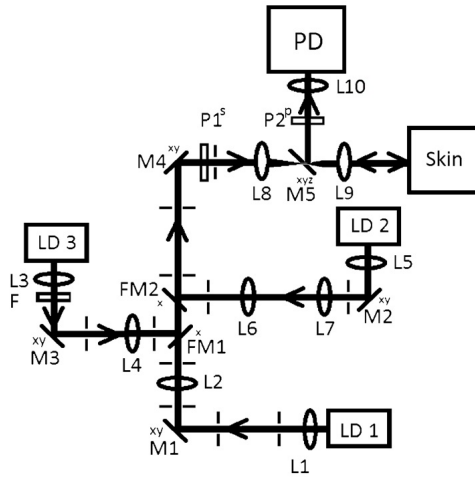
### 3.2. MATERIALS AND METHODS

The study was approved by an internal ethics committee, the Internal Committee for Biomedical Experiments (ICBE) and the volunteer provided written informed consent. Data was acquired on the forehead (T-zone) of a female volunteer (26 years old) with no history of atopic dermatitis, asthma, allergy, contact dermatitis, or any other skin disorders. The forehead region was chosen because it represents a skin area with a high density of sebaceous glands with medium level of hydration.

D-Squame<sup>®</sup> Sampling Disc (CuDerm Corporation, Dallas, USA) with the diameter 30.16 mm was applied for tape stripping. The exerted pressure on the tape was controlled by the D-Squame pressure instrument at 225 gr/cm<sup>2</sup> for 10 seconds. Tapes were removed by fast movement with D-Squame angular tweezers to ensure minimal variations in the conditions of tape stripping and in the amount of skin removed.

The developed infrared spectroscopic setup relies on skin illumination using three laser sources and utilizes differential detection at  $1720 \pm 4$  nm,  $1750 \pm 5$  nm and  $1770 \pm 20$  nm wavelength. These specific wavelengths were previously selected as representative bands corresponding to the lipid vibrational bands that lay "in between" the prominent water absorption bands [42]. Following the logic, the wavelengths 1750 nm and 1770 nm were used for estimating the water content and 1720 nm and 1750 nm were used for estimating the lipid content. The amount of water and lipids is then calculated based on the ratio of backscattered light to the incident intensity using an algorithm based on Beer-Lambert's law. The setup and algorithms are described in more detail elsewhere [42].

The relative amount of water and lipids content in the stratum corneum with respect to the baseline were measured after each tape stripping with the shortwave infrared spectroscopic experimental set-up, Corneometer CM825 (Courage & Khazaka, Köln, Germany), AquaFlux Transepidermal water loss (TEWL) instrument (Biox Systems Ltd, Herts, England) and Sebumeter SM815 (Courage & Khazaka, Köln, Germany). These reference biophysical devices were used according to instructions given in the corresponding user manuals. Data were acquired five times in a row with all devices (SWIR, CRS, Corneometer, TEWL, Sebumeter) within a small area of investigation (6 cm<sup>6</sup>).



**Figure 3.1:** Schematic of the short wave infrared experimental set-up [42]: LD1 - Laser Diode ( $1720 \pm 4$  nm, Roithner Laser), LD2 - Laser Diode ( $1750 \pm 5$  nm, Roithner Laser), LD3 - Laser Diode ( $1770 \pm 20$  nm, Roithner Laser), F - Narrowband filter ( $1770 \pm 5$  nm, Spectrogon), M1, M2, M3, M4 - mirrors, M5 - Mirror with a central aperture, FM1, FM2 - Flipping mirrors, L1, L3, L5 - Aspheric lenses, L2 ( $f = 300$  mm), L4 ( $f = 300$  mm), L6 ( $f = 75$  mm), L7 ( $f = 150$  mm), L8 ( $f = 35$  mm), L9 - Plano convex lenses L9 ( $f = 35$  mm) - Biconvex lens, L10 ( $f = 25.4$  mm, LA1951-C) P1<sup>S</sup>, P2<sup>P</sup> - polarizers, PD - photodiode (DET30B/M).

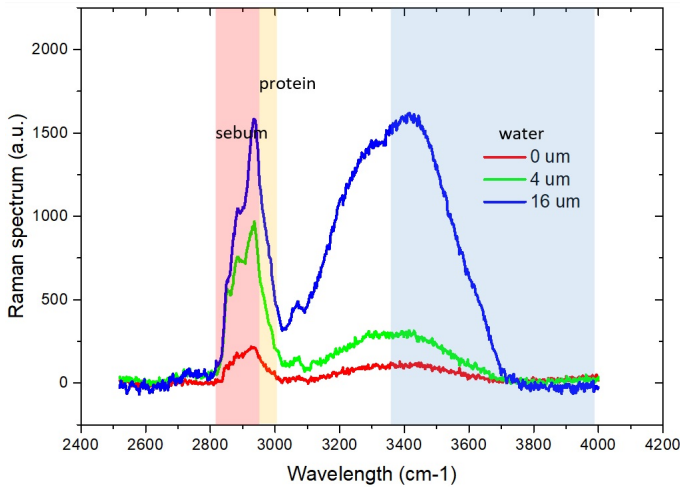
To obtain benchmark (or gold standard) values for the water and lipids concentrations as a function of depth, confocal Raman microspectroscopy measurements were performed (using an inverted confocal Raman microspectrometer gen2-SCA equipped with 785 nm and 671 nm laser sources, model RiverICon 4.0 instrument control, RiverD International B.V., Rotterdam, The Netherlands). The system was previously described in detail elsewhere [43, 44]. Raman spectra were obtained over a depth range of  $30 \mu\text{m}$ , starting from the skin surface and at an axial resolution of  $2 \mu\text{m}$ . For each depth, measurements were performed at 10 different lateral locations ( $50 \mu\text{m}$  apart) to average out the intrinsic spatial variation of molecular composition at a microscopic scale. SkinTools 2.0 software (RiverD International B.V., Rotterdam, The Netherlands) was used for spectral analysis. Lipid and water content was calculated based on lipid to protein (keratin) and water to protein (keratin) ratio's, respectively (lipid:  $2790\text{-}2910 \text{ cm}^{-1}$ ; protein:  $2910\text{-}2966 \text{ cm}^{-1}$ ; water:  $3350\text{-}3550 \text{ cm}^{-1}$ ) [43].

### 3.3. RESULTS

Raman spectra measured at three different axial positions in the skin ( $0$ ,  $4$  and  $16 \mu\text{m}$  with respect to the surface of the SC) together with spectral regions with preferential signal of water ( $3350\text{-}3550 \text{ cm}^{-1}$ ), protein ( $2910\text{-}2966 \text{ cm}^{-1}$ ) and sebum/lipid ( $2790\text{-}2910 \text{ cm}^{-1}$ ) are shown in Figure (3.2). It can be seen from the Figure 2 that there is a very low water signal at the top surface of the stratum corneum and just below the skin ( $0$  to  $4 \mu\text{m}$  depth with corresponding physiological concentration of approximately 25%).

The spectra at 0 and 4  $\mu\text{m}$  can also be measured within the thin layer of sebum or at the sebum-skin interface. A notably strong water signature is appearing at a depth corresponding to the boundary between the SC and the viable epidermis (approximately 10-15  $\mu\text{m}$  below the skin surface, where the water concentration in healthy skin reaches about 65%). These experimental findings are fully in line with what is known from the literature [45].

As for the lipids, their clearly visible spectral signature both at the skin surface and at a depth of 4  $\mu\text{m}$  is notable, while at a deeper location (16  $\mu\text{m}$ ) the spectral band 2790-2966  $\text{cm}^{-1}$  becomes dominated by proteins, i.e., lipid content is decreasing. Relatively high contribution of lipids to the spectra acquired from the superficial layers originates from a mixture of intercellular lipids of corneocytes and components secreted by the sebaceous glands. Note that in the regions of high density of sebaceous glands such as T-zone (where the measurements have been performed), the contribution of epidermal components is very low (3-6%). At the same time, at body locations with sparse presence of the sebaceous glands, epidermal lipids are expected to leverage a larger contribution to the overall lipid signal.

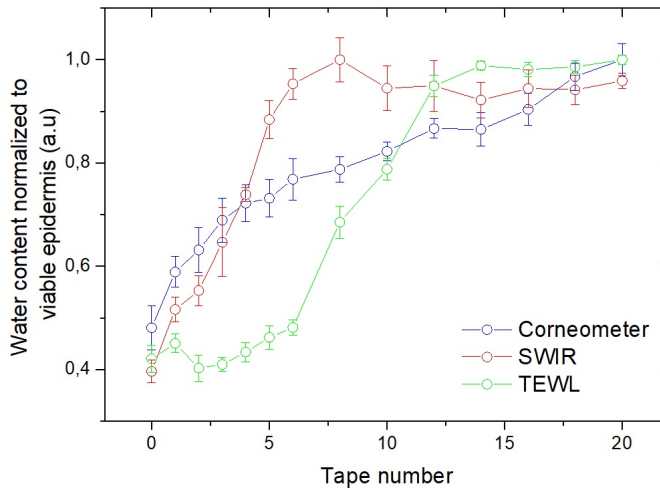


**Figure 3.2:** Raman spectra of the stratum corneum acquired at three axial positions, 0, 4 and 16  $\mu\text{m}$ . Spectral regions with preferential contribution of water (3350-3550  $\text{cm}^{-1}$ ), protein (2910-2966  $\text{cm}^{-1}$ ) and sebum/lipid (2790-2910  $\text{cm}^{-1}$ ) are marked.

The results of water and lipid content measurement as a function of tape strip number using the proposed SWIR method, together with the corresponding data acquired using Corneometer, TEWL are shown in Figures (3.3) and (3.4). The water content is normalized with respect to the maximum value corresponding to 70% water content in viable epidermis and lipid content is normalized with respect to the maximum value corresponding to the lipid content measured at the skin surface before tape stripping. Corresponding depth resolved water and lipid measurements using confocal Raman micro spectrometer is shown for comparison. Except for Raman spectroscopy, all other methods require tape stripping to obtain depth resolved information because these measure-

ment systems do not have inherent depth resolution required for depth profiling.

As was expected, one can observe an increase in the level of the SC hydration with an increase in the number of the removed tape strips, as corneocytes with higher amount of water become ‘exposed’ to the probes used in SWIR, Corneometer and TEWL measurements. As for the overall shape of the water concentration profile, it shows a very steep initial rise corresponding to the first 6-8 tapes, where the barrier function got impaired as shown by corresponding TEWL readings, which shows abrupt increase in water flux [46]. Our findings are fully in line with previously reported water concentration profile across the SC of human subjects obtained using electron-probe analysis [47] and confocal Raman microscopy [48].



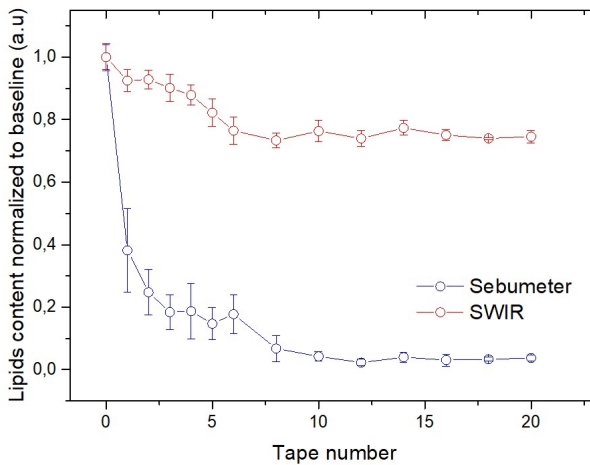
**Figure 3.3:** Relative Stratum corneum water content normalized with respect to the maximum value (70% water) as a function of tape-strip number measured with SWIR, Corneometer and TEWL.

In contrast to the profiles measured using SWIR, capacitance increase with depth is almost linear in the low hydration regime of the nearly intact skin (corresponding to up to five tapes removed), while changes to exponential growth when the barrier function is impaired (in a depth region corresponding to ~30% increase of TEWL values [52]). Similar results for the capacitance measurements were previously demonstrated by Boncheva et. al, where the authors hypothesized that these linear and exponential regions reflect different proton mobilities in bound and liquid/free water (where the water molecules are tightly bound to SC keratins at lower water content up to 40 mass% and are present in unbound state at high water content [49]). This suggests that once the skin barrier has been impaired by tape stripping, it is not clear whether the increase in capacitance and SWIR measurements are related to a higher water content of the deeper layers or to an increased water flux induced by tape stripping, as shown by the increased TEWL readings. Therefore, the electrical and SWIR measurements when used in combination with tape stripping for depth profiling need to be applied in combination with the measurement of TEWL [50].

The results of lipid content measurement as a function of tape strip number using the proposed SWIR method, together with the corresponding data acquired using Sebumeter are shown in Figure (3.4). Each dataset shows a relative lipid content, where the data were normalized with respect to the maximum value measured at the very surface of the skin, prior to tape stripping, where lipids of the SC envelope, of corneocytes and of sebum contribute to the overall signal). The corresponding depth-resolved profile acquired using confocal Raman micro-spectrometer in non-disturbed intact skin is shown for comparison as a gold standard/ground truth in Figure (3.5).

One notices a very similar trend in the depth-resolved data obtained using the SWIR and the Raman spectroscopy methods: both show an almost linear decrease in the lipid signal over the first 10 micrometers, followed by a nearly steady-state plateau. This is specific for the T-zone where physiologically a thin layer of sebum content is expected.

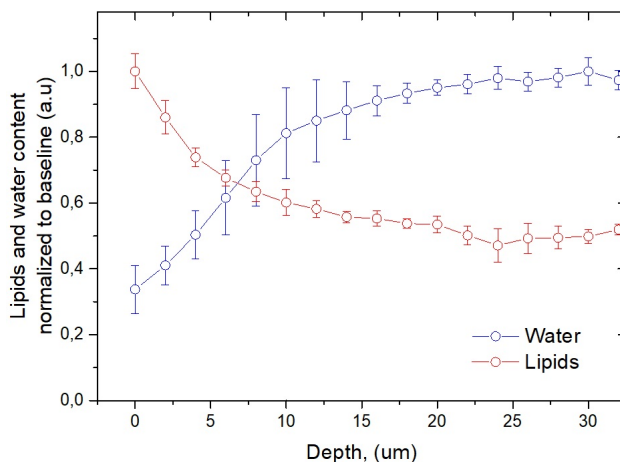
This lipid signal across the SC measured using SWIR after a thin layer of sebum was removed is in line with what is known about their deposition by epidermal keratinocytes. The latter are delivering lipids to construct the cornified envelope by exocytosis of lamella bodies organelles at the boundary between the SC and the viable epidermis [4, 6].



**Figure 3.4:** Relative Stratum corneum lipid content normalized with respect to the baseline (no-strip) as a function of tape-strip number measured with SWIR and Sebumeter.

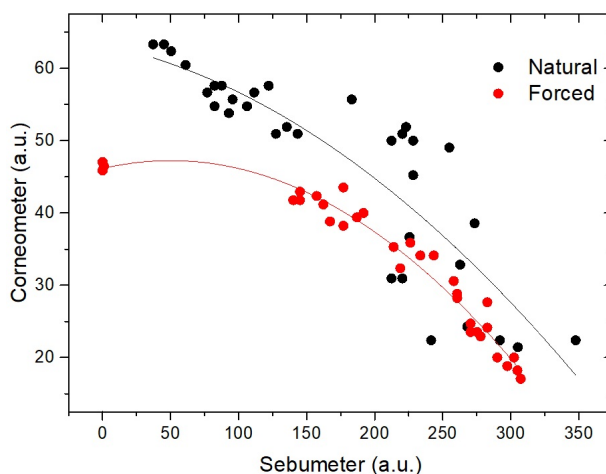
Figure (3.6) shows the dependence of capacitance based skin hydration measurements using the Corneometer to measure the presence of lipids. The baseline skin hydration value was measured on the T-zone having casual sebum levels (250-300 units measured with Sebumeter) and hydration measurements were repeated while the amount of sebum on the skin surface was gradually removed. We observe that skin hydration values increases (Figure (3.6), black line) by a factor of two as the sebum levels drops from 250-300 to 50-60 Sebum units measured with the Sebumeter. Figure (3.5) (red line) shows the decrease in the baseline skin hydration measured with the Corneometer as we gradually apply a thin layer of artificial sebum on the skin surface, in a range relevant for physiological values. We observe that skin hydration drops by a factor of three as





**Figure 3.5:** Depth resolved relative stratum corneum water and lipid content normalized with respect to the baseline measured with confocal Raman micro spectrometer for comparison.

the amount of sebum was increased from 0 to  $1.2 \mu\text{l}/\text{cm}^2$  on the skin surface, indicating the influence of sebum on hydration measurements.



**Figure 3.6:** Dependence of capacitance based skin hydration measurements using Corneometer on the presence of skin surface lipids (sebum).

### 3.4. DISCUSSION

We quantify the depth profile of SC lipids and hydration using short wave infrared spectroscopy combined with tape stripping and compare the results with conventional biophysical devices such as Corneometer, Sebumeter, AquaFlux TEWL and Confocal Raman spectrometry, which provides the gold standard. The method of tape stripping in

combination with short wave infrared spectral analysis presented in this study demonstrate a simple and noninvasive method for the analysis of intercellular lipids and the degree of hydrogen bonding (or hydration) as a function of depth in the SC. The results show that the SC is a non-uniform membrane, characterized by gradients of the water and lipid content.

Regarding non-invasive methods reported for monitoring water content in the skin in vivo, instruments based on transepidermal water loss properties [51], dielectric properties such as conductance and capacitance [52] and spectroscopic techniques, such as near-infrared spectroscopy [36], and Confocal Raman microscopy [38] have been used. Even though conductance and capacitance based hydration measurements are cheap and portable, these measurements give only relative water content, not absolute values as in the case of Confocal Raman. The relationship between electrical properties and water content is highly complex and nonlinear. The device readings using electrical measurements are affected by the presence of sebum, sweat, hairs, surface microtopography and other environmental factors such as humidity and temperature. The measurement of hydration level of the stratum corneum obtained with the capacitance method can be affected by the presence of a thin layer of lipids (sebum) and also moisturized creams, having lower value of dielectric constant.

This is expected because when a thin layer of oil or artificial sebum having very low dielectric constant ( $\epsilon_r \sim 3$ ) is present in the probing depth of the Corneometer, which is typically in the range of few tens of microns, the hydration of skin based on the relatively high dielectric constant of water ( $\epsilon_r \sim 80$ ) can be influenced. Furthermore, the sensitivity of the capacitance-based method in the low hydration regime is limited. In addition, water present in the skin can be tightly bind, bind and not bind and therefore the variation in water binding strength can lead to poor correlation between total water content and electrical conductance [52]. The electrical methods based on capacitance and conductance give an integrated value of the SC hydration, rather than the actual water distribution of the superficial epidermal layers. In addition, it is not clear whether the increased water content measured with electrical measurements during tape stripping is due to high water content of the deeper SC layers or because of the water flux induced by tape stripping [50]. However, electrical devices and methods can be used to distinguish between dry SC, normal SC and highly hydrated SC.

The transepidermal water loss (TEWL) is used as an indirect measure to characterize the thickness of the SC layer. This method is inaccurate, especially for tape strips removed from the superficial layers of the stratum corneum. In addition, emulsions or creams applied on the skin surface can influence the TEWL. TEWL measurements suggest a high influx of water after about striping half of the stratum corneum.

Unlike depth resolved Confocal Raman measurements, the amount of lipids and water content measured with SWIR and other biophysical devices do not directly reflect the individual layer contents because of the probing depth of these devices. The results rather correspond to a weighted average over the outermost few layers because these measurement systems do not have inherent depth resolution like Confocal Raman. Except for Raman measurements that was done in intact skin, all other measurements were done in combination with tape stripping to get depth information and this will impair the barrier function and in particular can influence the water content compared to intact

water measurements performed with Confocal Raman. In addition, as the skin hydration changes with SC depth, the refractive index of the skin, its absorption and consequently the penetration depth of the beam also change. The amount of lipid and water content per layer could be quantitatively determined by measuring the attenuation characteristics of each tape as a function of depth. Compared to Raman measurements, all other devices have to be used in combination with tape stripping to get depth information. Nevertheless, the trends observed in the measurements and the general nature of the behavior obtained remain unchanged.

Several non-invasive *in vivo* methods such as solvent extraction, cigarette paper pads, photometric assessment, bentonite clay, and lipid-sensitive tapes have been developed to quantify skin surface lipid parameters: sebum casual level, sebum excretion rate, sebum replacement time, instant sebum delivery, follicular excretion rate, and sustainable rate of sebum excretion. Sebometry, based on photometric measurement technique is an established photometric method in the diagnostic practice and in clinical trials, as they are time-saving and highly reproducible. The lipids near the surface represent a mixture of true intercellular lipids and sebaceous lipids. The amount and composition of the skin surface lipids is a mixture of epidermal and sebaceous components. Epidermal lipids originate from the maturing corneocytes and are liberated at the skin surface during the normal desquamation process where the terminal keratinocytes exfoliate. The amount and composition of the intracellular lipids change during the maturation process of the keratinocyte [53]. Sebaceous lipids containing large quantities of relatively low -melting-point fatty acids delivered to the skin surface is attenuated quite quickly as one proceeds (through the sequential tape-stripping) into the membrane [54]. The relative ratio of these two components depends on the density of sebaceous glands and therefore on the body locations. In the regions of high density of sebaceous glands such as in the T-zone, the contribution of epidermal components is very low (3-6%) whereas in sebaceous glands sparse body regions epidermal lipids have a more significant influence on the lipid mixture [55]. Sebum present on the surface may be high as 100 to 500  $\mu\text{g}/\text{cm}^2$ , compared with the low quantities of epidermal lipids, which can vary in the range of 5-10 to 25-40  $\mu\text{g}/\text{cm}^2$  [55]. Sebometer is sensitive only to the non-bound skin surface sebaceous lipids and epidermal lipids present in the first one or two layers. The decreases in SC lipid content observed in spectroscopic measurements may be also reflected due to the increase in the fractional volume occupied by the corneocytes with increasing depth. This observation is consistent with previously reported microscopic histology, which showed dense corneocytes surrounded by relatively large amounts of lipid near the skin surface and larger corneocytes with smaller intercellular spaces deeper in the membrane [56, 57].

Until now, no non-contact devices and methods except confocal Raman spectroscopy have been reported for the quantitative and simultaneous measurement of stratum corneum lipids and water content. Development of a non-contact method for measuring stratum corneum hydration and lipids simultaneously will enable to assess the balance between these factors related to skin health and to select the appropriate dermatological treatment and provide personalized skin treatment solutions. This will also enable to classify the skin types into Normal skin (N), Dry skin (D), Oily Skin (O), Oily-Hydrated skin (OH) and oily-dry skin (OD) and select appropriate water or oil based

skin care products and to monitor the progress during treatment. Confocal Raman microscopy has developed as a powerful tool for analyzing the depth dependent physicochemical properties of the SC, providing valuable information on the water and intercellular content [58]. Even though Confocal Raman is a highly reliable method for direct and spatially resolved depth profiling of water and lipid content, the commercially available devices are expensive. More recently, this technique was further applied for analyzing the intercellular lipid conformation and the lipid lateral packing order which are directly linked to an impaired skin barrier function and skin diseases, such as atopic eczema, psoriasis [9].

Compared to Sebumeter measurements that is sensitive to surface lipids only, short wave infrared spectroscopic method is sensitive to both bound and non-bound lipids and therefore makes it possible to measure the changes for lipids present in stratum corneum during tape stripping. One of the potential advantages of the proposed optical method is that it is insensitive to the presence and variation of other skin chromophores such as blood and melanin and can be applied independent of skin type. Moreover, the probe does not need to be in contact with the skin so that the repeated measurements can be performed on the same location without changing the skin conditions.

### 3.5. CONCLUSION

In this chapter, we quantify changes in skin hydration and lipids using short wave infrared spectroscopic set-up combined with tape stripping and compare the results with conventional biophysical devices such as Corneometer, Sebumeter and AquaFlux TEWL. The preliminary results demonstrate the feasibility of the novel optical method for simultaneously measuring the hydration and sebum retaining ability of the skin as a function of tape strip number during tape stripping. Compared to Confocal Raman measurements, all other measurement devices including SWIR need to be used in combination with tape stripping, as these measurement devices do not have inherent depth resolution. Furthermore, changes in the stratum corneum barrier function and the corresponding increase in the flux of water occurring during tape stripping suggest that these measurement devices need to be used in combination with TEWL for quantitative estimation of water content. Confocal Raman and shortwave infrared spectroscopic measurements show that the SC barrier in terms of the intercellular lipid and the degree of hydration is not uniform across the entire thickness: the outer few layers appear to be less hydrated and contains increased amount of intercellular lipids than the deeper layers of the membrane. We conclude that the short wave infrared spectroscopic technique combined with tape stripping can be used for analyzing the stratum corneum components and thereby provide more quantitative and more reliable skin barrier function information than conventionally employed electrical methods.

## REFERENCES

- [1] A. Ezerskaia, N. Uzunbajakava, G. Puppels, J. de Sterke, P. Caspers, H. P. Urbach, and B. Varghese, *Potential of short-wave infrared spectroscopy for quantitative depth profiling of stratum corneum lipids and water in dermatology*, *Biomedical Optics Express* **9**, 2436 (2018).
- [2] D. J. Tobin, *Introduction to skin aging*, *Journal of Tissue Viability* **26**, 37 (2017).
- [3] C. Arck, A. Slominski, T. C. Theoharides, E. M. Peters, and R. Paus, *Neuroimmunology of stress: skin takes center stage*, *Journal of Investigative Dermatology* **126**, 1697 (2006).
- [4] K. R. Feingold, P. M. Elias, and M. Peter, *Role of lipids in the formation and maintenance of the cutaneous permeability barrier*, *Biochim Biophys Acta* **1841**, 280 (2014).
- [5] D. J. Tobin, *Biochemistry of human skin-our brain on the outside*, *Chem Soc Rev* **1841**, 52 (2006).
- [6] M. Akiyama, *Corneocyte lipid envelope (cle), the key structure for skin barrier function and ichthyosis pathogenesis*, *J Dermatol Sci* **88**, 3 (2017).
- [7] K. C. Madison, *Barrier function of the skin: "la raison d'etre" of the epidermis*, *J Invest Dermatol* **121**, 231 (2003).
- [8] A. Watabe, T. Sugawara, K. Kikuchi, K. Yamasaki, S. Sakai, and S. Aiba, *Sweat constitutes several natural moisturizing factors, lactate, urea, sodium, and potassium*, *J Dermatol Sci* **72**, 177 (2013).
- [9] J. van Smeden, M. Janssens, G. S. Gooris, and J. A. Bouwstra, *The important role of stratum corneum lipids for the cutaneous barrier function*, *Biochim Biophys Acta* **1841**, 295 (2014).
- [10] R. J. Richters, D. Falcone, N. E. Uzunbajakava, B. Varghese, P. J. Caspers, G. J. Puppels, P. E. van Erp, and P. C. van de Kerkhof, *Sensitive skin: assessment of the skin barrier using confocal raman microspectroscopy*, *Skin Pharmacol Physiol* **30**, 1 (2017).
- [11] R. J. Richters, D. Falcone, N. E. Uzunbajakava, W. Verkruysse, P. E. van Erp, and P. C. van de Kerkhof, *What is sensitive skin? a systematic literature review of objective measurements*, *Skin Pharmacol Physiol* **28**, 75 (2015).
- [12] R. J. Richters, N. E. Uzunbajakava, D. Falcone, J. C. Hendriks, E. J. Jaspers, P. C. van de Kerkhof, and P. E. van Erp, *Clinical, biophysical and immunohistochemical analysis of skin reactions to acute skin barrier disruption - a comparative trial between participants with sensitive skin and those with nonsensitive skin*, *Br J Dermatol* **174**, 1126 (2016).
- [13] M. Sullivan and N. B. Silverberg, *Current and emerging concepts in atopic dermatitis pathogenesis*, *Clinics in Dermatology* **35**, 349 (2017).

- [14] S. Li, M. Villareal, S. Stewart, J. Choi, G. Ganguli-indra, D. C. Babineau, G. David, T. Yoshida, M. Boguniewicz, J. M. Hanifin, L. A. Beck, D. Y. Leung, E. L. Simpson, and A. K. Indra, *Altered composition of epidermal lipids correlates with staphylococcus aureus colonization status in atopic dermatitis*, *Br J Dermatol* **177**, e125 (2017).
- [15] S. A. Koppes, K. A. Engebretsen, T. Agner, I. Angelova-Fischer, T. Berents, J. Brandner, R. Brans, M. L. Clausen, E. Hummler, I. Jakasa, R. Juraki?-Ton?ic, S. M. John, D. Khnykin, J. O. Molin, J. O. Holm, S. Suomela, H. J. Thierse, S. Kezic, S. F. Martin, and J. P. Thyssen, *Current knowledge on biomarkers for contact sensitization and allergic contact dermatitis*, *Contact Dermatitis* **77**, 1 (2017).
- [16] M. Leroy, T. Lefevre, M. A. Pouliot, and G. Laroche, *Using infrared and raman microspectroscopies to compare ex vivo involved psoriatic skin with normal human skin*, *J Biomed Opt* **20**, 067004 (2015).
- [17] H. Takahashi, H. Tsuji, M. Minami-Hori, Y. Miyauchi, and H. Iizuka, *Defective barrier function accompanied by structural changes of psoriatic stratum corneum*, *J Dermatol* **41**, 144 (2014).
- [18] M. Z. Prausnitz and R. Langer, *Transdermal drug delivery*, *Nat Biotechnol* **26**, 1261 (2008).
- [19] R. Daniels, *Basic therapeutics: What are the features of modern personal care products to protect and regenerate the skin barrier?* *Hautarzt* **68**, 912 (2017).
- [20] A. R. Parrish, *The impact of aging on epithelial barriers*, *Tissue Barriers* **5**, e1343172 (2017).
- [21] A. Pons-Guiraud, *Dry skin in dermatology: a complex physiopathology*, *J Eur Acad Dermatol Venereol* **21**, 1 (2007).
- [22] N. Samson, B. Fink, and P. J. Matts, *Visible skin condition and perception of human facial appearance*, *Int J Cosmet Sci* **32**, 167 (2010).
- [23] T. Igarashi, K. Nishino, and S. K. Nayar, *The appearance of human skin: a survey*, *Foundations and Trends@in Computer Graphics and Vision* **32**, 1 (2007).
- [24] A. O. Barel, M. Paye, and H. I. Maibach, *Handbook of Cosmetic Science and Technology* (CRC Press, 2009).
- [25] M. A. Gupta and A. K. Gupta, *Dissatisfaction with skin appearance among patients with eating disorders and non-clinical controls*, *British journal of dermatology* **145**, 110 (2001).
- [26] A. E. Rizzo and H. I. Maibach, *Personalizing dermatology: the future of genomic expression profiling to individualize dermatologic therapy*, *J. Dermatolog. Treat* **23**, 161 (2012).
- [27] R. Marks, J. L. Leveque, and R. Voegeli, *The Essential Stratum Corneum* (CRC Press, 2001).

- [28] M. A. Lampe, A. L. Burlingame, J. Whitney, M. L. Williams, B. E. Brown, and P. M. Elias, *Human stratum corneum lipids: characterization and regional variations*, *J Lipid Res* **24**, 120 (1983).
- [29] H. J. Weigmann, J. Ulrich, S. Schanzer, U. Jacobi, H. Schaefer, W. Sterry, and J. Lademann, *Comparison of transepidermal water loss and spectroscopic absorbance to quantify changes of the stratum corneum after tape stripping*, *Skin Pharmacol Appl Skin Physiol* **18**, 180 (2005).
- [30] G. E. Nilsson, *Measurement of water exchange through skin*, *Med. Biol. Eng. Comput.* **15**, 209 (1977).
- [31] H. Tagami, M. Ohi, K. Iwatsuki, Y. Kanamaru, M. Yamada, and B. Ichijo, *Evaluation of the skin surface hydration in vivo by electrical measurement*, *J. Invest. Dermatol* **75**, 500 (1980).
- [32] R. Pethig and D. B. Kell, *The passive electrical properties of biological systems: their significance in physiology, biophysics and biotechnology*, *Phys Med Biol* **32**, 933 (1987).
- [33] G. Martinsen, S. Grimnes, and J. Karlsen, *Electrical methods for skin moisture assessment*, *Skin Pharmacol Physiol* **8**, 237 (1995).
- [34] B. Cravello and A. Ferri, *Relationships between skin properties and environmental parameters*, *Skin Res Technol* **14**, 180 (2008).
- [35] Z. Movasaghi, S. Rehman, and I. U. Rehman, *Raman spectroscopy of biological tissues*, *Appl. Spectrosc. Rev.* **42**, 493 (2007).
- [36] H. W. Siesler, Y. Ozaki, S. Kawata, and H. M. Heise, *Near-Infrared Spectroscopy: principles, instruments, applications* (Wiley-VCH, 2002).
- [37] D. Cialla-May, X. S. Zheng, K. Weber, and J. Popp, *Recent progress in surface-enhanced raman spectroscopy for biological and biomedical applications: from cells to clinics*. *Chem. Soc. Rev.* **46**, 3945 (2017).
- [38] H. U. Gremlich and B. Yan, *Infrared and Raman spectroscopy of biological materials* (CRC press, 2001).
- [39] D. W. Shipp, F. Sinjab, and I. Notingher, *Raman spectroscopy: techniques and applications in the life sciences*, *Advances in Optics and Photonics* **9**, 315 (2017).
- [40] K. Guze, H. C. Pawluk, M. Short, H. Zeng, J. Lorch, C. Norris, and S. Sonis, *Pilot study: Raman spectroscopy in differentiating premalignant and malignant oral lesions from normal mucosa and benign lesions in humans*, *Head & Neck* **37**, 511 (2015).
- [41] A. Ezerskaia, A. Ras, P. Bloemen, S. F. Pereira, H. P. Urbach, and B. Varghese, *High sensitivity optical measurement of skin gloss*, *Biomed Opt Express* **8**, 3981 (2017).

- [42] A. Ezerskaia, S. F. Pereira, H. P. Urbach, R. Verhagen, and B. Varghese, *Quantitative and simultaneous non-invasive measurement of skin hydration and sebum levels*, *Biomed Opt Express* **7**, 2311 (2016).
- [43] P. J. Caspers, H. A. Bruning, G. J. Puppels, G. W. Lucassen, and E. A. Carter, *In vivo confocal raman microspectroscopy of the skin: noninvasive determination of molecular concentration profiles*, *J Investig Dermatol* **116**, 434 (2001).
- [44] J. Lademann, G. W. Lucassen, P. J. Caspers, and G. Puppels, *Infrared and raman spectroscopy of human skin in vivo*, *Handbook of Optical Biomedical Diagnostics*, Second Edition, Vol 2: Methods, (2016).
- [45] P. Caspers, *In vivo skin characterization by confocal Raman microspectroscopy*, Ph.D. thesis, Erasmus University Rotterdam (2003).
- [46] Y. Gao, X. Wang, S. Chen, S. Li, and X. Liu, *Acute skin barrier disruption with repeated tape stripping: an in vivo model for damage skin barrier*, *Skin Res Technol* **19**, 162 (2013).
- [47] R. R. Warner, M. C. Myers, and D. A. Taylor, *Electron probe analysis of human skin: determination of the water concentration profile*, *J Investig Dermatol* **90**, 218 (1988).
- [48] M. Egawa, T. Hirao, and M. Takahashi, *In vivo estimation of stratum corneum thickness from water concentration profiles obtained with raman spectroscopy*, *Acta Dermato-Venereologica* **87**, 4 (2007).
- [49] C. Choe, J. Lademann, and M. E. Darvin, *Depth profiles of hydrogen bound water molecule types and their relation to lipid and protein interaction in the human stratum corneum in vivo*, *Analyst* **141**, 6329 (2016).
- [50] M. Boncheva, J. de Sterke, P. J. Caspers, and G. J. Puppels, *Depth profiling of stratum corneum hydration in vivo: a comparison between conductance and confocal raman spectroscopic measurements*, *Exp Dermatol* **18**, 870 (2009).
- [51] J. Pinnagoda, R. A. Tupkek, T. Agner, and J. Serup, *Guidelines for transepidermal water loss (tewl) measurement: a report from the standardization group of the european society of contact dermatitis*, *Contact Dermatitis* **22**, 164 (1990).
- [52] C. W. Blichmann and J. Serup, *Assessment of skin moisture. measurement of electrical conductance, capacitance and transepidermal water loss*, *Acta Dermato Venereologica* **68**, 284 (1988).
- [53] M. Ponc, A. Weerheim, J. Kempenaar, A. M. Mommaas, and D. H. Nugteren, *Lipid composition of cultured human keratinocytes in relation to their differentiation*, *J Lipid Res* **29**, 949 (1988).
- [54] G. W. Lu, S. Valiveti, J. Spence, C. Zhuang, L. Robosky, K. Wade, A. Love, L. Y. Hu, D. Pole, and M. Mollan, *Comparison of artificial sebum with human and hamster sebum samples*, *Int J Pharm* **367**, 37 (2009).



- [55] V. R. Wheatley, *The sebaceous glands*, The physiology and pathophysiology of the skin, vol 9, A. Jarrett, ed. (1986).
- [56] I. Brody, *A light and electron microscopy study of normal human stratum corneum with particular reference to the intercellular space*, Upsala J Med Sci **94**, 29 (1989).
- [57] A. Z. Menton, D. N. anad Eisen, *Structure and organization of mammalian stratum corneum*, J Ultrastruct Res **35**, 247 (1971).
- [58] N. Nakazawa, N. Ohta, and I. Hattabc, *A possible regulation mechanism of water content in human stratum corneum via intercellular lipid matrix*, Chem Phys Lipids **165**, 238 (2012).

# 4

## HIGH SENSITIVITY OPTICAL MEASUREMENT OF SKIN GLOSS\*

*We demonstrate a low-cost optical method for measuring the gloss properties with improved sensitivity in the low gloss regime, relevant for skin gloss properties. The gloss estimation method is based, on one hand, the slope of the intensity gradient in the transition regime between specular and diffuse reflection and on the other hand on the sum over the intensities of pixels above threshold, derived from a camera image that is obtained using unpolarized white light illumination. We demonstrate the improved sensitivity of the two proposed methods using Monte Carlo simulations and experiments performed on ISO gloss calibration standards with an optical prototype. The performance and linearity of the method was compared with different professional gloss measurement devices based on the ratio of specular to diffuse intensity. We demonstrate the feasibility for in-vivo skin gloss measurements by quantifying the temporal evolution of skin gloss after application of standard paraffin cream bases on skin. The presented method opens new possibilities in the fields of cosmetology and dermatopharmacology for measuring the skin gloss and resorption kinetics and the pharmacodynamics of various external agents.*

---

\*Parts of this chapter have been published in Biomedical Optics Express **8**, (9), 3981-3992 (2017) [1].

## 4.1. INTRODUCTION

Quantitative assessment of the appearance of human skin resulting from complex optical interactions involving surface specular and subsurface diffuse reflections has been a subject of great interest in the fields of dermatology, cosmetology, and computer graphics [2–6]. In dermatology, the assessment of the appearance of the diseased area by the dermatologist is the first and most important step in the diagnosis of dermatological disorders [7]. In cosmetology, the skin radiance associated with subsurface diffuse reflections is a desired skin-beauty attribute whereas skin gloss associated with specular surface reflections is unfavorable [8]. The appearance of skin is significantly influenced by the presence of a thin emulsified film on the skin surface. Sebum containing lipids from sebaceous glands and epidermal keratinocytes is mixed with sweat and other lipids from cosmetics and environment to form this emulsified film of refractive index higher than that of the epidermis [9, 10]. This thin layer of skin surface lipids provides barrier protection, regulation of transepidermal water loss and maintenance of the skin biofilm [11–13]. Even though multiple physiological functions of sebum are proposed, sebum is associated with large pore size and the formation of comedonal and inflammatory acne lesions [14]. Sebum causes the skin to look glossier due to higher Fresnel reflection and smooth air-sebum interface. Glossy and oily skin is considered to be unaesthetic and unpleasant and often associated with various dermatological disorders such as seborrhea, acne and hormonal imbalance. In sebum deficit conditions, the skin is vulnerable to infections and it feels itchy, dry, and looks lusterless, erythematous, and scaly. Optimal balance between sebum production and requirements imparts a non-glossy and healthy feel to the skin and is dermatologically and cosmetically desirable [14–17]. As a result strategies are being developed to balance the needs of the skin to its optimal lipid requirements by controlling the sebum secretion rate and to monitor the skin condition using non-invasive optical devices and methods.

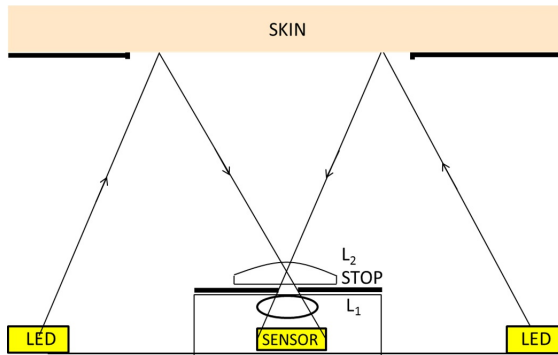
Skin gloss measurements resulting from specular reflections depend on the physical properties of the skin, such as refractive index, texture and device characteristics, such as device geometry, angle of incidence and polarization of the incident radiation [18, 19]. The refractive index of the skin generally decreases with increased hydration of the skin and thus the skin moisture condition also contribute to the overall gloss/appearance of the skin. Right balance between hydration (moisture) and sebum (skin surface lipids) is an indication of healthy skin and plays a central role in protecting and preserving skin health. Many professional and home-use devices are currently available for measuring skin sebum and hydration levels. Recently, we reported for the first time a non-invasive short wave infrared spectroscopic technique for simultaneous measurement of oiliness and hydration levels of the skin utilizing the differential detection with three wavelengths 1720, 1750, and 1770 nm, corresponding to the lipid vibrational bands that lay “in between” the prominent water absorption bands [20].

Many products are currently entering the marketplace to reduce sebum production and overall facial gloss reduction. The gloss measurement is an established and standardized procedure in paint and surface coating industry [21–23]. However, until now only very limited non-contact devices and methods have been reported for the quantitative measurement of skin gloss and the visual grading method remains the main tool for evaluating gloss attributes.

The presently used methods for skin gloss measurements are based on the ratio of specular to diffuse intensity. The sensitivity of this method in the low gloss regime relevant for skin gloss characteristics is lower than in the high gloss regime. In this article, we report on two highly sensitive optical methods for quantitative assessment of the skin gloss in the low gloss regime relevant for many applications in cosmetology and dermatopharmacology. The two methods are based on the angle or slope of the intensity gradient in the transition regime between specular and diffuse reflection of the intensity profile along the optical axis in the specular to diffuse transition region and on the number of pixels above a threshold weighted with its intensity. We have used Monte Carlo ray tracing simulations using the LightTools software to calculate the gloss for a full range of samples from 100% specular (mirror) to 100% diffuse (Diffuse standard). We have developed an optical prototype and experiments were performed on ISO calibration standards and the results are compared with an industrial gloss meter (Gardner Micro-Tri-Gloss). In-vivo skin gloss measurements were performed for different gloss conditions and the temporal evolution of skin gloss after the application of different standards cream bases were compared with professional skin gloss measurement devices (SAMBA, C&K Skin gloss meter).

## 4.2. MATERIALS AND METHODS

### 4.2.1. EXPERIMENTAL SET-UP



**Figure 4.1:** Schematic of the system model used for the Monte Carlo simulation and the optical prototype.

The imaging optics is based on a low-cost raspberry pi camera module using unpolarized white light illumination (Fig. 4.1). The skin is sequentially illuminated using four unpolarized white light sources (Luxeon Z white, Lumileds LXZ1-4070) at an angle of incidence with the normal of approximately  $22^\circ$ . A Pi camera imaging sensor of a fixed focus color camera with  $2592 \times 1944$  pixels were used to reduce the processing overhead. To achieve a field of view of about  $10 \times 7.5$  mm and a focus at 10 mm, we placed a  $f = 10$  mm lens on the top of this unit. The stop size of the camera is 1.16 mm and to achieve a larger depth of focus we placed a stop of diameter 0.6 mm between the camera module lens and the f10 lens. The depth of focus and resolving power of the final prototype were

611  $\mu\text{m}$  and 10  $\mu\text{m}$  respectively.

#### 4.2.2. MONTE CARLO SIMULATIONS

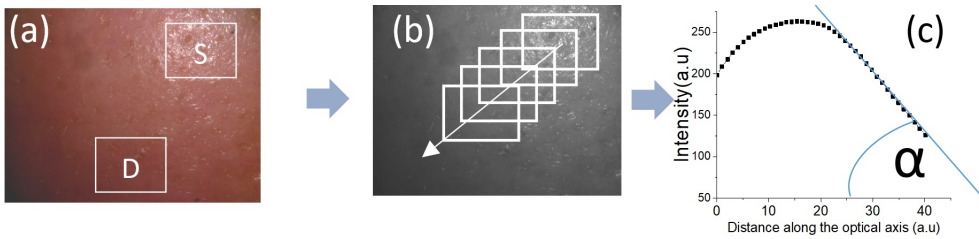
Monte Carlo ray tracing simulations were performed using LightTools software package. The Monte Carlo simulations calculate the photometric and radiometric quantities to perform a complete illumination and detection analysis. The optical configuration of the system used in simulation was based on the optical configuration of the prototype described in Section 4.2.1. A black box was used around the sensor to prevent signal contribution from the walls that directly hit the sensor without having interacted with the skin. The skin sample is modelled using a surface having a 17% reflectivity. We investigated the full range from 100% specular (mirror) to 100% diffuse (Diffuse standard) by using a phenomenological model for the skin such that all reflection takes place at the air/skin interface. We have modelled the LUXEON LXZ1 4070 LED (color temperature of 4000 K and CRI of 70) as a Lambertian surface emitter and having a package that has 90% diffuse reflectivity. The LED surface is of 70% diffuse reflectivity and zero transmission. The printed circuit board is modelled as having a 60% diffuse reflectivity and zero transmission. The walls of the housing and the STOP surface have been modelled as black but not a perfectly black but having 5% diffuse reflectivity and zero transmission. The lenses are modelled having refractive indices corresponding to the N-LASF9 and the N-BK7 glass in the visible region for the larger and smaller lens, respectively.

#### 4.2.3. IMAGE PROCESSING ALGORITHMS FOR GLOSS ESTIMATION

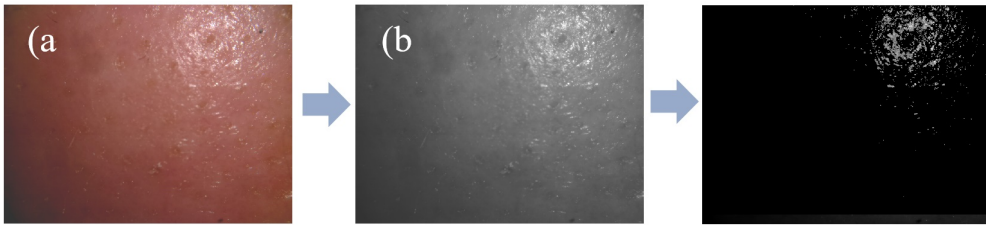
We used two approaches for estimating gloss value from the image. The methods are based on the angle (slope) of the intensity profile as a function of distance in the transition region from specular spot to diffuse background and the number of pixels above a threshold weighted with the corresponding pixel intensity.

To calculate the angle (slope), the following steps are followed. The RGB image is converted to a gray scale image in MatLab by forming a weighted sum of the R, G, and B components. First a window is selected in the region of the specular reflection, and the average intensity of in this region of interest is calculated as a function of distance in the specular to diffuse transition regime and the last window is selected to be in the area of diffuse reflection (Fig. 4.2a). The desired number of windows is built along the line connecting the centers of the first and the last windows (Fig. 4.2b). The average intensity is calculated for every window. The averaged intensity values are plotted as function of the spatial coordinate of the window. Close to the specular reflection region linear regression is applied to estimate the slope of the curve (Fig. 4.2c) and the angle between resulting tangent to the curve and the horizontal axis is used as indicator of surface gloss. Higher gloss of the surface contributes to a higher specular component and a resulting curve of average intensities that has a larger slope, leading to a higher value for the angle.

For the method based on the number of pixels above a threshold weighted by the intensities, the RGB image (Fig. 4.3a) is first converted to a gray scale image in MatLab by forming a weighted sum of the R, G, and B components (Fig. 4.3b). We sum the intensities of all pixels whose intensity is above the threshold (i.e. the pixels shown in (Fig. 4.3c). This results in a gloss value.



**Figure 4.2:** Schematic representation of gloss measurement method based on the angle (slope) of the intensity profile in the transition region from specular spot (S) to diffuse background (D).



**Figure 4.3:** Schematic representation of gloss measurement method based on the number of pixels above a threshold weighted with intensity.

The gloss value calculated using the method presented here are compared with the method based on the ratio of the specular to diffuse reflection, used in traditional gloss measurement devices such as Gardner Gloss meter (Micro-Tri-Gloss) and Skin gloss meter (Courage & Khazaka).

#### 4.2.4. CALIBRATION USING REFERENCE STANDARDS

In traditional gloss measurement devices, the angle of incidence (AOI) and the optical geometry used for gloss measurements depend on the gloss property of the sample. Typically, the sample is first measured in a  $60^\circ$  geometry. If the gloss value is higher than 70 G.U. (high gloss), then it is re-measured at  $20^\circ$ , and, if the gloss value is less than 10 G.U. (low gloss), it is re-measured at  $85^\circ$ . The reason for this procedure is that the high accuracy is obtained by using  $85^\circ$  for low-gloss samples,  $60^\circ$  for semi-gloss samples, and  $20^\circ$  for high-gloss samples.

We used three highly polished reference black glass standards (Novo Gloss) with a defined refractive index having a known ISO reference gloss units of 10.2, 21.9 and 52.3 G.U. at an angle of illumination of  $60^\circ$  as 'calibration tiles' or 'calibration standards' in the high gloss regime. The gloss values of these calibration tiles were first measured using a professional industrial gloss meter (Gardner) at an angle of illumination of  $60^\circ$  and was found to be in the range of mid to high gloss value range (between 10 and 70 G.U.). These calibration standards have assigned gloss unit values for the angle of  $60^\circ$  and are traceable to BIN standard for Material Research. We have used different industrial gloss papers to measure the performance and linearity of our method for low gloss value samples. The gloss values of these paper samples measured with Gardner (AOI =  $60^\circ$ ) were

less than 10 G.U, corresponding to the low gloss regime. The measurement results obtained with the camera prototype on calibration tiles and gloss papers were compared with the gloss values measured with Gardner for AOI = 60°.

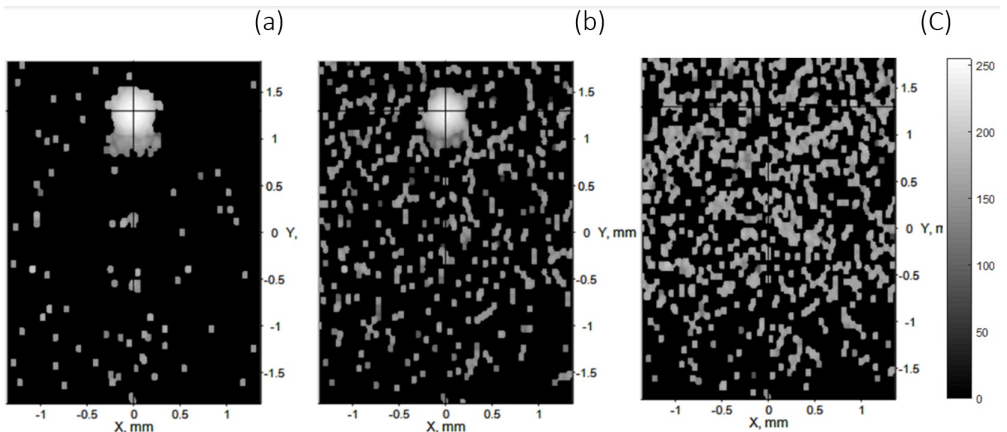
#### 4.2.5. IN-VIVO SKIN GLOSS MEASUREMENTS

In-vivo measurements were performed for different gloss conditions of the skin. We quantified the evolution of skin gloss on the forehead after the application of liquid paraffin which cause various levels of gloss. Reference gloss measurements were performed using a professional whole-face image gloss measurement device from Bossa Nova Technologies, SAMBA and skin gloss meter from Courage & Khazaka. SAMBA consists of a high resolution digital camera equipped with a liquid-crystal polarizer, the polarization angle of which can be electronically flipped from the direction parallel ( $P$ ) to the plane of polarization of the polarizing filters on the illumination units to crossed ( $C$ ) orientation. A Region of Interest (ROI) in the "T-zone" area of the face was chosen for the measurement. SAMBA device measures polarization state on each pixel in the entire ROI and then calculates the average value of calculate gloss ( $P-C$ ) and gloss degree ( $P-C / P+C$ ).

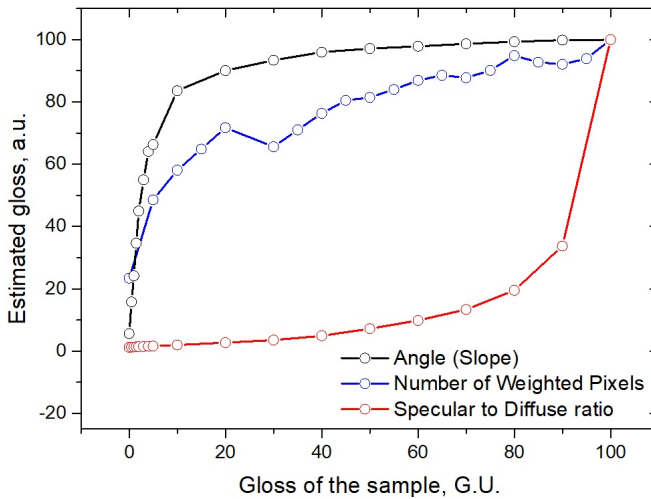
### 4.3. RESULTS

#### 4.3.1. MONTE CARLO SIMULATIONS

Figure (4.4) shows the examples of simulated power density distributions on the sensor for three different gloss values. As the gloss value of the sample is changed from a 100% specular (Fig. 4.4a) to 100% diffuse (Fig. 4.4c), the magnitude of the specularly reflected light drops whereas the diffuse background signal increases. Figure. (4.5) shows the gloss value estimated using the methods based on slope, weighted sum over pixels above threshold and specular to diffuse ratio.



**Figure 4.4:** The power distribution on the sensor obtained for different gloss values using Monte Carlo simulations: (a) 100% Glossy, (b) 50% Glossy / 50% Diffuse, (c) 100% Diffuse. The grey values are the logarithm of the power density.



**Figure 4.5:** The gloss value estimated using Monte Carlo ray tracing for samples with gloss values ranging from 0% (diffuse standard) to 100% (mirror).

The results of comparing both methods to the standard ratio between specular and diffuse reflection show that the sensitivity of our two methods is high for samples in the low gloss regime and in particular for samples with glossiness in the range from 0 to 20% (Fig. 4.5). Therefore we expect that our methods are very suitable for measuring gloss values of skin, since, unlike material surfaces in industry, these are low and change only within a very small range. On the other hand, the sensitivity of the traditional specular to diffuse intensity ratio method is high for high gloss samples.

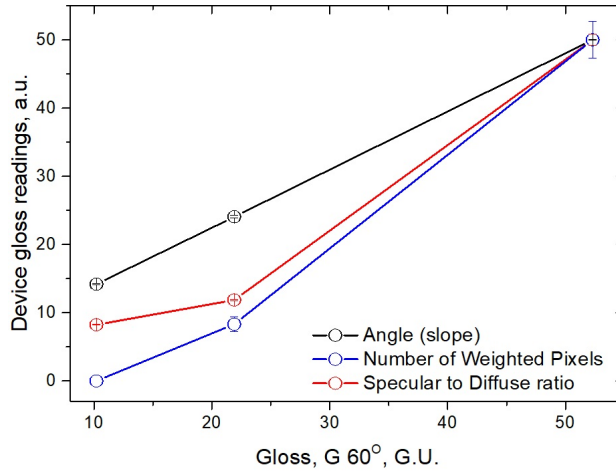
#### 4.3.2. MEASUREMENTS ON ISO GLOSS CALIBRATION STANDARDS

Figure (4.6) shows the comparison of the gloss value measured with our two new methods on ISO calibration tiles having high gloss, with the gloss values obtained with the Gardner professional gloss meter using an angle of illumination of  $60^\circ$ . The same comparison done for low gloss samples is shown in Figure.(4.7). We observe that the measurement sensitivity of the different methods depends on the gloss value of the samples. For lower gloss values, the measurement sensitivity of the slope method and the method based on the number of weighted pixels are higher than that of ratio of specular and diffuse reflection. In the case of samples with medium gloss values, the method based on the number of weighted pixels and the ratio of specular to diffuse reflection are more sensitive than the angle method. These observations are consistent with the results of Monte Carlo simulations described in Section (4.3.1).

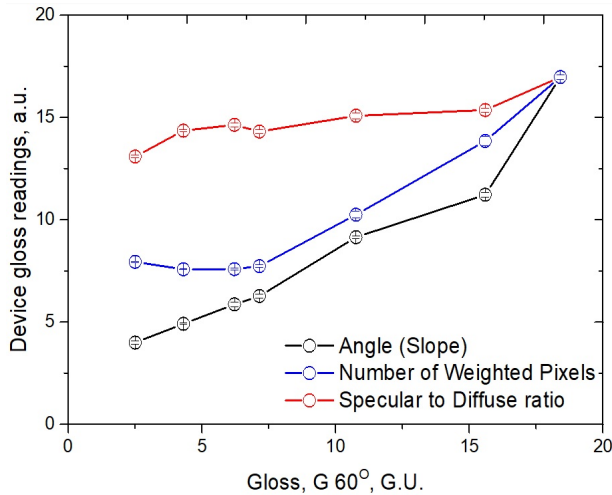
#### 4.3.3. IN-VIVO SKIN GLOSS MEASUREMENTS

Figure (4.8) shows the temporal evolution of skin gloss value after the application of liquid paraffin to the skin. The results obtained using our optical prototype are compared with professional gloss measurements devices such as Courage & Khazaka and SAMBA. The temporal evolution of the gloss value of all skin measurement methods give



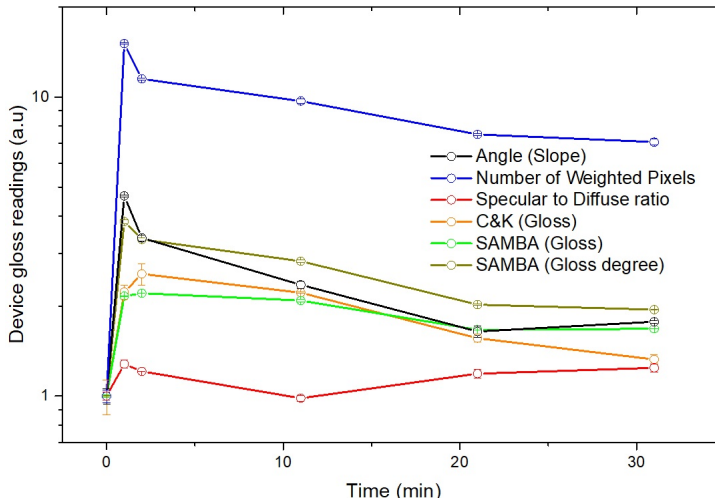


**Figure 4.6:** The gloss values estimated on ISO Gloss calibration tiles in the high gloss regime measured with the camera prototype and algorithms and comparison to professional Gloss meter measurements using angle of illumination of  $60^\circ$ .



**Figure 4.7:** The gloss values estimated on gloss papers in the low gloss regime measured with the camera prototype and algorithms and comparison to professional Gloss meter measurements using angle of illumination of  $60^\circ$ .

increased gloss value within the first minute after the application of paraffin. Paraffin is applied in a liquid form, which spreads on the skin surface beyond the application area. Such a behavior results in a decrease in the gloss value with time in the area of interest [24].



**Figure 4.8:** The temporal evolution of skin gloss values after application of liquid paraffin. Experimental results obtained with the camera prototype are compared with professional devices for skin gloss measurements.

#### 4.4. DISCUSSION

Here we present two new optical methods for measuring the gloss characteristics of skin with high sensitivity in the low gloss regime, unlike the high gloss material samples used in industry. The sensitivity of current gloss meters used in industry is rather limited in particular for skin gloss measurements where gloss is low. The low-cost optical method presented permits fast, contactless and randomly repeatable quantitative measurement of skin gloss, which can be used for defining the acceptance criteria for various external agents that can cause greasy and glossy appearance to the skin. This opens new possibilities in the fields of cosmetology and dermatopharmacology for measuring skin gloss and for analyzing the resorption kinetics and the pharmacodynamics of various external agents. Our new method can also test with high sensitivity the acceptance of various cosmetic and pharmaceutical products that are used for influencing the skin gloss conditions.

The sensitivity of the gloss measurement devices strongly depends on the measurement geometry and currently, different angle of illumination are used in industry depending on the gloss levels.  $85^\circ$  AOI is more sensitive to differences in the low gloss regime (gloss below 10 GU) whereas  $20^\circ$  AOI has higher sensitivity for high gloss samples (gloss above 70 GU). The detectable differences in gloss depends on the gloss level of the sample and the consumer relevance of these detectable differences depends on how many units of gloss units would be subjectively perceived as significantly different. For instance 3.0 GU difference measured on a very matt surface with a gloss value below 10 GU would be seen by the human eye but on a higher gloss sample with a gloss value above 70 GU the difference would be very difficult to notice.

Our initial results show that a single camera device with two algorithms, can be used for measuring a broad range of gloss values without any hardware modifications for the

angle of illumination. The two algorithms based on slope estimation and the number of weighted pixels above threshold show high sensitivity in the low-gloss regime whereas the traditional method based on the ratio of specular to diffuse reflection shows high sensitivity in the high-gloss regime. The algorithm based on the number of weighted pixels gives reasonably good sensitivity for both low and high gloss samples.

The high-gloss regime is characterized by predominant specular reflection. The reflection tends to become nearly an image of the light source for high gloss samples. The intensity profile along the optical path does not change significantly with variation of the gloss value of the surface in high gloss regime. Therefore, the angle (slope) of the intensity profile also does not change significantly. The recorded intensity of the light source reflection yet becomes higher with increase in gloss value of the reflecting surface, while the diffuse component of the reflection decreases. Therefore the method based on the ratio of specular to diffuse reflection is more sensitive for samples with high gloss. However, such high gloss values do not occur for skin.

Our in-vivo experimental results show that our method is able to discriminate between different gloss levels that are physiologically relevant for skin. As expected, methods based on estimation of the angle or slope of the intensity profile and the method based on the sum of weighted pixels show high sensitivity to the temporal evolution of the gloss value of the skin, in particular in the low gloss regime. The method based on the ratio of specular and diffuse reflection is not sensitive enough to detect changes in the skin gloss because the gloss values are too low. However with the Samba professional gloss camera changes in the skin gloss values can be detected. The Courage & Khazaka Glossmeter based on specular reflection estimation with correction on diffuse component, is sufficiently sensitive to skin gloss changes even in the low-gloss regime. The reason may be the geometry of the sensor. Traditionally gloss meters used in the paint industry and for coatings are produced with light source and detector that are spatially separated by several centimeters. The Courage & Khazaka Glossmeter probe has a geometry where the distance between source and detector is few mm, so that the diffuse reflected light can be detected.

The experimental results obtained on calibration standards and gloss papers using the prototype show good agreement with the Gardner professional gloss measurement device. The measurement sensitivity obtained on calibration samples with uniform surface properties may deteriorate when experiments are performed on skin with anticipated non-uniform surface properties and low gloss values. Also, the measurement of skin gloss using our set-up can, like any other optical gloss measurement method, be influenced by for example, skin color, the extend of skin doming depending on the applied pressure and the amount of sebum, sweat, etc., on the skin surface. Skin color probably will give only an effect of intensity difference in blue, green or red channels and can be compensated by auto intensity correction in a final system.

When unpolarized light is reflected by a skin surface, the polarization properties of the reflected light depends on the angle of illumination. ISO and ASTM standards for gloss measurements do not describe the conditions for polarization in the illumination and detection path. Previous reports on the polarization effects for gloss measurements showed significant effect of polarization on Fresnel reflectance of the black-glass reference standard. When the angle of illumination is close to polarizing angle or the Brewster

angle of about  $57^\circ$ , strong polarization effects may occur in gloss measurements. However, in our current optical geometry using small angle of illumination of about  $23^\circ$ , the magnitude of the polarization error is expected to be smaller than that for large angles of incidence.

The micro-gloss measurements realized with our camera prototype in a maximum field of view of few  $\text{cm}^2$  may not be the same as the human visual perception of skin gloss, where the whole face is viewed. Nevertheless, our gloss measurements show good correlation with the corresponding small area measurements derived from the full face gloss image measured with SAMBA. Due to the relatively large illumination and viewing beam field angle of a camera prototype resulting from the divergence of LED source, we expect that our method may correlate better to the gloss scale derived from visual perception than the point measurements using collimated narrow beam small spot gloss measurements. The number of pixels weighted with intensity approach could be used in "gloss mapping mode" to instantly represent the spatial distribution of the gloss of a complex, pixel by pixel whereas methods based on slope and on the ration of specular to diffuse reflection only give an average gloss value.

## 4.5. CONCLUSION

We report a low-cost optical method with improved sensitivity for the quantitative assessment of the gloss of human skin in the low gloss regime relevant for skin gloss conditions. We have used Monte Carlo simulations, experiments on gloss calibration standards and in-vivo skin gloss experiments to demonstrate the improved sensitivity of the proposed method in the low gloss regime compared to traditional skin gloss measurement methods. Experimental results obtained with the optical prototype and the algorithms that we have developed, were compared with professional industrial gloss meter and professional skin gloss measurement devices. The proposed method opens new possibilities for fast, contact less quantitative assessment of the skin gloss in the low gloss regime in the fields of cosmetology and dermatopharmacology in measuring the resorption kinetics and the pharmacodynamics of various external agents.

## REFERENCES

- [1] A. Ezerskaia, A. Ras, P. Bloemen, S. F. Pereira, H. P. Urbach, and B. Varghese, *High sensitivity optical measurement of skin gloss*, Biomedical Optics Express **9**, 3981 (2017).
- [2] J. Ripoll, D. Yessayan, G. Zacharakis, and V. Ntziachristos, *Experimental determination of photon propagation in highly absorbing and scattering media*, JOSA A **22**, 546 (2005).
- [3] W. Ji, M. Pointer, R. Luo, and J. Dakin, *Gloss as an aspect of the measurement of appearance*, JOSA A **23**, 22 (2006).
- [4] A. Ponticorvo, D. Burmeister, B. Yang, B. Choi, R. Christy, and A. Durkin, *Quantitative assessment of graded burn wounds in a porcine model using spatial frequency domain imaging (sfdi) and laser speckle imaging (lsi)*, Biomed Opt Express **5**, 3467 (2014).
- [5] N. Samson, B. Fink, and P. J. Matts, *Visible skin condition and perception of human facial appearance*, Int J Cosmetic Sci **32**, 167 (2010).
- [6] A. Matsubara, Z. Liang, Y. Sato, and K. Uchikawa, *Analysis of human perception of facial skin radiance by means of image histogram parameters of surface and subsurface reflections from the skin*, Skin Res Technol **18**, 265 (2012).
- [7] J. Huff, W. Weston, and M. Tonnesen, *Erythema multiforme: A critical review of characteristics, diagnostic criteria, and causes*, J Am Acad Dermatol **8**, 763 (1983).
- [8] W. van Lankveld, M. Vonk, H. Teunissen, and F. van den Hoogen, *Appearance self-esteem in systemic sclerosis—subjective experience of skin deformity and its relationship with physician-assessed skin involvement, disease status and psychological variables*, Rheumatology **46**, 872 (2007).
- [9] L. Li and C. Ng, *Rendering human skin using a multi-layer reflection model*, Int J Math Comp Simulat **1**, 44 (2009).
- [10] H. Ding, J. Lu, K. Jacobs, and X. Hu, *Determination of refractive indices of porcine skin tissues and intralipid at eight wavelengths between 325 and 1557 nm*, JOSA A **22**, 1151 (2005).
- [11] D. Downing, *Lipid and protein structures in the permeability barrier of mammalian epidermis*, J. Lipid Res. **33**, 301 (1992).
- [12] A. Jarrett, *The Physiology and Pathophysiology of the Skin* (Academic Press, 1986).
- [13] P. Elias and G. Menon, *Structural and lipid biochemical correlates of the epidermal permeability barrier*, Adv. Lipid Res. **24**, 1 (1991).
- [14] P. Pochi, J. Strauss, and D. Downing, *Skin surface lipid composition, acne, pubertal development, and urinary excretion of testosterone and 17-ketosteroids in children*, J Invest Dermatol **69**, 485 (1977).

- [15] B. Kim, J. Choi, K. Park, and S. Youn, *Sebum, acne, skin elasticity, and gender difference - which is the major influencing factor for facial pores?* *Skin Res Technol* **19**, e45 (2013).
- [16] W. Abramovits and A. Gonzalez-Serva, *Sebum, cosmetics, and skin care*, *Derm Clin* **18**, 617 (2000).
- [17] W. Cunliffe and S. Shuster, *The rate of sebum excretion in man*, *Brit J Derm* **81**, 697 (1969).
- [18] R. Silvennoinen, K. Peiponen, and K. Myller, *Specular gloss* (Elsevier, 2008).
- [19] A. Pfund, *The measurement of gloss*, *JOSA A* **20**, 23 (1930).
- [20] A. Ezerskaia, S. F. Pereira, H. P. Urbach, B. Verhagen, and B. Varghese, *Quantitative and simultaneous non-invasive measurement of skin hydration and sebum levels*, *Biomedical Optics Express* **7**, 2311 (2016).
- [21] R. S. Hunter and R. W. Harold, *The Measurement of Appearance* (John Wiley & Sons, 1987).
- [22] M. Matsuta and T. Kubota, *Gloss measurement on painted surfaces*, *Jap J Appl Phys* **20**, 1145 (1981).
- [23] G. Kigle-Boeckler, *Measurement of gloss and reflection properties of surfaces*, *Mat. Finish* **93**, 28 (1995).
- [24] A. Lentner and V. Wienert, *A new method for assessing the gloss of human skin*, *J Skin Pharmac* **9**, 184 (1996).



# 5

## CONCLUSIONS AND OUTLOOK

*In this chapter a summary of the results and conclusions are given. An outlook to future developments is presented, which will translate the novel methodology developed in this project.*



## 5.1. CONCLUSIONS

Skin condition can be largely characterized by its barrier function state. This function is primarily based on the balance between water and lipids content and holding capacity on a certain skin layer. The high importance of this balance fueled the development of numerous water and lipids measurement methods and devices based on invasive and non-invasive approaches, some of them even allow for depth profiling of the measured substance. Nevertheless, those methods aim for a measurement of either water or lipids, while rather the balance of those is important to determine the overall skin state.

The research presented in this thesis proposes several methods for assessing a number of skin conditions, such as dryness, oiliness, hydration and combinations of those, induced skin dryness and oiliness condition analogous to eczema and psoriasis, as well as various states of skin gloss within human physiological range and beyond.

Skin defensive function state defined by the ratio of water to lipids distributed throughout the Stratum Corneum is addressed by means of short wave infrared spectroscopy. The method is described in this thesis as well assists realization in an experimental set-up comprising 3 wavelengths sensitive to primarily lipids – 1720 nm, primarily water – 1770 nm and equally sensitive to both – 1740 nm [1]. The wavelengths are chosen in the spectral window virtually free of other chromophores, which is characterized by relatively low scattering constant of the skin in this spectral region [2–8]. Initially, the method was tested along with benchmark devices such as Corneometer [9] and Sebumeter [10] on various skin conditions which may be found naturally as well it was tested on enhanced conditions, which replicate common skin disorders by level of water and lipids present in the stratum corneum [11–21]. Measurements obtained using the proposed method and benchmark devices showed good agreement.

The method does not inherit depth resolution due to purposefully straightforward robust design to enable effortless miniaturization in the future. A widely used technique of tape stripping came handy in resolving depth profile of water and lipids in the bulk skin by removing a layer of stratum corneum at the time ensuring stepsize of 1  $\mu\text{m}$  per measurement. The differential spectroscopy approach at the same time allowed to quantify detected relative changes in hydration and lipids content and compare them to number of benchmark measuring devices such as Corneometer [9], Sebumeter [10], AquaFlux TEWL [22] and the golden standard of depth resolved components specific method - confocal Raman microscopy [23]. All methods show expectedly alike trends [24] indicating potential use of the proposed method for stratum corneum depth resolved water and lipids simultaneous measurements in the category of low-cost devices.

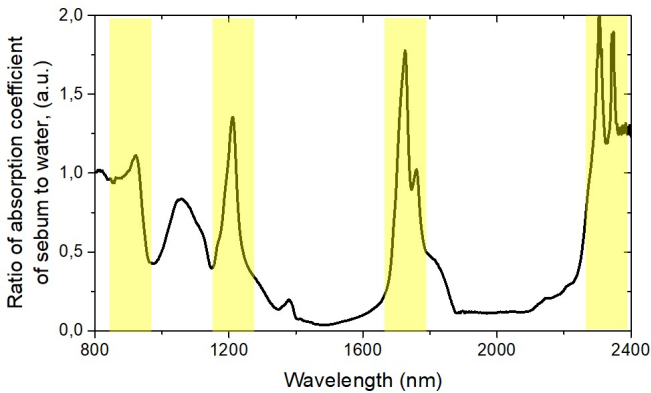
Additionally to skin well-being, appearance is not of the least importance. Skin appearance is characterized by several factors such as color, roughness and gloss [25–27]. Skin color and roughness measurements are extensively addressed in the modern market, while vast majority of standardized industrial gloss measuring devices and methods target areas not related to skin appearance or are being hardly affordable for general public. Consequently, low-cost method for quantifying skin appearance by measuring skin gloss was proposed in this thesis. The solution comprises a low-cost hand-held camera

combined with image analysis technique allowing estimation of specular and diffuse component in the reflection from the investigated surface determining the gloss value as the result. The method has been tested on Monte-Carlo simulation based on virtual phantoms representing wide variety of surfaces from low gloss, corresponding to mate skin, predominantly characterised by diffuse reflection all the way up to the mirror-like surfaces predominantly characterised by specular reflection. As well, the method has been tested on industrial standards for high and medium gloss values and compared to commercially available professional gloss meters [28] and additionally, the device and the algorithm were tested in-vivo on skin treated with standard cosmetics solutions, compared with commercially available skin gloss meters including the golden standard in the field - SAMBA differential polarisation camera. The method showed results comparable to the golden standard skin gloss meter performance in the low-gloss regime and, additionally, similar to industrial gloss meters performance was observed in the medium and high gloss regimes, which allows for versatile application of the method.

## 5.2. OUTLOOK

The described above methods can be further developed into a relatively compact device enabling measurements of the skin state in respect of its hydration, oiliness and gloss/appearance.

Potentially, the other region of the infrared spectrum can be used for low-cost applications. There are several regions with similar ratio of absorption coefficients of water and lipid in the spectral range from 800 nm to 2400 nm, as shown in Figure (5.1).



**Figure 5.1:** Ratio of absorption coefficient of sebum to water measured in the shown spectral range between 800 to 2400 nm. Yellow bands represent the optimal spectral bands for simultaneous hydration and sebum sensing defined by high absorption coefficients of water and sebum and a large ratio of the absorption coefficients to obtain high contrast.

Given the fact that gloss measurement aims to assess the appearance, which correlate to human vision in the visible range, the measurement principle as presented in this thesis could be preserved but with the wavelength being displaced to the shorter wavelengths, which can be detected by a Si-based camera. The skin water-lipid measurement

could be combined with the gloss measurement in the same device.

There are suitable spectral regions that can be used for skin characterization both in the infra-red and in the near infrared parts of the spectrum, as showed in Figure (5.1). Peaks in the infrared range, namely  $\sim 1200$  nm,  $\sim 1700$  nm, and  $\sim 2300$  nm, would require a separate detector sensitive to these particular regions. Another alternative would be in the near infrared range, i.e. at wavelengths around 930-970 nm, where the peak of absorption for water corresponds to 970 nm and the spectral region around 930 nm corresponds to absorption of lipids [29, 30]. LEDs producing this spectral range are widely available, and in addition detection of intensity is easily realized by means of Si-based CCDs, due to sensitivity curve typically being spread till 1100 nm [31]. Lipids and water have relatively low absorption in the spectral region near 900 – 1000 nm, implying that their detection is increasingly difficult due to simultaneous presence of highly absorbing compounds such as chromophores like melanin and blood. Additionally, skin is characterized by relatively high scattering in this spectral region [32]. Besides, more extensive software will be required due to increasing number of influencing factors and necessity to account for the scattering to separate the effect of the scattering and absorption in the measurement. A potential solution here would be to consider illumination with spatial frequency modulation to measure absorption and scattering separately [33–35], which will allow to calculate concentrations of water and lipids in the tissue and access their balance, and thus, the skin health state along with its appearance simultaneously.

The method that we have developed for skin gloss measurements need to be further improved when used on wider population having inter and intra-individual variations in optical skin properties. The specular reflection components in the image is a physical parameter. The chosen way of detecting specular reflection is a method. For example, using image thresholding to count pixels that may belong to a specular component is an image processing method. However, such a method may be sufficient to analyze a certain image when a human is operating a computer. It may also be sufficient to use if similar images to the image in question are used. The combination to good parametrization as a results from image analytics, the right choice of a data model and data-frame design and study design, the well-definition of the problem in question (classification, regression, clustering, etc.) and employment of train-test strategy allow developing robust detectors that can be generalized for a population to achieve personalization.

We propose to use the wavelength dependent skin reflectance spectra to compensate for the variation in skin optical properties, combination of multiple parameters derived using Image data analytics and possibly analysis of key image features from machine learning backend.

## REFERENCES

- [1] A. Ezerskaia, S. F. Pereira, H. P. Urbach, B. Verhagen, and B. Varghese, *Quantitative and simultaneous non-invasive measurement of skin hydration and sebum levels*, Biomedical Optics Express **7**, 2311 (2016).
- [2] R. R. Anderson, W. Farinelli, and H. Laubach, *Selective photothermolysis of lipid-rich tissue: a free electron laser study*, Lasers in Surgery and Medicine **38**, 913 (2006).
- [3] G. B. Altshuler, R. R. Anderson, and D. Manstein, *Method and apparatus for the selective targeting of lipid-rich tissues*, (2003), US Patent 7,060,061.
- [4] S. L. Jacques, *Optical properties of biological tissues: a review*, Physics in Medicine and Biology **58**, 37 (2013).
- [5] C. P. Fleming, J. Eckert, E. F. Halpern, J. A. Gardecki, and G. J. Tearney, *Depth resolved detection of lipid using spectroscopic optical coherence tomography*, Biomedical optics express **4**, 1269 (2013).
- [6] A. M. Smith, M. C. Mancini, and S. Nie, *Bioimaging: second window for in vivo imaging*, Nature nanotechnology **4**, 710 (2009).
- [7] K. Maruo and Y. Yamada, *Near-infrared noninvasive blood glucose prediction without using multivariate analyses: introduction of imaginary spectra due to scattering change in the skin*, Journal of biomedical optics **20**, 047003 (2015).
- [8] S. L. Jacques and D. J. McAuliffe, *The melanosome: threshold temperature for explosive vaporization and internal absorption coefficient during pulsed laser irradiation*, Photochemistry and Photobiology **53**, 769 (1991).
- [9] E. Alanen, J. Nuutinen, K. Nicklén, T. Lahtinen, and J. Mönkkönen, *Measurement of hydration in the stratum corneum with the moisturemeter and comparison with the corneometer*, Skin research and Technology **10**, 32 (2004).
- [10] G. Yosipovitch, M. Tang, A. Dawn, M. Chen, C. Goh, Y. Chan, and L. Seng, *Study of psychological stress, sebum production and acne vulgaris in adolescents*, Acta Dermato-Venereologica **87**, 135 (2007).
- [11] A. Sbarbati, D. Accorsi, D. Benati, L. Marchetti, G. Orsini, G. Rigotti, and P. Panettiere, *Subcutaneous adipose tissue classification*, Eur J Histochem **54**, e48 (2010).
- [12] F. Silver, J. Freeman, and D. DeVore, *Viscoelastic properties of human skin and processed dermis*, Skin Res Technol **7**, 18 (2001).
- [13] N. Krejci, C. Cuono, R. Langdon, and J. McGuire, *In vitro reconstitution of skin: Fibroblasts facilitate keratinocyte growth and differentiation on acellular reticular dermis*, Journal of Investigative Dermatology **95**, 843 (1991).
- [14] C. R. Harding, *The stratum corneum: structure and function in health and disease*, Dermatologic Therapy **17**, 6 (2004).

- [15] G. K. Menon, G. W. Cleary, and M. E. Lane, *The structure and function of the stratum corneum*, International Journal of Pharmaceutics **435**, 3 (2012).
- [16] D. C. Swartzendruber, P. W. Wertz, D. J. Kitko, K. C. Madison, and D. T. Downing, *Molecular models of the intercellular lipid lamellae in mammalian stratum corneum*, Journal of Investigative Dermatology **92**, 251 (1989).
- [17] N. K. Brogden, L. Mehalick, C. L. Fischer, P. W. Wertz, and K. A. Brogden, *The emerging role of peptides and lipids as antimicrobial epidermal barriers and modulators of local inflammation*, Skin Pharmacol Physiol **25**, 167 (2012).
- [18] A. Watabe, t. Sugawara, K. Kikuchi, K. Yamasaki, S. Sakai, and S. Aiba, *Sweat constitutes several natural moisturizing factors, lactate, urea, sodium, and potassium*, Journal of Dermatological Science **72**, 177 (2013).
- [19] V. R. Wheatley, *The sebaceous glands*, The physiology and pathophysiology of the skin, vol 9, A. Jarrett, ed. (1986).
- [20] P. M. Elias, *Stratum corneum defensive functions: An integrated view*, Journal of General Internal Medicine **20**, 183 (2005).
- [21] A. Krishnaswamy and G. Baranoski, *A biophysically?based spectral model of light interaction with human skin*, Computer graphics forum **23**, 331 (2004).
- [22] E. Berardesca, H. I. Maibach, and K. P. Wilhelm, *Non Invasive Diagnostic Techniques in Clinical Dermatology* (Springer Heidelberg, 2014).
- [23] N. J. Overall, *Confocal raman microscopy: Performance, pitfalls, and best practice*, Applied Spectroscopy **63**, 245A (2009).
- [24] A. Ezerskaia, N. Uzunbajakava, G. Puppels, J. de Sterke, P. Caspers, H. P. Urbach, and B. Varghese, *Potential of short-wave infrared spectroscopy for quantitative depth profiling of stratum corneum lipids and water in dermatology*, Biomedical Optics Express **9**, 2436 (2018).
- [25] P. Kakumanu, S. Makrogiannis, and N. Bourbakis, *A survey of skin-color modeling and detection methods*, Pattern recognition **40**, 1106 (2007).
- [26] M. Darvin, A. Patzelt, S. Gehse, S. Schanzer, C. Benderoth, W. Sterry, and J. Lademann, *Cutaneous concentration of lycopene correlates significantly with the roughness of the skin*, European Journal of Pharmaceutics and Biopharmaceutics **69**, 943 (2008).
- [27] M. A. Gupta and A. K. Gupta, *Dissatisfaction with skin appearance among patients with eating disorders and non-clinical controls*, British journal of dermatology **145**, 110 (2001).
- [28] R. Silvennoinen, K. Peiponen, and K. Myller, *Specular gloss* (Elsevier, 2008).

- [29] P. Taroni, A. Pifferi, A. Torricelli, D. Comelli, and R. Cubeddu, *In vivo absorption and scattering spectroscopy of biological tissues*, Photochemical & Photobiological Sciences **2**, 124 (2004).
- [30] A. N. Bashkatov, E. A. Genina, V. I. Kochubey, and V. V. Tuchin, *Optical properties of human skin, subcutaneous and mucous tissues in the wavelength range from 400 to 2000 nm*, Journal of Physics D: Applied Physics **38**, 2543 (2005).
- [31] H. Huang, L. Liu, and M. O. Ngadi, *Recent developments in hyperspectral imaging for assessment of food quality and safety*, Sensors **14**, 7248 (2014).
- [32] J. G. Fujimoto and D. Farkas, *Biomedical Optical Imaging* (Oxford University press, 2009).
- [33] D. Abookasis, C. Lay, M. Mathews, M. Linskey, R. Frostig, and B. Tromberg, *Imaging cortical absorption, scattering, and hemodynamic response during ischemic stroke using spatially modulated near-infrared illumination*, J. Biomed. Opt. **14**, 024033 (2009).
- [34] J. Weber, D. Cuccia, A. Durkin, and B. Tromberg, *Noncontact imaging of absorption and scattering in layered tissue using spatially modulated structured light*, Journal of Applied Physics **105**, 102028 (2009).
- [35] T. O'Sullivan, A. Cerussi, D. Cuccia, and B. Tromberg, *Diffuse optical imaging using spatially and temporally modulated light*. Journal of Biomedical Optics **17**, 071311 (2012).



# ACKNOWLEDGEMENTS

Firstly I would like to express my gratitude to

**Prof. Hendrik Paul Urbach** for the opportunity to do my Ph.D, for the questions, that made me think carefully regarding the nature of the observed effect, for healthy discussion and always positive attitude even when having a toothache.

**Dr. Silvania Felix Pereira**, thank you support in organizing the flow of the Ph.D work, keeping realistic expectations and focus on the topic of the research, for encouraging and supportive attitude.

**Ms. Yvonne van Aalst**, thank you for support with that not trivial from the first look paperwork, finding right resources in the right time and office to occupy during my visits to TU Delft.

**Ronald Horsten**, without you I still wouldn't know how to solder. What a vital skill when building own LED-based set-up from scratch!

**Dr. Babu Varghese**, I would like to express my gratitude for all the learnings related to industry way of working, for presenting me with opportunities for contentment growth. I really appreciate your attitude of aiming for the best.

**Dr. Natallia Uzunbajakava**, thank you for keeping a cheerful company and helping to bring the Raman paper to a decent level. Thank you for being a colleague and friend, for personal support and fun discussions.

**Dr. Jim Coombs**, thank you for taking me as a part of the team and giving the opportunity to participate in Philips trainings and benefit from well-established facilities.

**Dr. Rieko Verhagen**, I am grateful for your support with timely advise and help with critical aspects of experimental work, It was truly a pleasure to learn from you.

**Dr. Bas Moeskops**, thank you for taking up the challenge of bridging academia and industry in my DfSS GB project mentoring.

**Dr. Frank Verbakel**, I really appreciate your patience in replying on all my questions related to DfSS. Thank you for the great learning.

**Arno Ras**, thank you for your support with all those nuances, doubts and engineering questions and for always cheerful approach.



**Walter Hermans**, thank you for your support with technical details and especially LabView even out of project. I really appreciate your always friendly attitude.

**Dr. Nadya Timofeeva**, thank you for your professional and personal support through my PhD journey and beyond.

**Dr. Mounir Zeitouny**, thank you for your openness and support personal and technical.

**Dr. Jonathan A. Palero**, thank you for those rare, but useful discussion and challenging questions going just to the point.

**Linda Tholen-Beijens**, thank you for supporting me with with medical and personal care devices, and perhaps the most challenging at the moment, ethical assessments and human safety.

5

**Ruth Houbertz**, I am grateful for the very inspirational and encouraging encounter with you during Photonics Europe, that made a right influence in the right moment.

**Dr. Sergei Chivilikhin**, I would like to express my gratitude to you for your limitless patience, brimming energy and teaching in your own free time. Thank you for your effort in putting quantum mechanics and optics in our heads.

**Prof. Viktor Bespalov**, I am very grateful for your professional and personal support in the time when it was really valuable and impactful.

**Dr. Amir Abdolvand**, thank you for your professional and personal support during the last and final stage of this thesis. I have learned a lot from you. I am especially grateful for your encouragement and never compromising quality attitude.

**Marina van Hinsberg (Sorokina)**, my gratitude to you is beyond words. We were together on a long journey from the start of our bachelor to the current moment. You were always there for me: when I was high and when I was low. You always supported me and provided a helping hand and shared happiest moment of my life with me. Thank you for being a sister to me.

**My Mom, Oksana Ezerskaia**, the person who always believed in me, encouraged, the person, who taught me thinking and joy of learning. I am forever indebted for the opportunity to study in the cost of your own comfort. Thank you for encouragement to thrive for excellence, for constant encouragement to walk an extra mile, for teaching me, that there is always an alternative, that any problem can be solved one way or another. Thank you for your wisdom you share with me.

# CURRICULUM VITAE

## **Anna EZERSKAIA**

Anna Ezerskaia was born in Akhtubinsk, Russia on April 23, 1990. She obtained both her Bachelor of Science (B.Sc.) and Master of Science (M.Sc.) degrees in Photonics in 2011 and 2013 from the National Research University of Information Technology Mechanics and Optics, St. Petersburg, Russia. As a part of her Bachelor program she carried out research projects on "Control of the parameters of coherent radiation in the visible and THz frequency range and its use in medicine and telecommunications", "Research methods terahertz optics and spectroscopy for non-invasive diagnosis of pathological processes in biological tissues", "The use of pulsed radiation range from 0.1 to 2 THz for the early diagnosis of atherosclerotic plaques, dermatitis and dental tissue disease" and "Femtotechnologies in biomedicine and engineering terahertz spectral range" at the Femtosecond Laboratory of Biophotonics, Department of Photonics and Optical Information, National Research University of Information Technology Mechanics and Optics, St. Petersburg, Russia. During her Bachelor program she worked as laboratory assistant (2009-2011). As a part of her Master program, she carried out research projects on "Use of ultrashort duration of radiation for biomedical, industrial and secure communications" and "Development of scientific and technical basis of contactless diagnostics of human diseases using terahertz radiation" at the Femtosecond laboratory of Biophotonics, Department of Photonics and Optical Information, National Research University of Information Technology Mechanics and Optics, St. Petersburg, Russia. During her Master program, she worked as project Engineer (2011-2013) at the Femtosecond Laboratory of Biophotonics, Department of Photonics and Optical Information, National Research University of Information Technology Mechanics and Optics, St. Petersburg, Russia.

From June 2014 until June 2018 she performed research towards her Ph.D thesis at the Optics Research Group of the Delft University of Technology, The Netherlands under the supervision of Prof. Dr. H.P. Urbach and Dr. S.F. Pereira and at the Personal Wellness and Care, Philips Research, The Netherlands, under the supervision of Dr. B. Varghese. During her Ph.D research, she developed a new bio-optical technique: Non-invasive differential spectroscopic technique for measuring the skin sebum and water level and method and device for skin gloss non-contact measurement based on low-cost hand-held camera with ring illumination, whose results are presented in this thesis.

## EDUCATION

2014 – 2018	<b>PhD candidate in Bio-Photonics</b> the Delft University of Technology. Philips Research & Delft University of Technology joined project.	The Netherlands
2011 – 2013	<b>M.Sc. in Photonics</b> St. Petersburg National Research Uni- versity of Information Technologies Me- chanics & Optics, St. Petersburg. GPA: 4.9/5.0; Graduation Project with Honor.	Russia
2007 – 2011	<b>B.Sc. in Photonics</b> St. Petersburg National Research Uni- versity of Information Technologies Me- chanics & Optics, St. Petersburg. GPA: 4.8/5.0; Honor, Graduation Project with Honor.	Russia

## WORK EXPERIENCE

2020 – now	<b>Project manager</b> Holland Innovative New transmission electron microscope development for Thermofisher Scientific.	The Netherlands
2018 – 2020	<b>Design engineer</b> ASML Netherlands B.V., Sensors, Light Source group. Designed and constructed a fully auto- mated optical qualification tool with sup- port of electrical and software compe- tences. Contributed to the optical design of one of the light source. Developed and support one of the group competences related to light properties manipulation.	The Netherlands
2014 – 2018	<b>PhD candidate</b> Delft University of Technology, Optics Re- search Group, Delft & Philips Research, Personal care and Wellness, Eindhoven PhD thesis title: “Skin spectroscopy and imaging for cosmetics and dermatology”.	The Netherlands

- 2013 – 2014      **Junior researcher**      Russia  
Center for femtosecond optics and femto-tehnology, the department of Photonics & Optical Information Technology, ITMO University  
Developed and demonstrated 4 methods relying on spectroscopy and photometry for diagnostics of various disorders linked to change of optical properties.
- 2011 – 2013      **Engineer**      Russia  
Center for femtosecond optics and femto-technology, the department of Photonics & Optical Information Technology, ITMO University  
Developed an optical bench for terahertz radiation properties measurement.  
Developed an optical bench for investigation of the interaction of terahertz radiation with tissues of various origin.
- 2009 – 2011      **Research assistant**      Russia  
Research center for femtosecond optics and femto-tehnology, the department of Photonics & Optical Information Technology, ITMO University  
Demonstrated spectral approach in the analysis of pulsed terahertz radiation through analytical description of the pulse diffraction.

## SCHOLARSHIPS AND GRANTS

2018	Travel Grant American Society for Laser Medicine & Surgery, Inc.	USA
2013	Scholarship of the Dmitry Zimin's fund "Dynasty"	Russia
2012	Scholarship of the President	Russia
2012	Scholarship of the Government of the Russian Federation	Russia
2009	Scholarships of Academic Council	Russia

# LIST OF PUBLICATIONS

## PUBLICATIONS

1. **A. Ezerskaia**, N. Uzunbajakava, G. Puppels, J. de Sterke, P. Caspers, H.P. Urbach, B. Varghese, *Potential of short-wave infrared spectroscopy for quantitative depth profiling of stratum corneum lipids and water in dermatology*, [Biomed. Opt. Express](#) **9** (5), 2436-2450 (2018).
2. **A. Ezerskaia**, A. Ras, P. Bloemen, F. Pereira, P. Urbach, B. Varghese, *High sensitivity optical measurement of skin gloss*, [Biomed. Opt. Express](#), **8** (9), 3981-3992 (2017).
3. **A. Ezerskaia**, S.F. Pereira, H.P. Urbach, R. Verhagen, B. Varghese, *Quantitative and simultaneous non-invasive measurement of skin hydration and sebum levels*, [Biomed. Opt. Express](#), **7** (6) 2311-2320 (2016).
4. D. Falcone, M. Peppelman, P. van Erp, **A. Ezerskaya**, B. Varghese, N. Uzunbajakava, *The Role of Quantitative Optical Methods for Personalized Skin Care Solutions: Perspectives Offered by In Vivo Reflectance Confocal Microscopy, Raman Microspectroscopy and Near-infrared Microspectroscopy*, [The cosmetic Chemist](#), 2016.

## PATENT APPLICATIONS

1. Babu Varghese, Harry van Amerongen, Martin Jurna, Jonathan Palero, Martin Jurna, Margaret Horton, Anna Ezerskaya, *A light-based sebum and water level measurement system for skin*, WO2017005628A1
2. Babu Varghese, Marco Baragona, Jonathan Palero, Martin Jurna, Margaret Horton, Anna Ezerskaya, *A skin treatment device*, WO2017097923A1
3. Arno Ras, Water Hermans, Anna Ezerskaya, Babu Varghese, *Skin gloss measurement for quantitative estimation of skin gloss*, 2016PF01342
4. Babu Varghese, Anna Ezerskaya, Arno Ras, Nadya Timofeeva, *Skin gloss measurement which is sensor angle rotation independent*, 2016PF01344
5. Babu Varghese, Wouter Spoorendonk, Walter Hermans, Marco Baragona, Anna Ezerskaya, *Determining a water or lipid level of skin*, 2017PF02638
6. Babu Varghese, Anna Ezerskaya, *Device for use in determining a hydration level of skin*, 2018PF01010
7. Babu Varghese, Anna Ezerskaya, *Device for use in determining an oiliness level of skin*, 2019PF00430

## CONFERENCE PROCEEDINGS

1. A. Ezerskaia, A. Ras, S.F. Pereira, H.P. Urbach, B. Varghese, *High sensitivity spatial and temporal quantification of skin gloss for measuring the desorption kinetics of external agents*, SPIE Photonics Europe, France, Strasbourg, 2018 (Oral paper presentation).
2. A. Ezerskaia, S.F. Pereira, H.P. Urbach, B. Varghese, *Depth profiling of stratum corneum hydration and lipids in vivo: comparison between short-wave infrared spectroscopic and biophysical measurements*, SPIE Photonics Europe, France, Strasbourg, 2018 (Oral paper presentation).
3. A. Ezerskaia, S.F. Pereira, H.P. Urbach, B. Varghese, *High sensitivity optical method for objective assessment of the gloss of human skin*, SPIE Commercial sensing, USA, Orlando, 2018 (Oral paper presentation).
4. A. Ezerskaia, S.F. Pereira, H.P. Urbach, B. Varghese, *Depth resolved quantitative profiling of stratum corneum lipids and water content using short-wave infrared spectroscopy and confocal Raman spectroscopy*, ASLMS annual meeting, USA, Dallas, 2018 (Oral paper presentation).
5. A. Ezerskaia, S.F. Pereira, H.P. Urbach, B. Varghese, *High sensitivity spatial and temporal quantification of skin gloss effect of cosmetics compositions*, ASLMS annual meeting, USA, Dallas, 2018 (Poster paper presentation).
6. A. Ezerskaia, S.F. Pereira, H.P. Urbach, B. Varghese, *Improved sensitivity of short-wave infrared spectroscopic method for depth resolved quantitative profiling of stratum corneum in the low hydration regime*, USA, San Francisco, 2018 (Oral paper presentation).
7. A. Ezerskaia, A. Ras, P. Bloemen, H.P. Urbach, S.F. Pereira, B. Varghese, *Quantitative assessment of skin gloss with high sensitivity in the low gloss regime relevant for physiological skin gloss conditions*, USA, San Francisco, 2018 (Oral paper presentation).
8. A. Ezerskaia, S.F. Pereira, H.P. Urbach, B. Varghese, *Improved sensitivity of short-wave infrared spectroscopic method for depth resolved quantitative profiling of stratum corneum in the low hydration regime*, Annual European Society for Dermatological Research Meeting, Austria, Salzburg, 2017 (poster presentation).
9. A. Ezerskaia, H.P. Urbach, S.F. Pereira, D. Falcone, N. Uzunbajakava, B. Varghese, *Improved sensitivity of infrared spectroscopic method for depth resolved profiling of stratum corneum*, Face2Phase, the Netherlands, Delft, 2017 (poster presentation).
10. A. Ezerskaia, H.P. Urbach, S.F. Pereira, B. Varghese, *Quantitative and simultaneous non-invasive SWIR spectroscopic measurement of skin hydration and sebum levels*, Photonics Event, the Netherlands, Veldhoven, 2017 (poster presentation).
11. A. Ezerskaia, S.F. Pereira, H.P. Urbach, B. Varghese, *Quantification of changes in skin hydration and sebum after tape stripping using infrared spectroscopy*, Photonics West, BiOS: Photonics in Dermatology and Plastic Surgery, 1003702, San-Francisco, USA, 2017 (Oral paper presentation).

12. A. Ezerskaia, S.F. Pereira, H.P. Urbach, B. Varghese, *Infrared spectroscopic measurement of skin hydration and sebum levels and comparison to corneometer and sebumeter*, Proc. SPIE 9887, Biophotonics: Photonic Solutions for Better Health Care V, 98872G, Brussels, Belgium, 2016 (Oral paper presentation).
13. A. Ezerskaia, S.F. Pereira, H.P. Urbach, B. Varghese, *Inter- and intra-individual differences in skin hydration and surface lipids measured with mid-infrared spectroscopy*, Proc. SPIE 9715, Optical Diagnostics and Sensing XVI: Toward Point-of-Care Diagnostics, 97151G, San-Francisco, USA, 2016 (poster presentation).
14. A. Ezerskaia, S.F. Pereira, H.P. Urbach, B. Varghese, *Quantitative and simultaneous non-invasive infrared spectroscopic measurement of skin hydration and sebum levels*, International Society for Biophysics and Imaging of the skin, ISBS, Lisbon, Portugal, 2016 (Oral paper presentation).
15. A. Ezerskaia, S.F. Pereira, H.P. Urbach, B. Varghese, *Quantitative and simultaneous non-invasive in-vivo measurement of skin hydration and sebum levels*, Biophotonics and Imaging Graduate Summer School, Galway, Ireland, 2016 (poster presentation).
16. A. Ezerskaia, S.F. Pereira, H.P. Urbach, B. Varghese, *Non-contact Infrared Spectroscopic measurement of skin hydration and sebum levels and comparison to biophysical methods*, Micro Photonics, Berlin, Germany, 2016 (Oral paper presentation).
17. A. Ezerskaia, S.F. Pereira, H.P. Urbach, B. Varghese, *Quantitative and simultaneous non-invasive in-vivo measurement of skin hydration and sebum levels*, SPIE Photonics West Europe, 7 February, 2016 (Oral paper presentation).

## OTHER PUBLICATIONS OF THE AUTHOR

1. O. Smolyanskaya, A. Ezerskaya, I. Prozheev, E. Strepitov, *Terahertz reflectance spectra of skin dermatitis and morphological changes*, [Scientific and Technical Journal St. Petersburg National Research University of Information Technologies, Mechanics and Optics](#), **13** (3), 108-112 (2013).
2. A. Ezerskaya, M. Tsurkan, O. Smolyanskaya, N. Balbekin, I. Romanov, I. Prozheev, E. Strepitov, I. Prosanov, *Amino acids identification in the human skin by spectra application of 0,05-1,2 THz range*, [Scientific and Technical Journal St. Petersburg National Research University of Information Technologies, Mechanics and Optics](#), **13** (2), 50-54 (2013).
3. A. Ezerskaya, O. Smolyanskaya, A. Goncharenko, I. Geyko, *Study of the possibility of diagnostic cataract in the THz range*, [Ophthalmic Technologies XXIII](#), edited by Fabrice Manns, Per G. Söderberg, Arthur Ho, [Proc. of SPIE](#), 8567, 85671U (2013).



4. A. Zabolotny, S. Sakhnov, S. Parahuda, O. Smolyanskaya, A. Ezerskaya, I. Geyko, *On the interaction of terahertz radiation with ocular surface - the fibrous covering of the eyeball, cornea and sclera, in the experiment*, Journal of the Orenburg State University, **12**, 50-54 (2012).
5. A. Ezerskaya, D. Ivanov, S. Kozlov, Y. Kivshar, *Spectral approach in the analysis of pulsed terahertz radiation*, Journal of Infrared, Millimeter, and Terahertz Waves, 2012, **33** (9), 926-942 (2012).
6. A. Ezerskaya, O. Smolyanskaya, S. Parahuda, Y. Grachev, A. Goncharenko, *The terahertz transmission and reflection spectra of cataract modified human crystalline lense*, Scientific and Technical Journal St. Petersburg State University of Information Technologies, Mechanics and Optics, **12** (2), 92-96 (2012).
7. A. Ezerskaya, I. Romanov, O. Smolyanskaya, Y. Grachev, *Early caries diagnosis of teeth hard tissue by terahertz range laser radiation*, Scientific and Technical Journal, St. Petersburg State University of Information Technologies, Mechanics and Optics, **11** (6), 92-97 (2011).
8. A. Ezerskaya, D. Ivanov, V. Bepalov, S. Kozlov, *The diffraction of one-period terahertz electromagnetic waves*, Journal of Optical Technology, **78** (8), 109-117 (2011).
9. A. Ezerskaya, D. Ivanov, V. Bepalov, S. Kozlov, *The diffraction of one-period terahertz electromagnetic waves with a Gaussian transverse distribution*, Scientific and Technical Journal St. Petersburg State University of Information Technologies, Mechanics and Optics, **11** (1), 3-7 (2011).
10. A. Ezerskaia, E. Strepitov, I. Prozheev, O. Smolyanskaya, *Research on Possibilities of Abnormal Tissues Diagnostic by THz Reflection Spectra*, International Forum Progress In Electromagnetics Research Symposium PIERS, Stockholm, Sweden, August 12-15, 2013 (Poster presentation).
11. A. Ezerskaia, I. Prozheev, E. Strepitov, O. Smolyanskaya, *Databank of main biomolecules, skin layers and cell cultures*, International Symposium Fundamentals of LASER Assisted Micro- & Nanotechnologies FLAMN-13, Saint Petersburg, Russia, June 24-28, 2013 (Poster presentation).
12. A. Ezerskaia, E. Strepitov, I. Progeev, O. Smolyanskaya, *Application terahertz spectroscopy for early diagnosis pathological processes in biological tissues*, International Conference on Coherent and Nonlinear Optics (ICONO 2013) International Conference on Lasers, Applications, and Technologies (LAT 2013), Moscow, Russia, June 18-22, 2013 (Poster presentation).
13. O. Smolyanskaya, A. Ezerskaia, M. Tsurkan, *The terahertz spectroscopy application for the early diagnosis of pathological processes in biological tissues*, VII International Conference Fundamental Problems of Optics - FPO – 2012, St. Petersburg, Russia, October, 15-19, 2012 (Oral paper presentation).
14. I. Prozheev, A. Ezerskaia, *Identification of main molecules that contain in the skin and connective tissue using reflection spectra*, VII International Conference Fundamental Problems of Optics - FPO – 2012, St. Petersburg, Russia, October 15-19, 2012 (poster presentation).

15. A. Ezerskaia, I. Prozheev, E. Strepitov, I. Romanov, O. Smolyanskaya, *Research the characteristics of the THz spectra reflect the modified human tissue*, VII International Conference Fundamental Problems of Optics - FPO – 2012, St. Petersburg, Russia, October 15-19, 2012 (Oral paper presentation).
16. A. Ezerskaia, O. Smolyanskaya, S. Goncharenko, I. Romanov, *THz transmission and reflection spectra of human abnormal lens, hard dental tissues and skin*, IV Congress of Russian biophysicists, Nizhniy Novgorod, Russia, August 20-26, 2012, V III, 81. (Oral paper presentation).
17. A. Ezerskaia, E. Strepitov, I. Prozheev, O. Smolyanskaya, *Research of specific peculiarities of THz reflection spectra of abnormal human tissues*, The 15th International Conference Laser Optics 2012, June 25-29, 2012 (Poster presentation).
18. A. Ezerskaia, S. Parahuda, A. Goncharenko, Y. Grachev, O. Smolyanskaya, S. Kozlov, *Investigation of the possibility of diagnostic cataract lenses of human?s eyes in the THz range*, the Joint Student Session at the 2-d International Conference Terahertz and Microwave Radiation: Generation, Detection and Application, Moscow, Russia, July 20-22, 2012 (Oral paper presentation).
19. A. Ezerskaia, S. Parahuda, A. Goncharenko, Y. Grachev, O. Smolyanskaya, S. Kozlov, *Investigation of the possibility of diagnostic cataract lenses of human?s eyes in the THz range*, The 2-nd International Conference Terahertz and Microwave radiation: Generation, Detection and Applications, Moscow, Russia, June 20-22, 2012 (Poster presentation).
20. A. Ezerskaia, O. Smolyanskaya, I. Romanov, S. Parahuda, Y. Grachev, S. Goncharenko, *THz transmission and reflection spectra of human abnormal lens and hard dental tissues*, Russian Conference on Information Optics and Photonics: Proceedings. Moscow. MEPhI, Russia, 25-27 January 2012 (Oral paper presentation).
21. I. Romanov, A. Ezerskaia, Y. Grachev, O. Smolyanskaya, *Definition diffuse and collimated human hard dental tissues components by terahertz photometry method*, VII International Conference of Young Scientists and Specialists "Optics - 2011", St. Petersburg, Russia, 17-21 October 2011 (Poster presentation).
22. S. Parahuda, A. Goncharenko, A. Ezerskaia, Y. Grachev, O. Smolyanskaya, *Study the characteristics of the transmission and reflection cataract modified lens human eye spectra*, VII International Conference of Young Scientists and Specialists "Optics - 2011", St. Petersburg, Russia, 17-21 October 2011 (Poster presentation).
23. A. Ezerskaia, D. Ivanov, S. Kozlov, *The diffraction of one period terahertz electromagnetic waves*, The 8th International Workshop "Strong Microwaves and Terahertz Waves: Sources and Applications", N. Novgorod, Russia, 9-16 July, 2011 (Poster presentation).
24. D. Ivanov, A. Ezerskaia, S. Kozlov, *The diffraction of single cycle terahertz waves*, International conference "Days on Diffraction - 2011" Saint Petersburg, May 30 - June 3, 2011 (Poster presentation).

25. A. Ezerskaia, *Diffraction one-period terahertz electromagnetic waves*, Conference of Young Scientists, Issue 2 - St. Petersburg: St. Petersburg State University Mechanics and Optics, 2011 (Poster presentation).
26. A. Ezerskaia, D. Ivanov, S. Kozlov, *Self-influence terahertz waves from a single vibration in its focus in the optical medium*, VI International Optical Congress "Optics - XXI century" VI International Conference "Fundamental Problems of Optics" "FPO - 2010" St. - Petersburg, Russia, 18-22 October, 2010 (Poster presentation).
27. D. Ivanov, A. Ezerskaia, *Features nonparaxial diffraction of terahertz waves from one complete fluctuations*, VI International Optical Congress "Optics - XXI century" VI International Conference "Fundamental Problems of Optics" "FPO - 2010" St. - Petersburg, Russia, 18-22 October 2010 (Oral paper presentation).
28. D. Ivanov, A. Ezerskaia, *The features of one oscillation terahertz pulse diffraction on the slit*, International Conference Fundamentals of laser Assisted Micro- & Nanotechnologies (FLAMN – 10), St. Peterburg – Pushkin, Russia, July 5-8, 2010 (Poster presentation).
29. A. Ezerskaia, D. Ivanov, *Features self-focusing of light waves of a few oscillations with transverse dimensions much larger than the longitudinal ones*, VI International Conference of Young Scientists and Specialists "Optics - 2009", St. Petersburg, Russia, 19-23 October 2009 (Poster presentation).